



TORONTO  
2015

**YOUR MOMENT IS HERE**

PAN AMERICAN AND PARAPAN AMERICAN GAMES

# TORONTO 2015

YOUR MOMENT IS HERE



TORONTO  
2015

PAN AMERICAN AND PARAPAN AMERICAN GAMES

Michael Chambers  
President/président

Chris Rudge  
Chief Executive Officer and Secretary General/  
Chef de la direction et secrétaire général



*for the fire within  
animés par le feu sacré*

25 March 2009

Mario Vázquez Raña  
President  
Pan American Sports Organization

Dear President Vázquez Raña:

On behalf of the Canadian Olympic Committee and the Olympic Movement in Canada, it is my honour and privilege to present to you the Bid by the City of Toronto to host the 2015 Pan American Games.

The Canadian Olympic Committee has been a full and engaged partner in the Bid from its inception and wholeheartedly supports it. Our support is based on having satisfied ourselves that the Toronto Bid is committed to, and will deliver if successful, an athlete centred Games, an exceptional and technically knowledgeable Games organization, a sustainable Games legacy that not only benefits Canadian sport but is available to countries within the Pan American family, and a truly unique and positive experience for the athletes, coaches, officials, and spectators that builds and promotes the Pan American brand and is wholly in tune with the Olympic ideals that guide the Pan American Games.

Canada has a history of staging successful Major Games and international sporting events including, notably, the hosting twice in Winnipeg, Manitoba, in 1967 and in 1999, of a Pan American Games. Toronto is ready to continue that tradition. Toronto is a modern, cosmopolitan, multi-cultural, multi-faceted city. Sport is very much a part of its culture as it is of the Province of Ontario in which it is situated, and indeed as it is of the whole of Canada. The Canadian Olympic Committee would be honoured if Toronto, Ontario, were chosen to host the 2015 Pan American Games and we, through these Games, were again allowed the opportunity to serve the Olympic Movement in the Americas and Caribbean, and to further strengthen our bonds with our Pan American Family.

Thank you for your consideration.

Sincerely,



Michael Chambers  
President, Canadian Olympic Committee  
Third Vice President, Pan American Sports Organization

21 St. Clair Ave. E., Suite 900, Toronto, ON, Canada M4T 1L9  
Ph (416) 962-0262, Fax (416) 967-4902, [www.olympic.ca](http://www.olympic.ca)



PRIME MINISTER • PREMIER MINISTRE

April 6, 2009

Mr. Mario Vázquez Raña  
President  
Pan American Sport Organization  
Calle Gomez Farias No. 51  
Colonia San Rafael  
06470 Mexico D.F.  
Mexico

Dear President Vázquez Raña:

On behalf of the Government of Canada, I am pleased to confirm our Government's support for the Toronto 2015 Pan Am and Parapan Am Games bid.

Canada is committed to sporting excellence and has been a proud participant and successful host of past Pan Am Games. Furthermore, hosting the 2015 Pan Am Games is in line with the Government's renewed Americas-focused strategy and will help strengthen our ties by showcasing what Canada has to offer to our friends throughout the Caribbean and the Americas.

The Government of Canada regards hosting the 2015 Pan American and Parapan American Games in Toronto as a matter of pride to Canadians. In partnership with the Government of Ontario, we have committed \$500 million towards the costs to host the Games, which will be used to expand existing infrastructure and ensure a successful Games in 2015. Investing in the Pan Am and Parapan Am Games will create a legacy of new and improved athletic facilities in the Greater Toronto Area that will last long after the Games are completed.

Canada has a superb record in mounting international events. Canadians know how to host the world and how to put on a great show. We feel Toronto will continue this fine tradition in 2015 and we look forward to the endorsement of the Pan American Sports Organization to take on this important responsibility.

Yours sincerely,

The Rt. Hon. Stephen Harper, P.C., M.P.  
Prime Minister of Canada

The Premier  
of Ontario

Legislative Building  
Queen's Park  
Toronto, Ontario  
M7A 1A1

Le Premier ministre  
de l'Ontario

Édifice de l'Assemblée législative  
Queen's Park  
Toronto (Ontario)  
M7A 1A1



March 26, 2009

Mr. Mario Vázquez Raña  
President  
Pan American Sports Organization  
Calle Gómez Farías No. 51  
Colonia San Rafael  
06470 Mexico D.F.  
Mexico

Dear President Vázquez Raña:

I am delighted to express the Province of Ontario's wholehearted support for the City of Toronto in its bid to host the 2015 Pan American and Parapan American Games. I would also like to reaffirm my strong personal commitment to making the games an unparalleled competitive experience for athletes from the PASO family.

Located in the heart of Canada, Toronto — Ontario's capital — is home to people and cultures from around the globe. It is also a metropolis that reflects the vibrancy and dynamism of the Americas and the Caribbean. Virtually every PASO nation is represented in Toronto, making it one of the world's most cosmopolitan cities.

As our submission makes clear, the Government of Ontario is fully committed to the bid. I believe that Toronto's hosting of the games would create enduring legacies and enhance our province for decades to come. The sport venues and facilities that would be developed in anticipation of the 2015 Games would not only provide a richer sports environment for our athletes, but also a richer recreational life for all Ontarians.

We are joined and supported in our bid by the Government of Canada, our partner in funding the construction of sport venues and facilities. The Government of Ontario confirms its commitment to the Pan American and Parapan American Games by providing the financial guarantee in keeping with the requirements of the Pan American Sports Organization.

As Premier, I speak for all Ontarians when I say it would be our province's great honour and privilege to host the 2015 Pan American and Parapan American Games. We look forward to welcoming the Americas and the Caribbean to Toronto in 2015.

Please accept my personal best wishes.

Yours truly,

A handwritten signature in blue ink, appearing to read "Dalton McGuinty".

Dalton McGuinty  
Premier of Ontario



*Mayor*

# DAVID MILLER

March 26, 2009

Mario Vázquez Raña  
President  
Pan American Sports Organization

Dear President Vázquez Raña:

Toronto stands ready to host an outstanding 2015 Pan American Games and Parapan American Games.

As outlined in our bid, the City of Toronto has all of the practical assets needed to make the 2015 Games a success, including world-class sporting venues and cultural festivals; top notch accommodations and a highly trained hospitality sector; an efficient transportation network linking all parts of the city and region; a distinguished track record hosting international events; and a well deserved reputation for being a safe, accessible and dynamic destination for visitors.

But Toronto has something further to offer that cannot be found anywhere else, at least not nearly to the same degree. Whenever an international sporting event is held in Toronto, the windows of homes and cars around the city light up with the colours of the national flags of every country participating in the competition. For the duration of the event, Toronto's diversity and the commitment of its residents to the ideals of global citizenship are on full display.

I am confident that Toronto's unique international character will make it a perfect host for the 2015 Pan American Games and Parapan American Games, and that all athletes, coaches, team officials and visitors will feel comfortable and welcome in our city.

The City of Toronto will continue to work in close partnership with the Canadian Olympic Committee, the Province of Ontario, the Government of Canada, and various municipalities, universities and partners to ensure that the 2015 Games comply with all of the Pan American Sports Organization's (PASO) statutes and regulations.

Finally, I would also like to underscore my personal support for this bid, the work that PASO does, and the Games themselves. As the mayor of Toronto, I see both the practical value – and the intangible values – that the Pan American and Parapan American Games will bring to our city and region. A successful bid will leave a rich cultural and sporting legacy in neighbourhoods across the city and in communities around the Toronto region. Of equal importance, it will provide all of the Games' participants with an opportunity to celebrate the diversity of talent, achievement, culture and language that make Toronto, Ontario and Canada – and indeed all PASO member nations – so special.

Toronto looks forward to welcoming the 2015 Pan American and Parapan American Games.

Yours truly,  
  
Mayor David Miller  
City of Toronto



City Hall • 100 Queen Street West • 2nd Floor • Toronto, Ontario M5H 2N2  
Telephone: 416-397-CITY • Fax: 416-696-3687 • E-mail: mayor\_miller@toronto.ca

# THE TORONTO ADVANTAGE

The plan for the Toronto 2015 Pan American Games has been built with two goals in mind, both designed to create greater opportunities for success for the Pan American Games movement and for the athletes, coaches, officials and National Olympic Committees (NOCs) that constitute it.

The first goal is to capitalize on the excellent work of PASO - particularly with its Commission of Olympic Solidarity - and of individual PASO NOC's in order to enhance and create opportunities for the success of athletes, coaches, national teams and NOC programs of all sizes. The second goal is to continue to build the scale, prestige and brand of the Pan American Games, entrenching and elevating the Games' status as one of the most important sport properties worldwide.

## CONTINUING TO BUILD THE BRAND AND INFLUENCE OF THE PAN AMERICAN GAMES

### 1. GUARANTEED FINANCIAL COMMITMENT

All levels of government - federal, provincial and municipal - are solidly behind Toronto 2015. The Province of Ontario, Canada's most populous province, is the Games' deficit guarantor. This is secure support from stable government sources which ensures that we can execute the 2015 Games with an optimal blend of reliability and ambition.

### 2. REVENUE-DRIVING MARKET

Toronto is Canada's financial capital, the third-largest financial market in North America and home to a regional population of 8.1 million people. It is also an easy drive from the United States and one of the most active media markets in the world. All of this defines a market that is rich with opportunities for sponsorship, private sector partnerships and revenue generation.

### 3. MEDIA HUB

Toronto is a true global media capital with six major daily newspapers, four general all-sports television networks, multiple specialty sport networks and one of the first all-sports radio stations in the world. The intensity of the Toronto media market ensures that the vehicles, technology and talent will be available to bring the stories of the 2015 Pan American Games to more people in more ways in more parts of the world.

### 4. BROADCAST OF 2011 AND 2015

Toronto 2015 will work with Guadalajara 2011 to arrange for up to 50 hours of coverage from the 2011 Games to be broadcast in Canada to build excitement for the Pan American Games and leverage sponsorships, partnerships and ticket sales for 2015. For the Toronto 2015 Games, the Games broadcast commitment will be more than 300 hours of coverage in English, French and Spanish, and to full adoption of the latest web-based and mobile media strategies.

### 5. TRANSFER-OF-KNOWLEDGE AND INFORMATION PROGRAM

Toronto 2015 will be an active partner with both the Canadian and PASO sport communities to contribute to the on-going development of resources available to communities and countries that plan to bid for and host major sport events. Toronto 2015 will offer one-on-one assistance to future hosts for both Pan American and regional games, as well as provide seminars and written materials on bidding and hosting best practices.

### 6. GAMES HOSTING INTERNSHIPS

Individuals from future host organizing committees throughout PASO will have the opportunity to work in staff positions across multiple disciplines with the Toronto 2015 Host Organizing Committee during the preparations for the 2015 Games. The internships could begin as early as 2012.

### 7. VOLUNTEER RECRUITMENT

The anticipated 19,000 Games volunteers required for Toronto 2015 will include volunteers recruited from diverse communities, with these volunteers participating in an innovative and comprehensive training program that will prepare volunteers for the Games and develop transferable skills. The volunteer management modules developed for the 2015 Pan American Games will become part of a web-based service available to sport organizations throughout the PASO community.



## CREATING NEW OPPORTUNITIES FOR ATHLETES AND NOC'S

### 1. ATHLETE SCHOLARSHIPS

The Toronto 2015 Athlete Scholarship Program will give high performance athletes in a variety of sports the chance to live and train in Canada with Canadian athletes for up to 18 "athlete months" in the years leading up to the 2015 Games. Each NOC will be able to send one athlete to Toronto for 18 months, or 18 athletes for one month each, or any combination in between.

### 2. COACHING SEMINARS AND CLINICS

Toronto 2015 will host three regional coaching conferences per year in Pan American countries from 2011 to 2014, covering on-site costs (accommodation, meals and workshop fees) for coaches selected by PASO NOC's. The Coaching Association of Canada will also host the International Council for Coach Education continental coaching conference for the Americas in Toronto in 2014.

### 3. SPORT ADMINISTRATION AND MARKETING WORKSHOPS

Toronto 2015 will host in Pan American countries three regional sport management workshops per year from 2011 to 2014 for PASO NOC's. Topics will include sport marketing, grant application writing, communications, media relations and event planning. Toronto 2015 will cover on-site costs for PASO participants.

### 4. TRAVEL SUPPORT GRANT

Toronto 2015 will provide a travel support grant for the Games that will provide real budget relief and allow NOC's to invest their resources in their teams and athletes instead of airfare.

### 5. ORGANIZATIONAL EXCELLENCE AND EXPERIENCE

Toronto and its surrounding region are experienced hosts of a variety of international sport events. At Games time, the experience and expertise of the Toronto 2015 team, combined with the experience and talent of the veterans of the Vancouver 2010 Olympic Winter Games, will ensure that athletes only need to concentrate on performance. Toronto 2015 will handle everything else.

### 6. IDEAL COMPETITIVE CONDITIONS

Athletes can expect to compete in a clean and healthy climate ideally suited for performance. A Toronto Games in July means long, warm, sunny days and comfortable evenings with an average daytime temperature of 26° C at a competition-ideal altitude of 112 metres above sea level. The new Pan American Village and every sport venue will be world-class, meeting or exceeding their respective International Olympic Committee or International Sport Federation requirements.

### 7. WELCOMING, SAFE COMMUNITIES

Toronto is famous among global visitors for its safety and cleanliness. The Mercer survey points to Toronto as the "best" city for personal safety in the Western Hemisphere and *The Economist* magazine ranked Toronto the fifth "most livable" city in the world.

### 8. YOUR HOMETOWN IN CANADA

Every athlete dreams of competing in front of a hometown crowd. That will happen in Toronto ... for everyone. Toronto is home to people from every PASO country. Those communities are ready to welcome and cheer all Pan American teams. Every athlete who comes to the Games will have a built-in cheering section from his or her own country and culture.

### 9. DEDICATED CARS AND DRIVERS

The convenience of the NOC's is a paramount concern for Toronto 2015, so in addition to the standard allocation of dedicated cars and drivers to the people holding key leadership positions within PASO, the IOC and the International Sport Federations, Toronto 2015 will provide every NOC with a dedicated car and driver for each of the NOC President and the Secretary General regardless of team size.

### 10. ENHANCED RATE CARD

Toronto 2015 will provide PASO and all NOC's with an "enhanced" rate card system that offers them the best rates and greatest convenience in obtaining the services and resources they might require in Toronto.

THE TORONTO ADVANTAGE



# CONTENTS

<b>EXECUTIVE OVERVIEW:</b>	Our Vision and Motivation	1
<b>SECTION 1:</b>	Candidate City	9
<b>SECTION 2:</b>	Domestic Conditions	19
<b>SECTION 3:</b>	Immigration and Customs	25
<b>SECTION 4:</b>	Climate and the Environment	31
<b>SECTION 5:</b>	Security	37
<b>SECTION 6:</b>	Medical Services	43
<b>SECTION 7:</b>	Pan American Village	49
<b>SECTION 8:</b>	Accommodations	65
<b>SECTION 9:</b>	Transportation	71
<b>SECTION 10:</b>	Sport Program	79
<b>SECTION 11:</b>	Venues	85
<b>SECTION 12:</b>	Ceremonies, Culture and Innovation	163
<b>SECTION 13:</b>	Media Facilities and Services	171
<b>SECTION 14:</b>	Telecommunications and Technology	177
<b>SECTION 15:</b>	Finance	183
<b>SECTION 16:</b>	Legal Affairs	189
<b>SECTION 17:</b>	Marketing	193
<b>SECTION 18:</b>	Legacy	199
<b>SECTION 19:</b>	Parapan American Games	207



# PASSION. EXCITEMENT. TRIUMPH.

Every athlete dreams of this moment. Competing in world class venues and a world class setting. Striving to be the best. New friends, new experiences. Memories that will last a lifetime. A host country stands riveted, a hemisphere entranced.

## YOUR MOMENT IS HERE

This, and so much more, is our vision of Toronto 2015.

# OUR VISION AND MOTIVATION

## TORONTO 2015: THE PROMISE OF EXCELLENCE

The Toronto 2015 Pan American Games are more than just an event or competition – they are a promise. For Toronto 2015, this is a promise to all our friends in the Pan American Sports Organization (PASO) that we are committed to ensuring that the Toronto 2015 Games experience is unparalleled. From the moment you begin arranging your travel, to your first steps off the airplane in Toronto, to the time when your flight home takes to the air, the Toronto 2015 team is committed to providing superior service, hospitality and convenience. Our focus is on ensuring that all athletes have the best possible opportunity to excel in, and enjoy, the 2015 Pan American Games.

The best way for us to meet this goal is to allow all athletes to focus on the “margin of victory” – the difference that puts competitors on the podium, the difference that makes Pan American champions. That difference should be talent, dedication, preparation and inspiration. It should be discipline, coaching and sacrifice. But in the world of multi-sport games, the margin of victory can often depend on other things, like whether or not a competitor has a comfortable night’s sleep, familiar food, supportive crowds or a simple trip from the Pan American Village to the sport venue.

The margin of victory should live in the competition of athlete against athlete, not in the logistics, conditions and circumstances of the Games. Those aspects of the Games, those behind-the-scenes elements, can be the difference between disappointment and achievement, between frustration and the podium, between a setback and a stepping stone.

The Toronto 2015 Pan American Games will ensure that the margin of victory – the margin of excellence – is exactly where it should be – in the performance of your athletes. The Toronto 2015 Team will take care of all the details so your athletes can take care of the competition.

## YOUR ATHLETES

Our first goal in hosting the Pan American Games is to help all athletes achieve their competitive goals and to help them to meet and exceed the standards set. The Toronto 2015 Pan American Games will be about the athletes. Our goal is to get your team to the Games more affordably, comfortably and efficiently by offering the most direct travel options, an enhanced travel grant and expedited accreditation. Our goal is to minimize bureaucracy while maximizing safety, security, convenience and comfort. Our goal is to meet athletes’ needs and anticipate their preferences. We will also help prepare them for success by inviting them to train in Canada with Canadian athletes for up to 18 months in the years leading up to the 2015 Games. Our goal is to ensure that athletes are able to focus on two things while they are in Toronto: competing to the best of their abilities, and enjoying their Pan American experience.

## YOUR COACHES AND TEAM OFFICIALS

Your coaches and team officials are as much a part of the Toronto 2015 plans as your athletes. Every coach and official will have the benefits of the same enhanced travel, accreditation and customs/immigration processes as the athletes, processes designed for the greatest convenience and ease. In Toronto, your coaches and team officials will enjoy the comfort of the user-friendly Pan American Village, with all the conveniences, amenities and security of a high performance games village. Before the Games, we will offer innovative programs designed to help prepare your coaches and teams for success. During the Games, we will enhance the access coaches and officials have to the equipment, facilities and expertise that will maximize their ability to help your athletes excel. We understand that even in individual sports, victory is a team achievement.

## YOUR NATIONAL OLYMPIC COMMITTEE

The approach Toronto 2015 takes to ensuring that your athletes compete under optimal conditions and with their attention on performance is the same approach we will take to ensuring that all 42 Pan American National Olympic Committees (NOC) are part of a sport environment that gives them the ability to achieve their goals for the 2015 Pan American Games. In the years before 2015, our administrative processes and practices will be tested and perfected at the Vancouver 2010 Olympic Winter Games and other high-profile international events across Canada so that everything from accreditation to travel will be as efficient, cost effective and user-friendly as possible. In the pre-Games period we will invite you to Toronto to see the Pan American Village, to train and compete in the Games venues; we will help prepare you for success. Our international Games legacy will focus on the years before 2015, when our support of your preparations can help turn an average performance into a personal best, a final into a podium finish or a bronze medal into gold.

## YOUR PAN AMERICAN SPORTS ORGANIZATION

The same way Toronto 2015 supports the goals of individual athletes, support staff and NOC's, we will support the mission and vision of PASO. With the market size, financial base, media infrastructure and strategic capacity to attract resources, sell tickets, involve sponsors and extend the broadcast and media reach of the Games, Toronto 2015 will build the brand, profile and reach of PASO and the Pan American Games with a strategy that incorporates more than just the 2015 Games. Toronto 2015 has an innovative broadcast and media strategy that will help extend the reach of the 2011 Guadalajara Games, setting the stage for 2015 and beyond.

## OUR MOTIVATION

Toronto 2015 is focused on serving the needs of your team, your NOC and PASO, but we also have a great deal to gain from the privilege of hosting the Games. Everything from our sport infrastructure to our economy, and from our youth to our high performance athletes will benefit from the 2015 Pan American Games. Toronto, for all of its assets and advantages, has a number of distinct needs and opportunities that the 2015 Pan American Games will address.

While the city already has a number of world-class professional sport venues ready to play key roles in 2015, Toronto and its surrounding area face significant infrastructure needs for amateur sport and training. In Canada's most populous region, meeting the needs of our country's greatest concentration of high performance and recreational athletes requires a significant investment in training and competition venues. The Pan American Games will help address that need. They will energize programs that support physical activity and healthy living, they will inspire our children and youth, and they will create local heroes. The Games will also open the door for more young Canadians to pursue their Pan American and Olympic dreams by putting facilities, coaching, sport science and an intensified competitive culture on the doorsteps of more future champions and record holders.

Toronto already has in place a number of economic, environmental, social and service strategies that align perfectly with hosting an event the size, scope and profile of the Pan American Games. The Pan American Games will leverage and magnify investments in everything from economic opportunity to public transportation, and from environmental remediation to affordable housing.

The Games will help redefine and invigorate the City of Toronto, the Toronto region and the Province of Ontario.

## THE TORONTO ADVANTAGE

### Creating New Opportunities for Athletes and NOC's

The conditions, experience, talent pool and market area of Toronto and its surrounding region, along with the Toronto 2015 international pre-Games legacy plan, will provide a springboard for all PASO NOC's and their athletes to achieve new levels of Games preparedness and competitive excellence.

#### 1. Athlete Scholarships

The Toronto 2015 PASO Athlete Scholarship Program will provide funding to support high performance athletes in a variety of sports from Pan American nations to live and train in Canada with Canadian athletes in the years leading up to the 2015 Pan American Games. The scholarships will include access to appropriate training facilities and a full-time coach, room and board, medical and sport science assistance, accident and illness insurance, a basic allowance and return economy airfare from their home countries to Canada.

Toronto 2015 will make funds available for the PASO Athlete Scholarship Program from 2012 through to 2015. The program will provide scholarship funding for each NOC within PASO for up to 18 "athlete months." This means that each NOC could send one athlete to Canada to train for 18 months, or 18 athletes for one month each, or any combination in between.

#### 2. Coaching Seminars and Clinics

Toronto 2015 will organize and host three regional conferences per year from 2011 to 2014, and will cover all on-site costs (accommodation, meals and workshop fees) for coaches selected by PASO NOC's to help offset the cost of their coaches' participation. Toronto 2015 will fund Canadian high performance coaches and sport experts to travel to Pan American nations to conduct these sessions.

Toronto 2015 will partner with the Coaching Association of Canada (CAC) for the provision of this program. The CAC has assisted a num-

ber of countries around the world in establishing coaching development systems based on Canada's National Coaching Certification Program (NCCP). With the assistance of Toronto 2015, the CAC will also play host to the International Council for Coach Education (ICCE) continental coaching conference for the Americas in Toronto in 2014, the year before the Toronto Games.

### 3. Sport Administration and Marketing Workshops

Toronto 2015 will host in Pan American countries three regional sport management workshops per year from 2011 to 2014 for PASO NOC's. Topics will include sport marketing, grant application writing, communications, media relations and event planning. Toronto 2015 will cover on-site costs for PASO participants including accommodation, meals and workshop fees. Sport management professionals from Canada and elsewhere will facilitate sessions on a full range of topics important to NOC's and amateur sport.

### 4. Travel Support Grant and Transportation

It is easy and convenient to get to Toronto. Thirty PASO countries have direct flights to and from Toronto's modern Lester B. Pearson International Airport, ensuring that your teams and athletes will arrive with a minimum of delay and the greatest of convenience. Teams from every PASO country will have travel options available that provide either convenient direct flights to Toronto or connecting flights through their preferred transfer location to ensure convenience at every step of the journey.

Upon arrival in Canada, a tested and streamlined immigration and customs service will move all athletes, coaches and officials swiftly through the airport and then to the Pan American Village or host accommodations.

Toronto 2015 is also providing a travel support grant that will give NOC's real budget relief and allow increased investment in teams and preparation instead of airfare.

### 5. Organizational Excellence and Experience

Toronto and its surrounding region are experienced hosts of a variety of international sport events. The International Triathlon Union World Cup, World Basketball Championships, World Baseball Classic and Road World Cycling Championships are all part

of the region's hosting resumé. The 2007 FIFA Under-20 World Cup broke all tournament attendance records to become one of the largest single-sport events in Canadian history.

At Games time, the experience and expertise already in and around Toronto will combine with the procedures, lessons and, most importantly, dedicated people with sport hosting backgrounds from across Canada, including veterans of the Vancouver 2010 Olympic Winter Games, to make Toronto 2015 one of the most talented and tested host city teams in the world.

### 6. Ideal Competitive Conditions

At Toronto 2015, Pan American athletes will compete in optimal conditions, giving them the best chance to excel. Existing facilities in the Toronto 2015 venue plan are proven and world-class, including venues like the Air Canada Centre, home of the National Basketball Association's Toronto Raptors, and the Rogers Centre which welcomed the World Baseball Classic earlier this year. All new venues will be built to the highest standard in order to meet or exceed International Sport Federation (ISF) requirements and enhance the experience and facilitate the performance of the athletes. The newly-constructed Pan American Village will meet Olympic standards for comfort and convenience and will provide a service-oriented home-away-from-home that is convenient and secure, vibrant and welcoming.

The Pan American Games are scheduled from July 10 to 26, 2015 and the Parapan American Games are scheduled from August 7 to 14, 2015. July and August in Toronto provide long, warm, sunny days and comfortable evenings with an average daytime temperature of 26° C at a competition-ideal altitude of 112 metres above sea level. Athletes will compete in a clean and healthy climate ideally suited for performance.

### 7. Welcoming, Safe Communities

Toronto is famous among global visitors for its safety and cleanliness. *The Economist* magazine ranked Toronto the fifth "most livable" city in the world and the Mercer survey points to Toronto as the best city for personal safety in the Western Hemisphere. The city's neighbourhoods and streets are safe day and night; parks, ravines and a network of hiking trails knit together the city's urban communities. There are bike paths, beaches and iconic architecture along with globally-recognized museums, art galleries and performing arts centres all walking distance from each other. From the third largest theatre district in the world, to one of the highest observation decks on the planet in the CN Tower, and to the internationally-famous Niagara Falls just an hour away, Toronto offers PASO teams and athletes countless reasons to enjoy the world-class setting of the Toronto 2015 Pan American Games.

### 8. Your Hometown in Canada

Toronto is home to a population that speaks more than 140 different languages and people from every one of the PASO countries. Sport is one of the most powerful ways that this multicultural society has taught and united its children, youth and communities. It is impossible to live, work and play in Toronto without seeing – every day in a thousand different ways – that Toronto residents are global citizens. Every athlete who comes to the Games will have a built-in cheering section from his or her own country and culture. Toronto's tapestry of nationalities also enlivens the cultural life of the city, with international festivals like Caribana,

a million-person event that celebrates the Caribbean, and Salsa on St. Clair, a dynamic event that highlights the city's large Latin community.

## **9. Transportation Services - Dedicated Cars and Drivers**

Comprehensive and coordinated transportation services will be provided for the PASO family between the opening of the Pan American Village and three days after the close of the Games. All PASO officials, accredited athletes, team officials and technical officials will be provided with safe, secure and reliable transportation services that ensure timely delivery to and from all accommodations and Games venues. The convenience of the NOC's is a paramount concern for Toronto 2015, so in addition to the standard allocation of dedicated cars and drivers to the individuals holding key leadership positions within PASO, the IOC and the ISF's, Toronto 2015 will provide every NOC with a dedicated car and driver for each of the NOC President and the Secretary General regardless of team size.

The fleet of PASO vehicles will be supported by reserved parking and secure designated transport facilities at the Pan American Village and competition venues, along with designated Pan American lanes linking Pearson International Airport, the Pan American Village, the host hotel and sport venues.

## **10. Enhanced Rate Card**

Toronto 2015 will provide PASO and all NOC's with an "enhanced" rate card system that offers the best rates and greatest convenience in obtaining the services and resources teams might require in Toronto. Toronto 2015 will source and negotiate the services and products on the rate card well in advance of the Games and ensure that the rate card offerings cover all potential team needs, from the latest technology to telecommunications services, and from transportation enhancements to sport-related equipment.

## **Continuing to Build the Brand and Influence of the Pan American Games**

The history of the Pan American Games has been one of building legacies and making champions. Toronto 2015 is ready to add to the growing currency and relevance of the Pan American

Games by implementing specific plans to further enhance the brand, reach and influence of both PASO and the Games. Building on the achievements of Guadalajara and previous Games host cities, Toronto will use a comprehensive knowledge transfer program to hand the Games to the 2019 host city with the Pan American Games movement in a strong position, taking what is already one of the leading sport properties in the world and elevating it to the next phase of its evolution.

### **1. Guaranteed Financial Commitment**

All levels of government – federal, provincial and municipal – are solidly behind Toronto 2015, having already committed 90% of the \$1.4 billion (Cdn) Games budget. The Province of Ontario, Canada's most populous province, has committed to being the Games' deficit guarantor, reflecting the strong commitment of both the government and the Premier.

This is secure support from stable government sources that provides a rock-solid foundation to the Toronto bid and to the 2015 Pan American Games even in the context of a turbulent global economy. It ensures confidence in budgeting and allows for certainty in planning. It ensures that Toronto will be able to execute the 2015 Games with an excellent blend of reliability and ambition.

### **2. Revenue-Driving Market**

Toronto is Canada's financial capital, the third-largest financial market in North America and home to a regional population of 8.1 million people. Over 200 million people are within a three hour flight or one day drive of Toronto, the vast majority of these in the Eastern time zone which is so critical to broadcast television in Canada and the United States. All of this defines a market that is rich with opportunities for sponsorship, private sector partnerships and revenue generation. Particularly in these times of global economic uncertainty, the stability of the Toronto corporate base creates a market particularly well-matched to the Pan American Games; it establishes a financial environment that both helps protect against the volatility of the world economy and generates a wealth of opportunity.

### **3. Media Hub**

Toronto 2015 has ambitious media plans and the capacity to match. As a true global media capital, Toronto boasts six major daily newspapers, four general all-sports television networks, a number of specialty sport networks and one of the first all-sports radio stations in the world. The intensity of the Toronto media market ensures that the communications vehicles, technology and talent will be available to bring the stories of the 2015 Pan American Games to more people in more ways in more parts of the world. It will allow Toronto 2015 to give PASO athletes and sponsors more exposure at home while also offering fans from all corners of the Americas and the Caribbean unprecedented choice in experiencing the Games at home from the comfort and convenience of their living rooms, offices, cafés, community centres and street corners through the use of new media and mobile technology.

### **4. Broadcast of 2011 and 2015**

Toronto's ambitious media plan – which starts long before the 2015 Games – will bring the Pan American Games an Olympic-style presence in both broadcast and web-based media. Toronto 2015 will work with Guadalajara 2011 to arrange for up to 50 hours of coverage from the

2011 Games to be broadcast in Canada to build excitement for the Pan American Games and leverage sponsorships, partnerships and ticket sales for 2015. For the Toronto 2015 Games, the Games broadcast commitment will be to provide more than 300 hours of coverage in English, French and Spanish, and will include the full adoption of the latest web-based and mobile media strategies.

#### 5. Transfer-of-Knowledge and Information Program

Toronto 2015 is committed to ensuring that the impact of the 2015 Pan American Games endures long after the close of the Games. The international aspect of the Toronto legacy plan includes a multi-faceted transfer-of-knowledge program designed to help NOC's strengthen their organizational capabilities.

Toronto 2015 will be an active partner with both the Canadian and PASO sport communities to contribute to the on-going development of resources available to communities and countries that plan to bid for and host major sport events. Toronto 2015 will offer one-on-one assistance to future hosts of both Pan American and regional games, as well as provide seminars and written materials on bidding and hosting best practices.

#### 6. Games Hosting Internships

Individuals from future host organizing committees throughout PASO will have the opportunity to work in staff positions across multiple disciplines with the Toronto 2015 Host Organizing Committee during the preparations for the 2015 Games. The internships could begin as early as 2012, with the program concluding at the close of the Games in 2015. These placements will allow the "intern" to return home with knowledge that can help his or her community bid for, win and host sport and non-sport events.

#### 7. Volunteer Recruitment

The anticipated 19,000 Games volunteers required for Toronto 2015 will include volunteers recruited from diverse communities, with all volunteers participating in an innovative and comprehensive training program that will prepare them for the Games and develop transferable skills that enhance their abilities for future volunteer and professional positions.

The volunteer management modules developed for the 2015 Pan American Games will become part of a web-based service available to sport organizations throughout the PASO community. Specifically, the resource will include modules on key volunteer management issues like recruitment, roles and responsibilities, orientation, training and customer service.

## OUR RESPONSIBILITY

For many athletes, the 2015 Pan American Games will be their first major international competition; for others, it will be the place for striving to qualify for the 2016 Olympic Games or honing their skills in anticipation of Olympic competition. The 2015 Pan American Games will be the place where the best-of-the-best challenge Pan American and world records; to other athletes, the 2015 Games will be their highest level of competition. It will be their best opportunity to wear the colours of their home countries, to march under their flags, to compete in front of huge crowds, to sing their anthems from a medal podium.

We owe it to all of the athletes of the 2015 Pan American Games to deliver a Games worthy of their efforts and dreams. While it is a privilege for any city and nation to host the Pan American Games, it is also a responsibility. Toronto and Canada are ready to accept that responsibility, to exceed expectations and to give the athletes the outstanding Pan American Games they deserve.

Toronto is ready and eager to welcome you to Canada for the seventeenth Pan American Games.

## **SECTION HIGHLIGHTS:**

In 2015, the nations of the Americas and the Caribbean will gather in Toronto, one of the world's most culturally diverse cities, where 46% of the population is foreign-born and there is a local community from every PASO nation. This will be the backdrop of the Games – a city with a stable economy built on the third largest financial centre in North America, a city experienced in hosting major international events, a regional population of more than 8.1 million.





# CANDIDATE CITY

## TORONTO: IDEAL GAMES HOST

Toronto is a global city, one of the top ten in the world, according to *Foreign Policy* magazine's Global Cities Index. As one of only four cities on the index in the Western Hemisphere and the only one outside of the United States, Toronto has the character, culture and technology, along with the corporate support and the talent base to excel as the host of the 2015 Pan American Games.

### TORONTO RANKED IN THE TOP TEN GLOBAL CITIES

The City of Toronto ranked fourth in "Cultural Experience" behind only London, Paris and New York in *Foreign Policy* magazine's annual Global Cities Index, which ranks major cities in business, human, technological, cultural and political categories.

Toronto offers the cultural richness and diversity that ensures a lively and welcoming Pan American Games with crowds ready to support every one of the PASO teams. Toronto's innovation-based economy and cultural sector will be reflected in the planning of the Toronto 2015 Games, including inspiring creative new directions in managing media, technology and the Games legacy. Toronto 2015 will focus on environmental responsibility and sustainability in the pursuit of hosting the "greenest" Pan American

Games ever. Toronto's well-known hospitality ensures that PASO athletes, teams and officials will receive a warm welcome. The city's position as a major global transportation hub, with efficient intra-urban transport and tested customs and immigration procedures, will ensure that teams arrive and get everywhere they need to be easily and swiftly.

Torontonians embrace sport and culture. For decades, the multicultural city has turned to sport to unite communities, to involve children and youth, engage families and seniors, and bring generations together. The culturally-rich city puts world-class museums, iconic architecture, music festivals, one of the world's top film festivals, and regional attractions like the globally-recognized Niagara wine region and the legendary Niagara Falls all within easy reach.

Toronto is a world-class city that is ready for the world-class Pan American Games.

## HISTORY AND GEOGRAPHY

In 2009, Toronto is celebrating the 175<sup>th</sup> anniversary of its incorporation. With an urban heritage that dates back more than 200 years and a history as an Aboriginal Canadian community that extends for centuries before that, the city of today inherits a rich historical legacy.

Situated on the shore of Lake Ontario – one of the largest lakes in the world and part of North America's Great Lakes system – Toronto quickly grew to become one of Canada's most important cities on the strength of an industrial, transportation and finance-based economy. The rise of the railway system in the mid-Nineteenth Century was a significant impetus to Toronto's growth, given its location in the heart of Canada. The early part of the Twentieth Century was a period of tremendous development for Toronto, with a booming manufacturing industry and major investments in cultural institutions such as the Royal Ontario Museum, the Art Gallery of Ontario and the Canadian Opera Company.



#### TORONTO CITY SKYLINE

PHOTO CREDIT: TOURISM TORONTO - RAINA KIRN & WILSON BARRY

As Toronto became the focus of Canada's financial institutions and markets, the local economy served as a magnet to both immigrants and relocated Canadians. By 1976, Toronto had passed Montreal to become Canada's largest city. The capital of the Province of Ontario, Toronto is located just over an hour's drive from the American border and within a one-hour flight of 60% of the North American population.

## SIZE

The Toronto region covers approximately 33,500 km<sup>2</sup>, wrapped around the western end of Lake Ontario, with the City of Toronto accounting for 641 km<sup>2</sup>. While this region is the home to more than 100 distinct municipalities (16 of which have populations of more than 100,000), it is not an entirely urban area. More than a quarter of the region (7,200 km<sup>2</sup>) is environmentally-protected "green belt."

## GETTING TO TORONTO

Toronto's Lester B. Pearson International Airport (named for the Nobel Peace Prize winning former Canadian Prime Minister) is one of the 30 highest-capacity world airports with 33 million passengers using the airport in 2008. The airport is located just 25 km northwest of downtown Toronto. Direct access to the airport is provided by major highways with dedicated entry and exit ramps. The airport road system is integrated into the regional transportation system. The construction of a rail link between Pearson Airport and downtown Toronto is a top priority within the regional transit plan, and will be completed by 2015.

### AIRPORT QUICK FACTS:

- Direct flights from 30 PASO nations
- 15 airlines with flights between Canada and PASO countries
- 277 flights and 40,090 seats per week to Mexico, Central America, South America and the Caribbean
- 7,040 flights and 638,440 seats per week to United States and Canadian destinations

## THE ECONOMIST RANKS TORONTO 5TH "MOST LIVABLE" CITY IN THE WORLD

Toronto is one of the only cities in the Western Hemisphere to make the top ten list of *The Economist* magazine's ranking of 132 cities world-wide on factors including stability, health care, culture, environment, education and infrastructure.

### GEOGRAPHICAL LOCATION

**LONGITUDE:** 79° 23' W (West of Greenwich, England)

**LATITUDE:** 43° 39' N (North of Equator)

**ALTITUDE:** 112m / 367ft above sea level

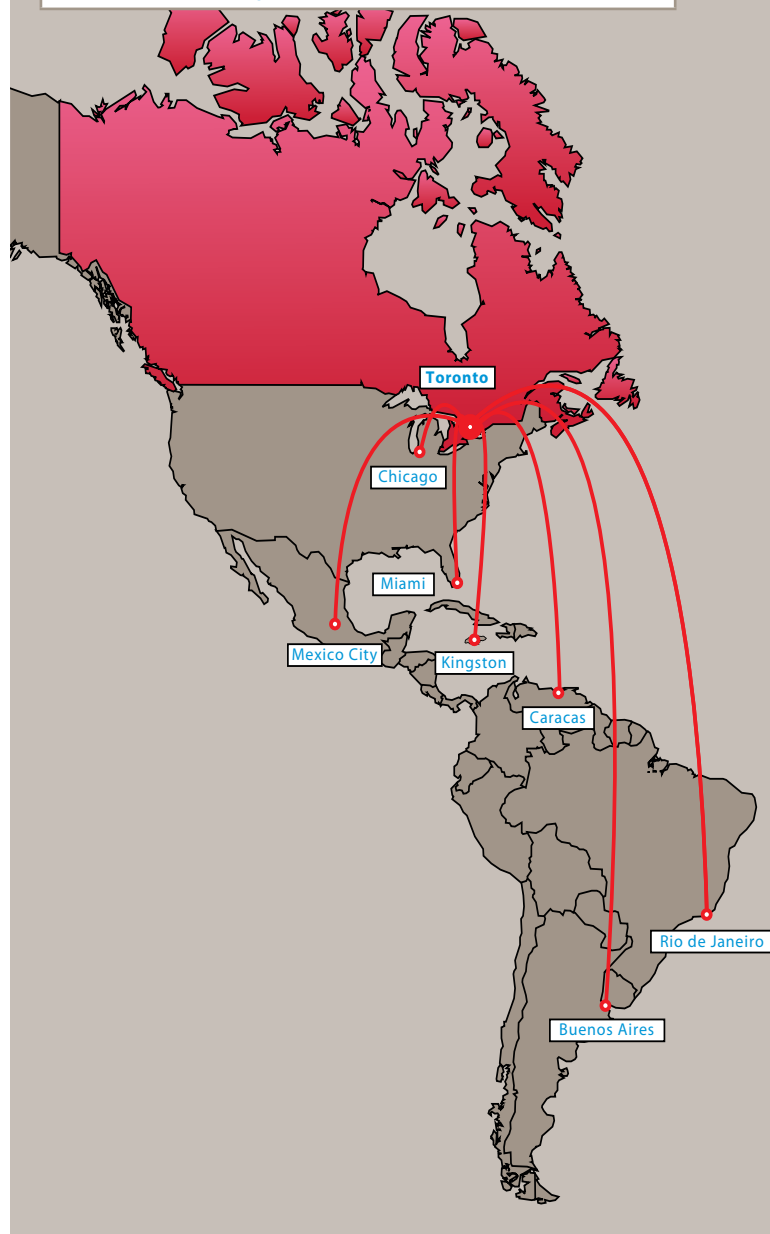

## POPULATION AND IMMIGRATION

Toronto is Canada's largest city and the fifth most populous municipality in North America. The region that surrounds the city, referred to locally as the "GTA" or Greater Toronto Area, is home to more than 5.5 million people (inter-census estimate 2008) with the broader regional

population reaching over 8.1 million people, all living within an hour's drive of the Games area. This regional population represents two-thirds of the population of the Province of Ontario and approximately one-fifth of the population of Canada. The Toronto region will continue to expand in the coming years with projections taking the population to more than 11.5 million people within two decades. The main driver of that growth will be immigration.

The composition of Toronto's population has evolved dramatically over the last four centuries. Originally an important Aboriginal Canadian community, the city's urban origins came with the arrival of settlers from France and, primarily, the United Kingdom. The Twentieth Century turned Toronto into one of the most immigration-friendly cities in the world. Today, the Organization for Economic Cooperation and Development (OECD) calls Toronto the most culturally-diverse city among its member nations.

#### TORONTO: PASO'S HOME AWAY FROM HOME

Approximately 20% of the Toronto region's population was born in the Caribbean, Central America, South America, the United States or Mexico.

More than 100,000 immigrants, representing at least 60 different ethnicities, arrive in the GTA every year, helping to create a cosmopolitan environment in which more than 140 different languages are spoken, and over 90 different faith groups peacefully coexist. Twenty-two percent of the regional population is comprised of first-generation Canadians with at least one parent born outside Canada and a remarkable 52% of Torontonians aged 15 or older are themselves immigrants. With 46% of Toronto's overall population being foreign-born, the city ranks well ahead of cosmopolitan cities like Miami (37%), New York (28%) and London (27%) for its international influence and character.

#### ECONOMY

While retail and wholesale trade is still Toronto's largest single industry group, comprising 15% of the local labour force, the regional economy is making a significant shift toward knowledge-

based enterprise including university-based research, technology and the rise of the "creative class." The professional services sector is now the largest generator of jobs in the City of Toronto.

The regional GDP of \$222 billion (Cdn) is 19% of the national total.

#### TORONTO AND REGION ECONOMY QUICK FACTS:

- Labour Force (2009): 3,138,280
- Largest Industry Group (2008): Retail and Wholesale Trade (15% of all jobs)
- Fastest Growing Industry Group: Professional Services (now 12% of all jobs)
- Unemployment Rate (January 2009): 7.4%
- Per Capita Income (2007): \$35,974
- Retail Sales (2008): \$58.1 billion

Toronto is not immune to the pressures of international economic uncertainty. Yet the city is as well-positioned as any to remain stable and prosperous while contributing powerfully to the international recovery. Toronto's particular strength comes from its economic diversity and its position as the focus of Canada's strong financial sector – five of the country's six largest banks have their headquarters in downtown Toronto, the base of the third largest financial centre in North America.

#### ONTARIO TRADE WITH SOUTH AMERICA, CENTRAL AMERICA & CARIBBEAN

CDN\$		2006	2007
South America	Domestic exports	\$1,038,900,052	\$1,101,828,871
	Total imports	\$3,701,261,852	\$4,099,973,895
	Total trade	\$4,740,161,904	\$5,201,802,766
Central America & Caribbean	Domestic exports	\$531,675,803	\$546,332,989
	Total imports	\$712,968,740	\$775,248,334
	Total trade	\$1,244,644,543	\$1,321,581,323
Mexico	Domestic exports	\$2,126,855,889	\$2,045,131,446
	Total imports	\$13,542,034,534	\$13,911,303,833
	Total trade	\$15,668,890,423	\$15,956,435,279

#### CANADA'S MEDIA CENTRE

Toronto boasts three major national television networks; six major daily newspapers (two with national readership); four general all-sports television networks; no fewer than seven specialty sport networks covering everything from basketball to motorsports, and from combative sports to international sports; and one of the first all-sports radio stations in the world.

The city is so well equipped with production facilities and equipment, along with the associated trades and talent required for the production

of television and film, that Toronto has become known as “Hollywood North” for its ability to support numerous large movie productions simultaneously.

## EDUCATION AND INNOVATION

The Province of Ontario has the most highly educated workforce in the world according to 2006 OECD data, and the Toronto region has the largest concentration of universities and colleges in Canada with 20 certificate, diploma and degree granting post-secondary institutions. In the last decade and a half, both the Canadian federal government and the Ontario provincial government have made significant investments in the learning and innovation infrastructure of the province. Four Nobel Laureates in scientific disciplines have achieved their research breakthroughs in Ontario. Increasingly, the Toronto region is becoming home to cutting-edge innovation companies working in everything from consumer electronics (companies like RIM, the inventors of the Blackberry smartphone) to biotechnology (companies like Biovail, a pioneering pharmaceutical company based in Canada with operations in the United States, Barbados and Puerto Rico).

The World Intellectual Property Organization (WIPO) measures innovation in a survey of global cities by tallying patents received, one of the most direct measures available for quantifying innovation. Toronto has ranked in the top twenty worldwide for the last four years.

### WORLD INTELLECTUAL PROPERTY ORGANIZATION (WIPO) INNOVATION RANKING – 2008 (SELECT CITIES)

1. Tokyo, Japan
4. New York, United States
8. Boston, United States
- 17. Toronto, Canada**
24. Montreal, Canada
33. Mexico City, Mexico
34. Santiago, Chile
35. Sao Paulo, Brazil
40. Caracas, Venezuela

## SAFE CITY

Toronto offers an outstanding quality of life: green and vital neighbourhoods, quality housing, an efficient public transport system, superior schools and health-care facilities, numerous parks and playgrounds, and great recreation opportunities.

According to the 2008 Mercer survey on global livability, an analysis that involves 215 cities worldwide, Toronto rates as the best city for personal safety (a measure that incorporates ratings of stability, crime and law enforcement) in the Western Hemisphere.

## CULTURAL INSTITUTIONS AND EVENTS

Toronto is a world cultural centre, ranked fourth for “cultural experience” in the Global Cities Index behind only London, Paris and New York. The city’s arts and cultural activities are housed in breathtaking buildings designed by some of the world’s great architects, including Frank Gehry (the Art Gallery of Ontario), Daniel Libeskind (the Royal Ontario Museum), Arthur Erickson (Roy Thomson Hall) and Diamond and Schmidt (the brand new Four Seasons Centre for the Performing Arts, home of the Canadian Opera Company and the National Ballet of Canada) among others. Each of these cultural gems is in close proximity to key Games venues.

The city is also filled with scores of theatres, both small and large, making Toronto the third-largest live theatre centre in the world behind London’s West End and New York’s Broadway.

The rich festival program in Toronto lends the city a vibrant, high-profile and international character.

The **Toronto International Film Festival** is among the most prestigious film festivals in the world. Every September, the festival attracts a who’s-who of global cinema to its premieres, galas and parties. With its flawless execution of the rigorous security and high-end hospitality demands of the festival for more than thirty years, Toronto is well rehearsed in providing VIP visitor treatment.

The **Caribana Festival** is an exciting two-week explosion of Caribbean music, cuisine and visual and performing arts. Now in its 42nd year, it has become a major international event and the largest festival of its kind in North America, attracting more than 1.3 million people from the Toronto region and around the world.

The **Luminato Festival of Arts and Creativity** is the world’s newest international multidisciplinary arts festival. In 2007, the inaugural festival attracted more than one million participants to more than 100 events, including ten world premieres and three Canadian premieres. Luminato’s program encompasses a broad spectrum of creative expression including music, dance, theatre, film, literature, visual arts and lectures.



↑ LUMINATO FESTIVAL 2007  
PHOTO CREDIT: TOURISM TORONTO

The **Salsa on St. Clair** festival attracts more than 250,000 people to the streets of Toronto for a free family street party celebrating Toronto's Latin cultures. Scheduled for early July, the festival features pulsating music, passionate dancing, fiery foods, a Latin market, a children's area and an interactive football pavilion.

The **Canadian Aboriginal Festival** has been one of the country's most dynamic cultural events for a decade and a half. Held annually in November in the Rogers Centre (site of the 2015 Pan American Games Opening and Closing Ceremonies), the festival attracts people from all cultures to celebrate the art, history and culture of North America's Aboriginal peoples.

## EXPERIENCE IN HOSTING INTERNATIONAL EVENTS

Canada has a history of successfully staging major international games and sport events and the Toronto region has played host to many of them. From sailing to football, Toronto organizers are constantly delivering successful events and learning with each experience while Toronto fans support international events with remarkable enthusiasm, owing in part to the fact that many Torontonians cheer for Canadian athletes as well as those from their home nations.

The list of Toronto's non-sport hosting experience is also significant, and includes the 17th World Youth Day from July 23 to 28 in 2002. This Catholic Youth Festival involved 176,100 registrants and drew one million people for an overnight vigil and papal mass.

Toronto has hosted the G7 World Economic Summit (1988) and next year will host the 2010 G8 Summit (with the leaders of France, Germany,

Italy, Japan, Russia, the United Kingdom, the United States and Canada) at a retreat just north of the city in Huntsville, Ontario. The city is also a destination for major international conferences including the 2006 XVI International AIDS Conference and the 2001 International Association of Chiefs of Police Annual Conference.

Toronto also has extensive experience in hosting sport events, including the International Bowl of American football in 2007, 2008 and 2009; the 2004 World Cup of Ice Hockey; the 2006 Barclays Churchill Cup of rugby; and the Breeders Cup World Thoroughbred Championship of horse racing in 1996. Add to that annual events such as the ATP/WTA Masters Series Rogers Cup of Tennis, Canadian Open golf on the PGA (Professional Golfers Association) Tour, and the Grand Prix of Toronto in open-wheel automobile racing and Toronto is a tested event host by any measure and ready to apply that experience to the 2015 Pan American Games.

## PUBLIC SUPPORT AND WELCOMING ATTITUDE

Torontonians overwhelmingly support the city's bid for the 2015 Pan American Games. The municipal, provincial and federal governments – with all-party support – each endorsed participation in the bid, committing both time and financial resources to ensuring the success of both the Toronto 2015 bid and the Games.

### RECENT INTERNATIONAL SPORT HOSTING EXPERIENCE

- 2009: World Baseball Classic
- 2007: FIFA U-20 World Cup
- 2006: Junior Pan American Artistic and Rhythmic World Gymnastics Championships
- 2003: Road World Cycling Championships
- 1999: Royal Canadian World Rowing Championships
- 1999: FISA World Rowing Championships
- 1998: CONCACAF Women's Football Championships



↑ WORLD YOUTH DAY, 2002  
PHOTO CREDIT: CITY OF TORONTO ARCHIVES

Locally, a poll conducted by Ipsos Reid Research indicated that 80% of respondents in the general population support the bid to host the Pan American Games in 2015.

Toronto has a robust tourism sector built on outstanding service to millions of visitors each year. In 2007, the Toronto region welcomed 19.5 million visitors. The City of Toronto and nearby Niagara Falls are Canada's two most-visited tourist attractions. As a result, the region's hotels, restaurants, public transportation, services and airports are well-experienced and well-prepared to welcome visitors from around the world, in their own languages and styles.

### TORONTO: THIRD MOST POLITE CITY IN THE WORLD

A 2007 study conducted by *Reader's Digest* magazine tested behaviour in 36 cities worldwide for politeness, courtesy and customer service. Toronto finished third behind New York, United States and Zurich, Switzerland.

### A CITY OF VOLUNTEERS

Ontario has a large volunteer workforce, with 25% of adult Ontarians serving in at least one formal volunteer capacity. Through volunteer-intensive events such as the 2003 Road World Cycling Championships and the annual Canadian Open event on the PGA Tour, the Toronto region has developed an extensive database of trained and experienced volunteers numbering in the tens of thousands. There is also a strong contingent of volunteers that is experienced in delivering important national and regional sport events from the annual Scotiabank Toronto Waterfront Marathon to the Canadian Dragon Boat Championships to the Longboat Toronto Island Run, a 10 km race named in honour of one of Canada's greatest Aboriginal athletes, Tom Longboat, a distance runner who competed in the 1908 Olympics and won the 1907 Boston Marathon in record time. These volunteers – leaders in the Toronto community – are available to support the Pan American Games in 2015 with their tested skills and outstanding enthusiasm.

Toronto 2015 will involve more than 19,000 volunteers. Many of these volunteers will have sport-specific knowledge and the ability to speak more than one language.

### BID ORGANIZATIONAL STRUCTURE

The Toronto 2015 Pan American Games Bid Corporation is a not-for-profit corporation. Its mandate is to develop and lead the Toronto bid for the 2015 Pan American Games.

The foundation of the Bid Corporation is a strong partnership among the three levels of government: municipal, provincial and federal, along with the Canadian Olympic Committee. In assembling the bid team, Toronto 2015 has involved people with a wide range of expertise and talents, covering areas from sport management to infrastructure development, from finance to revenue generation, from technology to marketing, and from event management to broadcasting.

Toronto 2015 has also established a transition plan that will ensure, if Toronto wins the privilege of hosting the 2015 Pan American Games, that the bid team will be able to initiate the swift transformation from bid corporation to host organizing committee. Toronto will lose no time in turning from the task of bidding to hosting.

### TORONTO 2015 BID LEADERSHIP BIOGRAPHIES

#### The Honourable David Peterson - Chair, Toronto 2015 Pan American Games Bid Corporation



Mr. Peterson, a former Premier of Ontario, was asked by the current Premier to lead the Toronto 2015 bid. Mr. Peterson is a senior partner and Chairman of the Toronto law firm of Cassels Brock & Blackwell LLP, where he practices corporate/commercial law. He also is Chancellor of the University of Toronto and a director of St. Michael's Hospital, the Shaw Festival and the Toronto Community Foundation. Mr. Peterson was elected as a Member of the Ontario Legislature in 1975 and became leader of the Ontario Liberal Party in 1982. He served as Premier of the Province between 1985 and 1990, overseeing a very active period of reform. He also was the founding Chairman of Toronto's National Basketball Association team, the Toronto Raptors. In 2009, Mr. Peterson was appointed to the Order of Ontario, being recognized for his public and community service contributions.

#### Jagoda Pike - President and Chief Operating Officer, Toronto 2015 Pan American Games Bid Corporation



Prior to joining the Bid in October 2008, Jagoda Pike served as President of Star Media Group and Publisher of the *Toronto Star*, Canada's largest newspaper. While with Torstar, Ms. Pike also has held the roles of Executive Vice-President of Newspapers and Publisher of the *Hamilton Spectator*. Ms. Pike was also the past chair of the Canadian Newspaper Association and a member of a number of community organization boards. As President and Chief Operating Officer of the Bid, Ms. Pike leads day-to-day operations and development of Bid plans, applying her experience from her work on Commonwealth Games bids.

## BID ORGANIZATIONAL STRUCTURE:

THE TORONTO 2015 BID CORPORATION IS MADE UP OF STRONG PARTNERSHIPS AT THE LOCAL, PROVINCIAL AND NATIONAL LEVELS.

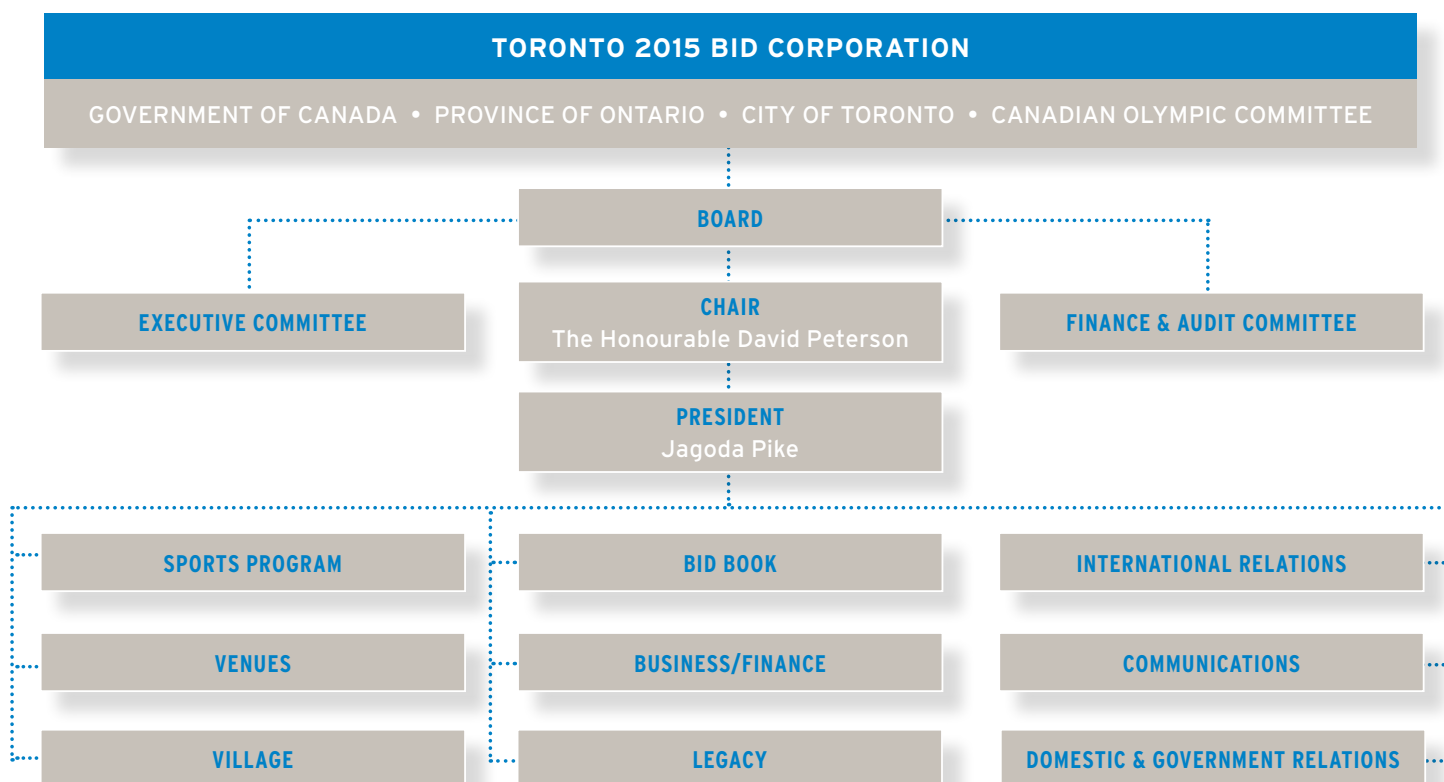

## BOARD OF DIRECTORS

**The Honourable David Peterson** – Chair

**Jagoda Pike** – President & Chief Operating Officer

**David Braley** – President, Orlick Industries Limited, owner of the Canadian Football League's BC Lions

**Michael Chambers** – President, Canadian Olympic Committee

**Charmaine Crooks** – Five-time Olympian & Pan American Games Athlete – Athletics

**Alvin Curling** – Former Ambassador to the Dominican Republic and former Speaker of the Ontario Legislature

**Ivan X. de Souza** – President & CEO, Brazilian Carnival Ball

**Patrick Dillon** – Business Manager & Secretary, Provincial Building and Construction Trades Council of Ontario

**Marcio Froes** – President, Labatt Breweries of Canada

**Joe Halstead** – Community Leader; Chair, Caribana Festival and Chair of Ontario Place

**Sandra Levy** – Director, Human Resources, Decoma International Corporation and Field Hockey Olympian

**Debbie Low** – President & CEO, Canadian Sport Centre Ontario and Canada's Chef de Mission, 2008 Paralympic Games

**Cynthia Morton** – Deputy Minister, Ontario Ministry of Health Promotion

**Alexandra Orlando** – Olympian & Pan American Games Athlete – Rhythmic Gymnastics

**Gordon Peterson** – Executive Board Member, Canadian Olympic Committee

**Chris Rudge** – CEO & Secretary General, Canadian Olympic Committee

**Javier San Juan** – President & CEO, L'Oreal Canada

**Anatol von Hahn** – Executive Vice-President, Latin America, Scotiabank

**Victoria Winter** – Pan American Games Athlete – Dressage

**Andrew Wright** – Executive Vice-President & Managing Director, CB Richard Ellis

## **SECTION HIGHLIGHTS:**

Canadians have built their passion for sport from the ground up. With the strength of hundreds of grassroots sport organizations ready to support the Games as volunteers, officials, leaders and fans, all three orders of government in the country have committed enthusiastically to Toronto 2015. That government support is guaranteed and substantial, with all political parties united in their vision of hosting a great Pan American Games in Canada.





# DOMESTIC CONDITIONS

Since it became a nation on July 1, 1867, Canada has been a remarkably peaceful and stable democracy. For the first 64 years of its existence, Canada recognized its origins as a British colony by remaining formally connected to, though functionally independent of, the British Parliament. In 1931, the *Statute of Westminster* granted Canada greater independence in creating laws and managing the affairs of the nation, but it was not until 1982 that Canada patriated its constitution. The *Constitution Act: 1982* severed Canada's connection to the British Parliament and, significantly, entrenched the landmark *Charter of Rights and Freedoms* in the constitution.

## CANADA BY THE NUMBERS

- 2007 Population: 32,976,026
- 30.4 million international visitors in 2007
- Second largest country in the world by area: 17,075,000 km<sup>2</sup>
- Longest coastline of any country in the world: 243,042 km
- Most fresh water surface area of any country: 891,163 km<sup>2</sup>

The Charter describes a comprehensive set of rights and freedoms that in many ways define the Canadian character and domestic conditions. The “Fundamental Freedoms” of the Charter include freedoms of conscience, religion, thought, belief, opinion, expression, peaceful assembly and association. The Charter also prescribes democratic rights, mobility rights, legal rights and rights related to equality and language.

Canada's guiding documents and philosophies have played key roles in preparing Toronto to host the 2015 Pan American Games. They have encouraged the immigration patterns that have resulted in the diverse, cosmopolitan makeup of the Toronto region. They have helped turn Canada into a leader in access, programming and opportunities for people with disabilities,

thus making Toronto an outstanding match for the Parapan American Games. They have helped create a national identity that encourages a welcoming, respectful and accommodating environment for all cultures, ethnicities, creeds and languages. That identity ensures that the decision-making processes that shape Toronto 2015 are transparent and accountable, and that a Toronto Games have the ability to forge partnerships both within Canada and in the international community in ways that will benefit the Pan American Games significantly.

## THREE LEVELS OF GOVERNMENT COMMITTED TO TORONTO 2015

Toronto 2015 has support from all three levels of Canadian government and all-party support in both the Ontario Legislature and Canada's national Parliament.

Canada's domestic conditions make it an ideal host for an international, multi-sport event on the scale of the Pan American Games. All three levels of government are aligned behind Toronto 2015, bridging political party lines to ensure the stability of government support for both the bid and the Games, from the first day of bid activity to the Closing Ceremony in 2015.



TORONTO CITY HALL  
PHOTO CREDIT: CITY OF TORONTO PHOTOGRAPHIC SERVICES

## POLITICAL INSTITUTIONS

### The Government of Canada

Canada is a federation of ten provinces and three territories. The central federal government conducts Canada's international relations, plays the lead role in managing the country's infrastructure, economy, defense and immigration. The federal government has three branches: a Legislature, composed of the elected House of Commons (also referred to as Parliament) and the appointed Senate; an Executive composed of the Prime Minister and Cabinet; and an independent Judiciary, headed by the Supreme Court of Canada.

### Provincial and Territorial Governments

The thirteen provincial and territorial governments have lead responsibility for social services, education, health care, cultural policies, roads and highways, and the promotion of economic development. Each provincial and territorial government in Canada has a structure similar to that of the federal government except for the absence of a provincial equivalent to the Senate. The provinces have their own judiciary with law-making powers that are protected by the *Constitution Act*.

### Municipal Governments

Municipal governments, like the City of Toronto, provide a wide range of public services including social welfare programs, policing and local transportation. Municipal governments are most directly involved in responding to the practical needs of citizens, businesses and visitors. They are responsible for such matters of daily importance as water and wastewater, local roads and infrastructure, public libraries, sport and recreation programming and many social services. In most of these areas, municipalities work within standards set by one or both of the other orders of government, thus ensuring, for example, that all municipal water plants in Ontario meet the same rigorous standards for safety and quality.

### Aboriginal Peoples

The Aboriginal peoples of Canada – including the First Nations, Inuit and Métis – represent almost 4% of the country's population – more than a million people. National representative bodies of Aboriginal people in Canada include the Assembly of First Nations, the Inuit Tapiriit Kanatami, the Métis National Council, the Native Women's Association of Canada, the National Association of Friendship Centres and the Congress of Aboriginal People. First Nations

political organizations are spread throughout Canada and vary in political standing, viewpoints and reasons for forming. First Nations communities negotiate with the Government of Canada over all matters concerning land, entitlement and rights.

### Non-Governmental Organizations

In addition to its public and governmental institutions, Canada recognizes tens of thousands of non-governmental organizations, including more than 84,000 registered charities, many of which are Toronto-based. These organizations, often formed at the grassroots level, provide much of the leadership and support for sport, recreational and cultural activities in the country. Though independent and accountable to their own members and participants, they may receive varying degrees of funding from federal, provincial and municipal governments. This network of non-governmental organizations is a vital component of Canadian democracy and a critical element of staging an event of the size, complexity and profile of the Pan American Games.

The organizational infrastructure and volunteer talent pool represented in this vast resource of Canadian not-for-profit organizations will provide a significant part of the human and intellectual capital required to plan, manage and organize the 2015 Pan American Games.

### Sport Organizations

Sport in Canada is organized at all levels. The Canadian Olympic Committee (COC) is the National Olympic Committee (NOC) which oversees the development of Canada's high performance athletes. The COC works closely with each of the country's National Sport Organizations (NSO) (including an NSO for every PASO sport) and Sport Canada (an arm of the federal government) to provide programs and services to Canadian Olympic-level athletes. The provincial governments work with provincial sport organizations to develop "next generation" high performance athletes as well as developing sport at the grassroots level. Local or regional sport organizations work with their member clubs to promote their sports at the local level, recruiting both recreational and competitive athletes. Many municipalities fund community-based sport programs in order to increase sport participation.

At the 2007 Pan American Games in Rio de Janeiro, Canada finished 4th in the overall medal count with 138 medals. In 2008 at the Olympic Games in Beijing, Canada placed 14th in the overall medal count with 18 medals.

## POLITICAL PARTIES

As a country committed to freedom of opinion, expression and association, Canada currently has 19 registered political parties. No political party is banned. While many federal political parties have direct provincial counterparts, this is not always the case – a party may function within a particular province, but not at the federal level or vice versa.

There are currently four political parties represented with seats in the federal House of Commons and five political parties that each received more than 6.8% of the popular vote in the most recent federal election (October 14, 2008).

In Ontario, there are three parties represented with seats in the Legislature. The most recent election was held on October 10, 2007.

All parties represented in both Canada's House of Commons and Ontario's Legislature support the Toronto 2015 Pan American Games bid.

## FEDERAL POLITICAL PARTIES

**The Conservative Party – Government of Canada:**  
Since February 2006 the Conservative Party of Canada (CPC) has formed the government. The CPC holds 143 of 308 (46%) seats in the House of Commons. The Prime Minister of Canada is The Right Honourable Stephen Harper. The Government of Canada strongly supports Toronto's bid to host the 2015 Pan American Games.

### The Liberal Party – Official Opposition:

The Liberal Party of Canada is the Official Opposition in the House of Commons. The Liberal Party holds 77 of 308 (25%) seats in Parliament. The leader of the opposition is Michael Ignatieff. The Liberal Party of Canada supports Toronto 2015.

### Other Federal Political Parties:

- The Bloc Québécois holds 49 of the 308 seats in Parliament
- The New Democratic Party holds 37 seats in Parliament
- The Green Party holds no seats in Parliament, but received 6.8% of the popular vote in the most recent election

## PROVINCIAL POLITICAL PARTIES

### The Liberal Party – Government of Ontario:

The Liberal Party of Ontario was re-elected with a majority government on October 10, 2007 capturing 71 of 107 (66%) seats in the Provincial Legislature. The Premier of Ontario is The Honourable Dalton McGuinty. The Government of Ontario strongly supports Toronto 2015, and is the deficit guarantor of the Toronto 2015 Games.

### The Progressive Conservative Party – Official Opposition:

The Progressive Conservative Party of Ontario holds 26 of 107 (24%) seats in the Provincial Legislature. The Progressive Conservative Party of Ontario supports Toronto 2015.

### The New Democratic Party of Ontario:

The New Democratic Party (NDP) of Ontario holds 10 of 107 (9%) seats in the Provincial Legislature. The NDP supports Toronto 2015.

## MUNICIPAL GOVERNMENT

Toronto's municipal government has 44 elected city councillors who, along with Mayor David Miller, make up Toronto City Council. The council voted overwhelmingly to support the city's bid for the 2015 Pan American Games.

## ELECTIONS

Canadian jurisdictions have fixed election dates so that elections occur on a regular cycle (usually every four years). Federal and provincial elections are usually in October with municipal elections taking place every four years in November.

### CALENDAR FOR UPCOMING ELECTIONS (UP TO 2015)

JURISDICTION	DATE OF NEXT ELECTION
<b>Toronto:</b> Mayor	November 2010 and 2014
<b>Ontario:</b> Premier	October 2011
<b>Canada:</b> Prime Minister	October 2012



↑ CANADA'S PARLIAMENT BUILDING



↑ ONTARIO'S LEGISLATIVE BUILDING

## **SECTION HIGHLIGHTS:**

Immigration has shaped Canada's history and identity, creating a country that cares deeply about both the people who arrive at the nation's borders and about Canada's relationships with the international community. With friendly and tested processes for welcoming millions of foreign visitors who come to Canada annually, the PASO family will enter Canada for the 2015 Pan American Games efficiently, using a system that respects all visitors' time and cultures.



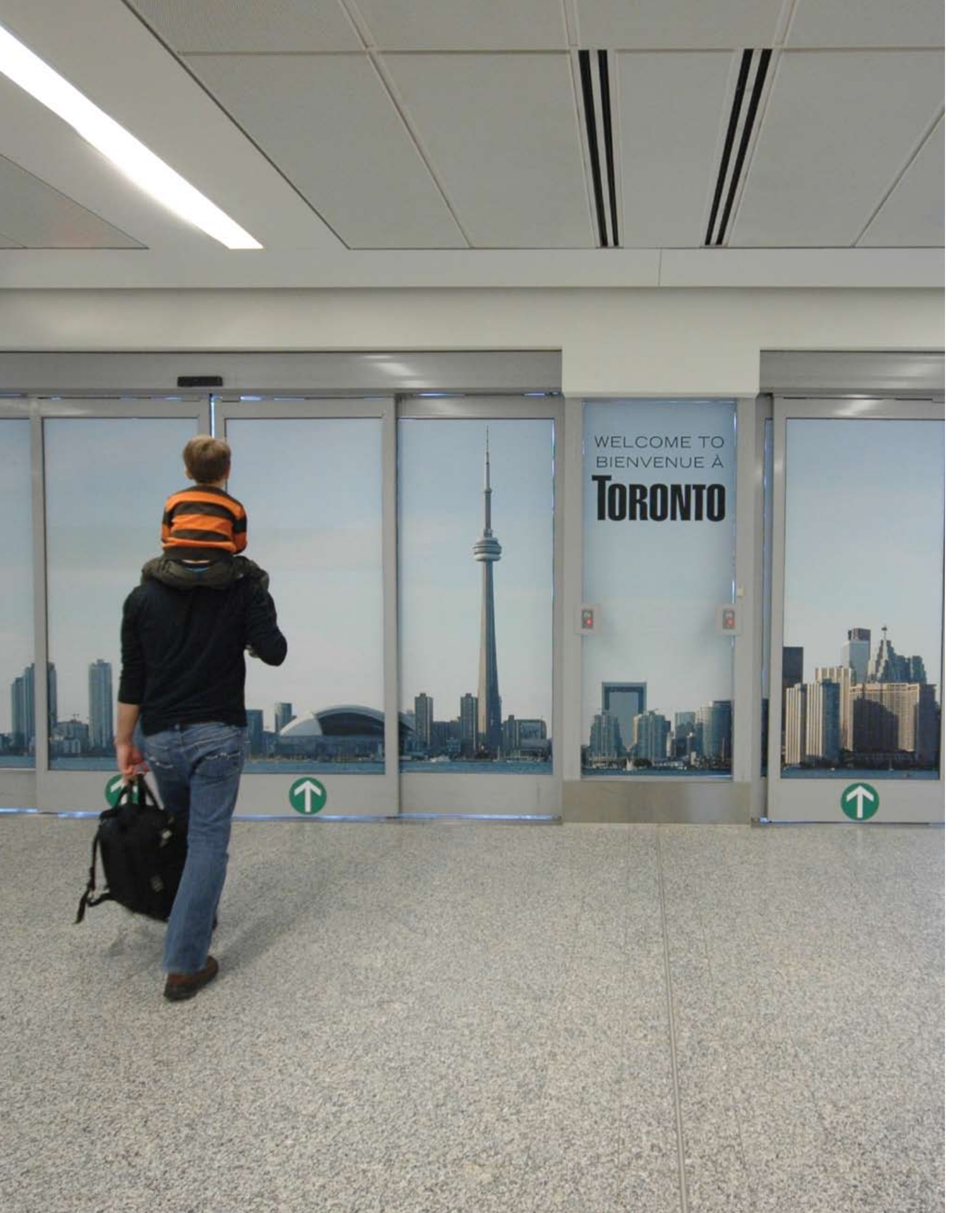

WELCOME TO  
BIENVENUE À  
**TORONTO**

# IMMIGRATION AND CUSTOMS

## IMMIGRATION AND CUSTOMS

In keeping with PASO regulations, the Government of Canada and Toronto 2015 will work to ensure the timely processing of applications for the entry into Canada of athletes, coaches, officials, judges, National Olympic Committee Presidents and Secretaries General, representatives of the media and other participants duly accredited by their respective National Olympic Committee (NOC) for the duration of the Games.

Canada has a long history of welcoming visitors and immigrants from around the globe. This has helped Citizenship and Immigration Canada develop one of the world's most efficient and user-friendly processes for facilitating the entry of foreign travelers into the country.

Toronto 2015 has a clear mission for the immigration and customs processes of the Pan American Games: to move both Pan American people and goods into Canada in a timely and convenient manner. The Games-specific processes and services that Toronto 2015 has designed and adopted support this mission and also reflect both current global security concerns and Canada's history as a nation that is welcoming to visitors from around the world.

From the moment athletes, officials, coaches, dignitaries, media, team members and PASO family arrive in Canada as guests of the Toronto 2015 Pan American Games, they will receive a warm Canadian welcome. The Games' immigration and customs procedures will respect the Pan American Games accreditation process and, through the cooperative efforts of the Canada Border Services Agency, the Canada Revenue Agency and the Toronto 2015 team, will facilitate the enhanced convenience, timeliness and efficiency of processing both people and goods as they enter Canada.

## IMMIGRATION REGULATIONS

Canada welcomes millions of foreign nationals into the country every year as tourists, students and temporary workers. Everyone who comes to Canada enters the country through the provisions of the *Immigration and Refugee Protection Act*. The act describes the requirements and exceptions for visitors regarding the application for and acquisition of travel visas.

The Government of Canada and Toronto 2015 will work together to ensure smooth and timely processing of applications for entry into Canada for the Pan American Games by members of the PASO family and any other Games participants duly accredited by their respective National Olympic Committees.

## VACCINATION REQUIREMENTS

There are no vaccination requirements for visitors staying less than six months in Canada. Similarly, when the duration of a visit is less than six months, no medical examination is required, unless the applicant is planning to work in an occupation in which the protection of public health is essential.



TORONTO PEARSON AIRPORT - ARRIVALS  
PHOTO CREDIT: GREATER TORONTO AIRPORT AUTHORITY

## IMPORTATION OF GOODS

For the 2015 Games, the Canada Border Services Agency and Toronto 2015 will work together to facilitate the temporary importation, by members of the PASO family, of all materials and equipment related to their participation in the Games. These items may include, but are not limited to, firearms and ammunition for competitors in the shooting events, medical supplies, computers, computer software and photographic equipment.

Goods being imported temporarily, as long as they are not being imported for sale, lease or processing, will qualify for customs duty-free entry. As well, Canadian regulations provide for relief from customs duties, excise taxes and the Goods and Services Tax (GST) on goods imported permanently into Canada for the Games. This has long been the Canadian practice for international sport events and it will be part of the Toronto 2015 procedures.

### Drugs and Medical Equipment

There are no restrictions on bringing over-the-counter medications into Canada. Prescription medication should be in the original packaging with a label that describes the prescription. If this is not possible, then carrying the prescription or a letter from the prescribing doctor will suffice.

Drugs, including narcotics and other products such as medical devices controlled by the *Food and Drugs Act* and the *Controlled Drugs and Substances Act*, are not allowed into Canada without proper authorization and documentation. The Health Canada Regional Operations Centre for Ontario, located in Toronto, will work directly with any members of the PASO family who will be required to bring these drugs or products into Canada for the Pan American Games.

### Equine

Toronto is an active gateway for equine import into Canada. Toronto's Pearson International Airport has the expertise and capacity to receive and transport horses safely and efficiently. Toronto 2015 and the Greater Toronto Airport Authority (GTAA) will work together to ensure that horses taking part in the equestrian events will receive appropriate attention, processing and handling.

Well in advance of the Games, Toronto 2015 will provide all PASO nations with a list of required equine vaccinations and certificates of health, along with a detailed description of any applicable quarantine processes.

### EQUINE AIR TRAVEL

Toronto's Pearson Airport has the capacity to handle more than 35,000 horses a year. That means the airport's facilities and experienced staff can manage the arrivals and departures of approximately 100 horses a day.



IAN MILLER, 1999 PAN AMERICAN GAMES GOLD MEDALIST - EQUESTRIAN  
PHOTO CREDIT: CANADIAN OLYMPIC COMMITTEE



TORONTO PEARSON AIRPORT - ARRIVALS & DEPARTURES  
PHOTO CREDIT: GREATER TORONTO AIRPORT AUTHORITY



## **SECTION HIGHLIGHTS:**

The athletes of the Toronto 2015 Pan American Games will compete in weather conditions that are optimal for both competition and spectators: warm daily temperatures, fifteen hours of daylight, and little chance of precipitation. With an altitude of 112 metres above sea level and excellent air quality, the local environment will be an asset to high performance, achieving personal bests, competing with intensity and setting Games records.

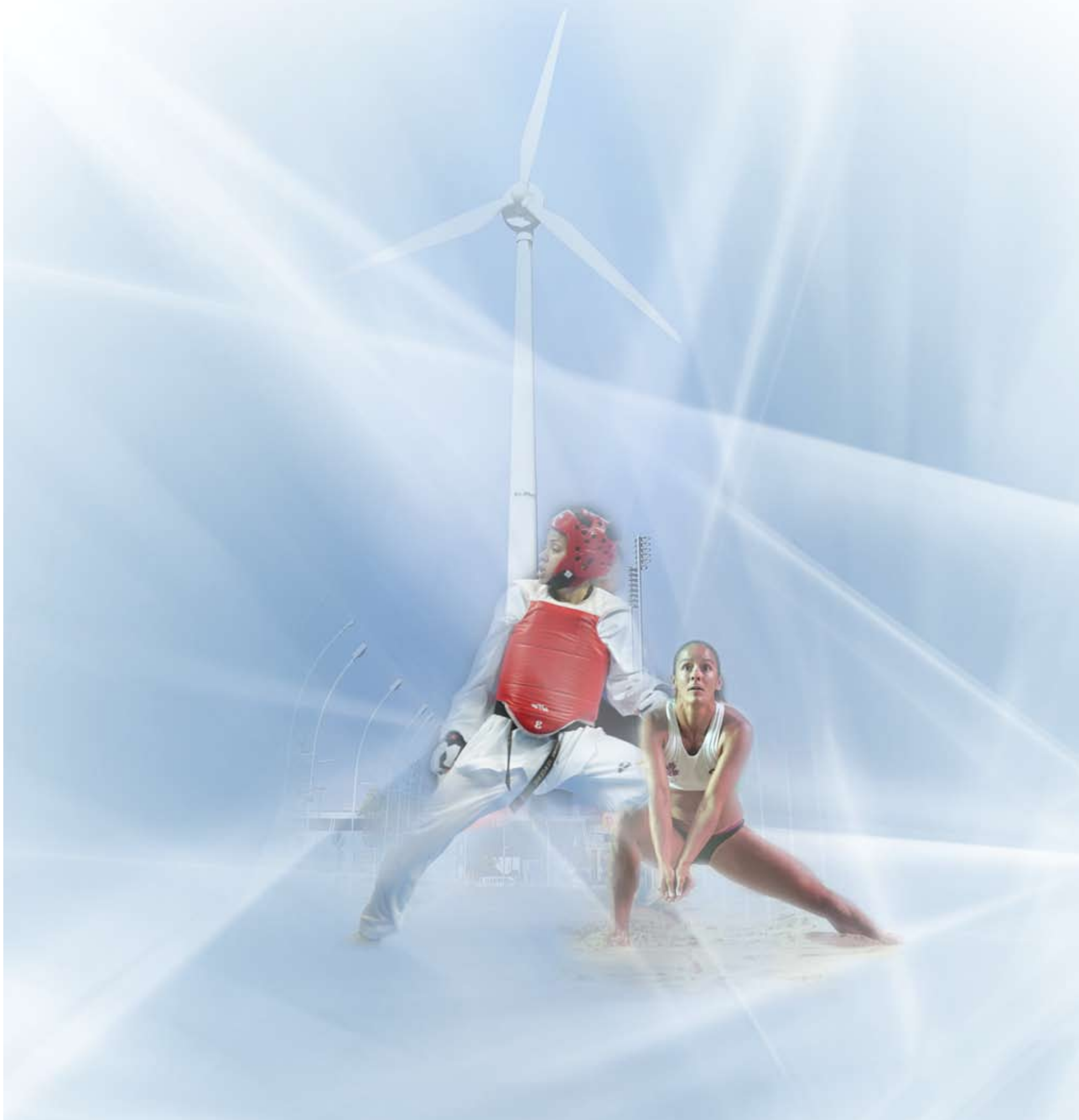



# CLIMATE AND THE ENVIRONMENT

## CONDITIONS FOR COMPETITION

July and August in Toronto are the peak of the Canadian summer and present optimal conditions for athletic competition. With long, warm, dry days and approximately 15 hours of daylight (sunrise around 6:00 am and sunset around 9:00 pm), the weather is an asset to both the performance of athletes and the comfort of spectators. At 112 m (367 ft) above sea level, downtown Toronto's altitude is similar to the sites of many major international competitions, ensuring that athletes will compete in conditions that are both familiar and comfortable, particularly for endurance athletes. The topography of the region, which is mostly flat with some altitude changes around ravines, river beds and the Niagara Escarpment, provides both the consistency of flat terrain and the challenge of steep terrain (as appropriate) for events such as mountain biking and road cycling.

The Toronto 2015 Pan American Games period is July 10 to 26, 2015.

At 112 m (367 ft) above sea level, downtown Toronto's altitude ensures that athletes will compete in conditions that are both familiar and comfortable, particularly for endurance athletes.

Toronto is situated on the northern shore of Lake Ontario, the 14th largest lake in the world and one of the Great Lakes. With a surface area of approximately 19,000 km<sup>2</sup> (7,350 mi<sup>2</sup>), the lake is a moderating influence on the city's summer temperatures, particularly

in the waterfront area that is the location of high-profile venues like the Rogers Centre, the Air Canada Centre and the Pan American Village. Lake Ontario also offers a variety of conditions for sailing competition and a magnificent backdrop for the Games' cultural activities.

## CLIMATE DETAILS

Toronto experiences four distinct seasons, with January being the coldest month of winter and July being the warmest month in the summer.

### JULY AVERAGE WEATHER CONDITIONS

- Daytime high: 26.4° C (79° F)
- Average daily temperature: 22.2° C (72° F)
- Average number of days in July with more than 5mm of rain: 3
- Average wind conditions:
  - 8:00 am to 11:00 am: 11.4 km/hr
  - 11:00 am to 4:00 pm: 15.2 km/hr
  - 4:00 to 7:00 pm: 10.1 km/hr

During the period of the Toronto 2015 Pan American Games – July 10 to 26 – average conditions are optimal for all summer sports: daytime high temperatures average 26.4° C (79° F) with a 24-hour average temperature of 22.2° C (72° F). The average daily low is 17.9° C (64° F).

The summer months provide occasional periods of hot and humid weather; an average year will see 4.6 days in July with temperatures exceeding 30° C (86° F), while average monthly rainfall for July is just 67 mm. One in three days, on average, will offer some precipitation, but only one day in nine has rainfall greater than 5 mm.



30-STOREY URBAN WIND TURBINE  
PHOTO CREDIT: EXHIBITION PLACE/DIRECT ENERGY CENTRE

## ENVIRONMENTAL STANDARDS

### Water Quality

The City of Toronto manages the largest drinking water treatment system in Canada and achieves standards for water quality far beyond those required by provincial regulations. Toronto conducts nearly 300,000 water quality tests annually to measure 300 different quality variables (legislation requires testing for only 72 variables). In key measures such as turbidity (a measure of cloudiness), the City of Toronto's water is ten times better than the provincially-mandated standard.

Toronto's commitment to water quality includes not just its drinking water, but the water along its waterfront as well. One of the most visible results of the city's work in protecting its natural water resources is that six Toronto beaches have earned the international Blue Flag distinction. The Foundation for Environmental Education runs the Blue Flag program out of Denmark and works toward sustainable development at beaches and marinas around the world through the application of strict criteria dealing with water quality, environmental education, environmental management, safety and other services.

### Air Quality

The Province of Ontario achieves air quality ratings of "good" or better 93% of the time. The United Kingdom-based Climate Group has ranked Toronto as one of the top 10 low carbon leaders among global cities. Over the last 30 to 40 years, as the environmental movement has become increasingly prevalent both in Toronto and worldwide, the air quality in Toronto has improved dramatically. Sulphur dioxide concentrations, for example, have improved by 95% since 1965; ozone levels have improved by 40% since 1975 and suspended particles have been reduced by 75% since 1965.

Toronto, like all large cities, occasionally experiences "smog" conditions but typically only on a small number of days each year. The ten-year average for annual "smog advisory" days (days when the Air Quality Index (AQI) is forecasted to exceed 50, thus reaching into the "poor" level) is 16.6, with those days typically spread over the months of May, June, July, August and September. In July 2008, downtown Toronto experienced only one day with an AQI reading above 50 (53 on July 16th). These readings

indicate that Toronto's air quality is better than most of its peer cities worldwide.

## SUSTAINABLE AND GREEN TORONTO

Toronto's commitment to environmentally friendly practices is evident in high-profile projects including the 30-storey wind turbine at Exhibition Place, the 47 downtown buildings (including Toronto City Hall) cooled by deep-lake water and the Metro Toronto Convention Centre hosting Canada's first zero-waste convention in 2007.

To make Toronto an even greener city, the city has set aggressive targets for reducing greenhouse gas emissions in the Toronto area - from 1990 levels the goal is to achieve a 6% reduction in emissions by 2012 and an 80% reduction by 2050. The City of Toronto has already reduced greenhouse gas emissions in its own operations by 30% since 1990. All of these initiatives fall within the city's "Climate Change, Clean Air and Sustainable Energy Action Plan" adopted by Toronto City Council in July 2007. The 2015 Pan American Games will be planned and executed within the standards of this plan.

The plan currently allocates significant resources to restoring and protecting the environment before 2015. Initial funding plans call for \$42 million to be spent on energy conservation, \$20 million on renewable energy and \$22 million on retrofitting City of Toronto facilities. These funding allocations represent only a small portion of Toronto's overall environmental effort.

Additionally, each newly-constructed facility for the 2015 Pan American Games will be LEED certified (Leadership in Energy and Environmental Design - an internationally-recognized rating system applied in more than 30 countries). The plan for the Games themselves - from energy management at the sport venues and Pan American Village, to waste management/recycling at all venues, to incorporating an innovative program of carbon-offsets - will be part of a "triple bottom line" evaluation which brings together environmental, economic and social analyses to determine not just the most cost-effective strategies, but the most responsible strategies.

## TORONTO REGION MICRO CLIMATES

The region that surrounds Toronto features a small number of micro climates that will have little, if any, influence on the Pan American Games plan.

The Niagara Escarpment runs from Niagara Falls (the Niagara River tumbles over the escarpment) to Tobermory, Ontario, a distance of 725 km. The escarpment is a UNESCO World Biosphere Reserve and its sharp altitude change creates a number of micro climates along its length, most notably in the Niagara Peninsula where the escarpment's protection against prevailing winds helps moderate the climate, making it an ideal zone for viticulture and wine-making.

The three Great Lakes closest to Games venues - Lake Ontario near the majority of the Games venues, along with Lake Erie and Lake Huron - have a moderating effect on temperatures in all seasons. This means that during the Games period in July 2015, it is unlikely that extreme heat will be a concern.

## ENVIRONMENTAL PROBLEMS AND NATURAL DISASTERS

Natural disasters in the Toronto region are extremely rare. While some parts of Canada are susceptible to extreme winter weather or possibly spring flooding, the July Games period (August for the Parapan American Games) in Toronto is one of the most accommodating times of year. The most likely adverse natural conditions at that time of year all relate to the possibility of weather conditions such as heat, humidity or thunderstorms.

Because Toronto is significantly inland from the nearest ocean (approximately 650 km in a straight line to the closest point on the Atlantic Ocean), the city is at little risk from violent weather such as hurricanes. The last hurricane to reach Toronto, for example, was hurricane Hazel in 1954. Seismic activity of any noticeable degree is exceedingly rare and inconsequential when it does occur.

In the unlikely event of a major natural disaster, however, all three levels of government have significant plans and resources in place for preparedness and response.



↑ TORONTO'S WATERFRONT  
PHOTO CREDIT: TOURISM TORONTO



↑ TORONTO'S CENTRE ISLAND  
PHOTO CREDIT: TOURISM TORONTO

## **SECTION HIGHLIGHTS:**

Athletes, coaches, officials and fans will be safe in Toronto. Rated by the Mercer survey as the best city for personal safety in the Western Hemisphere, Toronto will be welcoming and comfortable inside and outside the Games' secure areas. Using the latest technology and a comprehensive security plan coordinated by some of the world's best police and intelligence services, Toronto 2015 will ensure that all Games participants feel safe and secure.





# SECURITY

## A LOW-RISK GAMES

Canada offers a strong sense of personal safety and security to those who live, work and play in the country – residents and visitors alike. There is a general respect for law and order, a respect that is enhanced by professional and courteous police services. Crime rates are low and getting lower.

Toronto is rated by the Mercer survey on global livability as the best city for personal safety in the Western Hemisphere. Ontario has the lowest per-capita crime rate of any Canadian province.

The City of Toronto has hosted numerous international events involving hundreds of thousands of people – including the CONCACAF Women’s Soccer Championships, papal visits and World Youth Days – with great success and without incident. Similarly, Toronto and other cities in Canada have safely hosted major intergovernmental conferences and summits,

including the G8, G20 and the Summit of the Americas, with all of their attendant security requirements. The Ontario Provincial Police (OPP) and Royal Canadian Mounted Police (RCMP) are presently working in partnership to ensure the safe operation of the 2010 G8 Summit, to be held in Huntsville, Ontario, just north of Toronto. The security plans for Toronto 2015 will benefit from this experience, and from utilizing the best practices from the extensive security operations of the Vancouver 2010 Olympic Winter Games.

Canada’s is an open, cosmopolitan society with great respect for diverse cultures, religions and opinions. The right to peacefully dissent and protest is one of the hallmarks of Canadian democracy and is enshrined in the Canadian *Charter of Rights and Freedoms*. Toronto 2015 is strongly committed to ensuring that all Games venues will be accessible to participants, spectators, media, officials, staff and volunteers regardless of physical ability or the requirements of assistive devices or guide animals. Security procedures will also respect and exercise sensitivity for the diversity of cultures participating in the Games.

Canada is proud to be a low-risk society and Toronto 2015 will provide a low-risk Games.

At the same time, Toronto 2015 recognizes the security challenges that are so common in the Twenty-first Century and will be, therefore, prepared for all possibilities. The Games-time confidence about safety and security will come from intelligence, vigilance and coordinated planning among national, provincial and municipal public safety and security partners, working in cooperation with international agencies.

## SECURITY SERVICES

Security for the 2015 Games will be planned and operationalized by an integrated team involving all levels of policing, under a unified chain of command that employs state-of-the-art security and monitoring technology to protect Games venues, participants and spectators.

The Toronto 2015 commitment to security begins with the (OPP) which will lead an Integrated Security Team (IST) composed of municipal, provincial and federal security partners. The IST will assume overall responsibility for security planning and operations coordination, providing a single source of authority and direction for Games security.

## THE ONTARIO PROVINCIAL POLICE

- One of North America's largest deployed police forces with over 6,000 uniformed members, 2,600 civilian members and 850 auxiliary members
- Patrols 922,752 km<sup>2</sup> of land, 139,047 km of highways and 110,398 km<sup>2</sup> of waterways
- Mandate includes specialized investigative services, major case management, search and rescue, forensic identification, emergency response/assistance, anti-terrorism, intelligence and general law enforcement



↑ THE OPP IS THE SECURITY LEAD FOR THE PAN AMERICAN GAMES

As part of the 2015 IST, a Joint Intelligence Group (JIG) will be established well in advance of the Games. Comprised of RCMP, OPP, Toronto-area law enforcement agencies and other federal law enforcement and intelligence agencies, the JIG will work to proactively detect and prevent criminal activity, including acts of terrorism and violent or destructive activist behaviour.

During the Games, the OPP will lead a Unified Command Centre (UCC), which will coordinate security and provide command and control. The UCC will include municipal, provincial and federal security partner agencies. Security at each venue will be coordinated through a site command centre under the direction of a designated Incident Commander. The UCC

will serve as the primary link to the various venue command centres as well as provincial and federal operations centres.

Ontario boasts more than 30,000 highly-trained professional police and law enforcement personnel, approximately 1,000 of whom will likely be deployed on peak days during the 2015 Games. This professional force will be enhanced by 1,500 private security personnel and 2,000 security volunteers. Security resources will be drawn from a pool of trained police officers who will be assigned duties by their respective police services which include:

- Ontario Provincial Police
- Toronto Police Service
- Hamilton Police Service
- Durham Regional Police Service
- Halton Regional Police Service
- Peel Regional Police Service
- York Regional Police Service
- Niagara Regional Police Service
- Barrie Police Service

These agencies have the capacity and expertise to ensure the safe conduct of major international events and have an extensive history of working cooperatively during major events in the Toronto region, including international conferences, sporting events and cultural festivals. They also routinely and effectively combine resources to support tactical operations, joint intelligence operations, crowd management, criminal investigations, marine operations, search and rescue, and traffic management.

Utilizing a common Incident Management System (IMS), Ontario policing agencies work regularly and effectively with other emergency and public safety service providers including fire departments, Emergency Medical Services (EMS) and emergency management agencies. IMS provides a common planning and response structure, unified command and control, and harmonized inter-agency operations.

Private security resources will also assist in securing the Games by providing additional security where appropriate, including venue access screening and asset security. Private security agencies are subject to provincial regulations which ensure that only qualified, trained and bonded security personnel are employed in these capacities. Private security officers will work under the supervision of police personnel at a ratio commensurate with the specific task.

## INTELLIGENCE

### Royal Canadian Mounted Police

The RCMP has the legislated mandate for the protection of Internationally Protected Persons such as heads of state and for combating terrorism as defined in the *Security Offences Act*. In Ontario, the RCMP has responsibility for the Integrated National Security Enforcement Team and Integrated Border Enforcement Teams. These teams link directly with other intelligence agencies at the municipal, provincial, federal and international levels – including the Canadian Security Intelligence Service (CSIS) – providing for seamless border integrity, the early detection and prevention of terrorist acts, and the coordinated apprehension and prosecution of perpetrators.

### Canadian Forces

Canadian law clearly defines the ways in which the nation's armed forces may support domestic law enforcement operations. While not anticipated, resources of the Canadian Forces could be utilized if necessary to augment police and emergency services during the Games. Canadian Forces support could be in the form of personnel, facilities, equipment, transportation, as well as specific expertise in explosive, chemical, biological, and nuclear detection and disposal.

## GENERAL RISKS

### Intrusion into the Pan American Games Venues

Secure Games venues, from the sport venues to the Pan American Village, will be protected using concentric rings of physical and technological security to detect and prevent unauthorized entry of persons, vehicles, vessels, aircraft, weapons and substances. Each venue will be subject to an ongoing threat-risk assessment to allow for the application of appropriate security measures. Security measures may include physical barriers (fencing and barricades), physical surveillance, video surveillance, aerial surveillance, security patrols, physical searches of persons and vehicles, and magnetometer examinations.

The Games accreditation system will prevent unauthorized intrusions and ensuring that authorized only persons, including athletes, coaches, trainers, security personnel, emergency responders and media have expedited access to appropriate areas of the Pan American Games venues.

RCMP, OPP and Toronto-area police agencies have highly trained and equipped integrated tactical response resources. These resources include Incident Command, tactical response (containment, hostage rescue), hostage negotiation, canine, explosives disposal and CBRNE (chemical, biological, radiological, nuclear, explosives) units. Integrated tactical response resources will be strategically deployed within the Pan American Games theatre of operations to ensure rapid response in support of venue security personnel should the need arise.

### Civil Disobedience

Canadians are proud of the *Charter of Rights and Freedoms* which protects the rights of individuals and allows for lawful expressions of dissent.

All police services with responsibility for Toronto 2015 security have significant public order maintenance capability. All Ontario police agencies with Public Order Unit (POU) capability are represented on the Ontario Public Order Advisory Committee. This standing committee works to ensure consistency in the development and application of public order policy, training and equipment. This ensures effective integration during public order operations.

RCMP, OPP and Toronto area police agencies have significant experience in conducting integrated public order operations and are often sought out to provide support to other law enforcement agencies both provincially and nationally. These units pride themselves on their highly professional, coordinated and measured response to acts of civil disobedience.

OPP Provincial Liaison Teams are comprised of police personnel with specific training in dispute resolution, mediation and negotiation. These teams are deployed well in advance of major events to work cooperatively with stakeholders at all levels, including the activist community, with a goal of satisfying mutual interests, including the facilitation of lawful protests. An integrated liaison team will be established well in advance of the 2015 Pan American Games for this purpose.

### Terrorism

Since the September 11, 2001 terrorist attacks in the United States, Canada and Ontario have taken significant measures to strengthen policing, security and intelligence services. These enhancements include additional intelligence and investigative personnel, response teams and detection equipment, and enhanced counter-terrorism plans and procedures.

Security resources at border crossings and other points of access have been increased and are continually being refined and updated. There have also been substantial enhancements to the security of critical infrastructure including transportation systems, telecommunications and information technology systems, energy supplies, food and water supplies, and nuclear power generating facilities.



↑ ROYAL CANADIAN MOUNTED POLICE (RCMP)

## **SECTION HIGHLIGHTS:**

Toronto has a proven ability to meet the health care needs of high-profile events involving large numbers of international visitors. For Toronto 2015, the PASO family will have access to Canada's trusted health care system along with health insurance provided specifically for the Games. As the home of the World Anti-Doping Agency, Canada's main anti-doping laboratory is one of the world's most experienced and highly-regarded.





# MEDICAL SERVICES

## WORLD-CLASS HEALTH CARE AND EMERGENCY HEALTH MANAGEMENT

Canada is proud of its universal health care system – better known as Medicare – which provides insured, medically-necessary services to all Canadian residents. The World Health Organization’s *World Health Report* ranked Canada’s health care system 7th (tied with Norway) for “responsiveness” among the 191 nations reviewed. Canada was also ranked 7th for “overall health system attainment.”

For the 2015 Pan American Games, Canada’s health care system, along with specific services and enhancements put in place by Toronto 2015 for the benefit of the Pan American family and visiting spectators is a paramount concern. Host medical services will be available at all Games venues, providing both first-response and sport medicine capabilities. The Pan American Village will feature an advanced Polyclinic that offers service in both general and sport medicine, inter-professional medical care and rehabilitation services. Each of these points of care will be fully integrated and connected to the larger system of health care in Ontario, ensuring swift and comprehensive response to the health care needs of all accredited members of the PASO family.

## HEALTH CARE SYSTEM

The health care system in Ontario is comprised of emergency and elective services for acute, chronic and rehabilitative needs, along with primary care through a vast network of family doctors, ambulatory clinics and professional services which include physiotherapists, dentists, dieticians, chiropractors, nurses in supportive capacities and numerous other health care professionals. Ontario has 211 hospitals, with more than 40 of those hospitals and 18,369 beds in the Toronto region.

Communicable disease morbidity and mortality in the Canadian population is minimized through prevention, control and monitoring programs. Immunization is mandatory for school-aged children resulting in almost 100% coverage rates.

Canada’s standards of hygiene are among the highest in the world. Toronto’s drinking water system supplies 2.7 million city residents and is tested every four hours to maintain quality. Similarly, the provincial government maintains high standards of food safety and sets the province-wide standards for drinking water provision and waste water management.

## MEDICAL SUPPORT AT THE GAMES

Medical services specifically for athletes and team officials will be available during the Games at each sport venue as well as through the Polyclinic located at the Pan American Village. Host medical staff will be prepared to provide care directly to those Games participants who do not have accompanying medical staff and to facilitate and assist the provision of care by visiting medical professionals treating members of their own delegations.

Games venues will feature host medical services provided by physicians, sport therapists and paramedics with active clinical licenses who are trained in emergency management. Depending on the severity of the medical situation, patients may be relocated to the most appropriate hospital. The Pan American Village Polyclinic will provide full service inter-professional medical care and will be staffed 24 hours a day.

## PAN AMERICAN VILLAGE POLYCLINIC

The Polyclinic will be located within the Residential Zone of the Pan American Village. This state-of-the-art facility will be secured by electronic card access and reserved for the use of accredited athletes, team officials and medical personnel.

### HEALTH INSURANCE PLAN FOR THE PAN AMERICAN FAMILY

Toronto 2015 will provide a health insurance plan for all members of the PASO family to cover the costs of medical and dental care, including:

- Medical assistance at the Village Polyclinic (for bearers of accreditation to the Village Residential Zone)
- Medical assistance in any of the reference hospitals (including emergency surgical procedures and intensive care)
- Medical assistance in the Games venues
- Treatment and tests in specialized clinics (when not offered at the Polyclinic)
- Urgent and necessary dental care, and
- Medications

The Polyclinic will be staffed 24 hours a day. A team of sport medicine professionals will be available throughout different times of the day to meet all residents' needs. These professionals will include general and sport medicine physicians, physical therapists, nurses, massage therapists, laboratory technicians, dentists and chiropractors.

The Polyclinic will feature easy access for ambulances and a short 3 km trip by road to the nearest hospital, St. Michael's Hospital, a major teaching and research facility which is one of the designated trauma centres for downtown Toronto. Just 2 km farther, there is an additional cluster of university-affiliated hospitals ready to provide secondary assistance if required, or as particular specialities dictate. These hospitals include the Toronto Rehabilitation Institute, Mount

Sinai Hospital, Women's College Hospital, the Hospital for Sick Children, and the University Health Network's Toronto General Hospital, Toronto Western Hospital and Princess Margaret Hospital.

## FIRST AID

On-site first aid services for spectators and volunteers will be available at each Games venue. These qualified first responders will be able to provide first aid services within their scope of practice. If necessary, the host medical team may provide additional assistance. Members of the public have access to any hospital emergency room in Ontario.

## EMERGENCY MEDICAL SERVICES

Ontario and Toronto have high quality, responsive, integrated and comprehensive emergency health services systems providing highly-coordinated air and land ambulance services that are directed through a network of Central Ambulance Communications Centres.

This system has demonstrated its ability to manage the demands of large events including two papal visits (450,000+ people), cultural festivals like Caribana (one million+ people), music festivals such as the 2003 Molson Canadian Rocks Benefit Concert (350,000+ people) and G7 and G8 Summits while maintaining and protecting the flow of patients to and from the network of community, regional and specialty-care hospitals across the province.

Ontario's ambulance/paramedic system will have vehicles stationed at each Pan American Games venue, with larger venues having multiple vehicles present during peak times. Ambulances will travel on the designated travel corridors from venues or the Pan American Village to designated hospitals. If required, helicopter air ambulances will be dispatched.

The provincial emergency response program consists of a series of Memorandums of Understanding between the Province of Ontario and nine municipalities for response on a 24-hour basis to large-scale emergencies, particularly those involving chemical, biological, radiological, nuclear or explosives-related causes (CBRNE) or structural collapses (Heavy Urban Search and Rescue – HUSAR).



EMERGENCY MEDICAL SERVICES  
PHOTO CREDIT: CITY OF TORONTO EMERGENCY SERVICES

### TORONTO REGION'S EMERGENCY RESPONSE CAPACITY

- 3,000 front-line staff trained in emergency medical response
- 350 ambulance vehicles with more than 2,000 paramedical staff
- 450 fire trucks and rescue units
- 5,500 full-time firefighters
- 4 emergency helicopters on stand-by, with 6 available during the Games

### DOPING CONTROL

Canada is a world leader in doping control and a founding member (and the current home) of the World Anti-Doping Agency (WADA). The Canadian Centre for Ethics in Sport (CCES) is a signatory to the World Anti-Doping Code, and operates a WADA compliant Anti-Doping Program throughout Canada. CCES is one of the most experienced anti-doping agencies in the world, having conducted thousands of doping tests since 2000.

The Toronto 2015 doping control program will follow all PASO, IOC and WADA regulations and guidelines, even as they evolve up to 2015.

Toronto 2015 will operate its doping control program under the auspices of the CCES, which will ensure all policies and procedures will meet with expected international standards in the year 2015. All athletes will be tested at each sport venue. Each sport venue will house a secure doping control station that will be staffed by certified doping control officers and trained volunteers.

All doping control samples collected at the Games will be analyzed at the University of Quebec's Institute National de la Recherche Scientifique (INRS) – Institut Armand-Frappier in Montreal. The INRS is a WADA-accredited laboratory, in compliance with the WADA International Standard for Laboratories (ISL). It performs sample analyses on an ongoing basis for Canada's domestic anti-doping program. The laboratory is also ISO 9001: 2000 certified, and has a track record of having conducted anti-doping analyses for many international multi-sport games, international single-sport



WADA ACCREDITED LABORATORY FOR THE 2015 PAN AMERICAN GAMES  
PHOTO CREDIT: INRS - INSTITUT ARMAND-FRAPPIER

events and high performance leagues. The laboratory performed all sample analyses for the 1976 Olympic Summer Games (Montreal), the 1980 Olympic Winter Games (Lake Placid), the 1988 Olympic Winter Games (Calgary), the 1994 Commonwealth Games (Victoria), the 1999 Pan American Games (Winnipeg) and the 2003 Pan American Games (Santo Domingo). This laboratory will be used for the Vancouver 2010 Olympic Winter Games.

The INRS lab will provide daily analyses of urine and/or blood samples as required. All samples will be accompanied in transit by a special courier. Sample testing will be conducted using state-of-the-art technologies, including high resolution mass spectrometry, gas chromatography and other state-of-the-art analytic methods available currently (or that may be developed by 2015), in accordance with the ISL.

### EXCELLENCE IN DOPING CONTROL

The Canadian Centre for Ethics in Sport (CCES) administers doping control in Canada as prescribed in the International Anti-Doping Arrangement's International Standard for Doping Control.

The INRS – Institut Armand-Frappier lab is compliant with the WADA International Standard for Laboratories (ISL). It is also ISO 9001: 2000 certified and was one of the first anti-doping labs to achieve this designation.

## **SECTION HIGHLIGHTS:**

Toronto's newly built, Pan American Village will offer up to 8,500 dedicated beds and be one of the jewels of the Games legacy. Located within close proximity to Toronto's picturesque waterfront, iconic downtown and several major Games venues, the Village will incorporate an 18-acre park with a range of training facilities including a 50m pool, 400m track and running trails. The International Olympic Committee's technical requirements will be met at the Toronto 2015 Pan American Village.





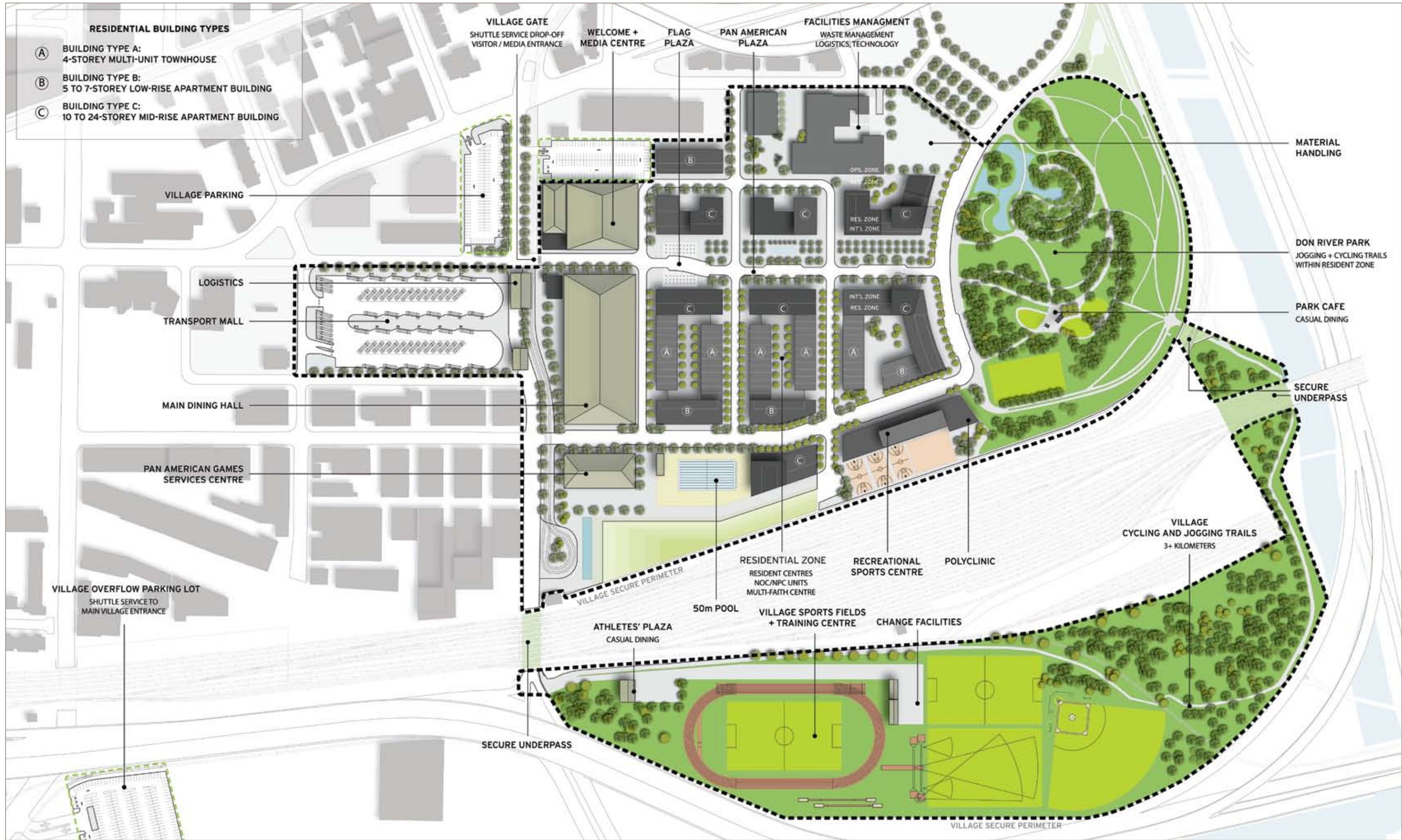

# PAN AMERICAN VILLAGE

The revitalization of the Village site is already underway and will proceed regardless of the outcome of the Pan American Games bid.

## A NEW VILLAGE - A NEW NEIGHBOURHOOD

The site of the Pan American Village is uniquely positioned to accommodate both the needs of the Toronto 2015 Pan American Games and the vision for a powerful post-Games legacy. Located in Toronto's waterfront district – just east of downtown, within 25 minutes of most Games venues and less than 25 minutes from

the airport – the Pan American Village will be one of the jewels of the Toronto 2015 Games legacy.

Over the past several years, the site of the Village has been the subject of extensive visioning and planning work, the result of which is an award-winning plan for waterfront redevelopment that is flexible, sustainable and integrated into the fabric of the city. It will result in a vibrant new showcase neighbourhood that will knit into the surrounding urban communities and become a model for urban revitalization and sustainability.

Construction of supporting infrastructure and the acquisition of planning approvals are already well underway, ensuring that the Toronto 2015 Pan American Village will meet the strict timelines demanded by the Games. The 80-acre provincially-owned site will accommodate a flexible mix of housing, office space, retail/restaurants and staging areas, all just a few minutes' walk to Toronto's picturesque waterfront.

The Pan American Village, which will incorporate an 18-acre park, will be immediately adjacent to the Don River and the landscaped boulevard of Front Street. The residences will incorporate a mix of housing types from townhouses to mid-rise buildings and towers. At the heart of the Pan American Village, a wide boulevard/piazza will function as the natural gathering place for events and social activity.

## THE VISION FOR THE PAN AMERICAN VILLAGE

The vision for the Toronto 2015 Pan American Village will put a newly-constructed, self-contained, high-capacity Village in the heart of the Games. It will provide a quiet, safe and secure Games-time home of Olympic standard for up to 8,500 athletes and team officials. It will incorporate a full range of conveniences and amenities while also offering easy transportation to Games venues and close proximity to the attractions of the adjacent downtown and waterfront. It will be a safe and welcoming environment, secured by the latest technology and supported by a cohort of well-trained staff focused on meeting the needs of the residents.

The Toronto 2015 Pan American Village will be an exceptional fit for the requirements of the Games and also a wonderful legacy for the City of Toronto.

The Pan American Village will feature buildings that will meet LEED (Leadership in Energy and Environmental Design). The overall Village design will also be an excellent candidate for participation in the LEED ND (Neighbourhood Design) program which looks beyond energy-efficient buildings to community-scale characteristics such as development density and proximity, walkable streets, affordability, community involvement and diverse local uses.

## TORONTO 2015 PAN AMERICAN VILLAGE HIGHLIGHTS

New Village Development	Able to offer a high standard of hospitality, service and technology
Meets or Exceeds IOC Technical Requirements	Examples include air conditioning, single occupancy living quarters rooms at 9m <sup>2</sup> and double occupancy at 12m <sup>2</sup> , up to 8,500 beds and spacious NOC offices
Secure Park within Village Perimeter	Large 18-acre park within the secured Village perimeter, including running and cycling trails
New Training and Recreation Facilities	400m athletics track and field for training, a 50m pool, and a recreation/fitness centre all within the Village site
Large and Efficient Transport Mall	Central depot to serve as an efficient entry/exit point for athletes and team officials – will also be the hub for internal Village transportation
Comprehensive Services	24-hour services throughout the Village, including but not limited to transportation, dining, sport and recreation
Compact Village Layout	All core services are within 5 minute walk of all residence buildings
Central Location	Easy access to major transportation arteries and close proximity to Toronto's attractions and Games venues
Sustainable Green Technology	LEED certified buildings and neighbourhood featuring a district energy system for efficient heating and cooling
Significant Post-Games Legacy	Housing development and new city neighbourhood on a previously underutilized site, along with new sport facilities for community use

## ATHLETE-CENTRED

Toronto 2015 will take an athlete-centred approach to planning and operating the Pan American Village. This will translate into designs, policies and practices that are specifically required to respect the traditions, cultures, abilities, languages and cuisines of all residents. The Pan American Village will also provide a secure, comfortable and highly-functional environment that allows the athletes to focus on enjoying their Games experience and competing to the best of their abilities.

## DATES OF OPERATION

The Pan American Village will open at least 10 days before the first day of the Games and close no earlier than 3 days after the Closing Ceremony, in accordance with PASO regulations.

The minimum operational dates of the Pan American Village will be: Tuesday, June 30, 2015 to Wednesday, July 29, 2015.

## VILLAGE COMPONENTS

### Welcome Centre / Accreditation Centre

The Welcome and Accreditation Centre will greet the arriving teams. This area will offer a selection of hospitality services (including baggage and equipment handling) and present a distinctive décor representing both Canadian culture and the history of the Pan American Games.

The high-volume accreditation desk will process the arriving teams efficiently to ensure that all residents receive their accreditation in a timely manner. Team arrival processing will take place in the same location.

### Residential Zone

The Residential Zone of the Pan American Village is a highly restricted area with accommodations and services for up to 8,500 residents. The Residential Zone will also provide spacious and furnished offices for NOC's, large main dining facilities with diverse and healthy menu options, casual dining areas and a Polyclinic offering the highest standard of care. There will be spaces for worship and quiet contemplation, social and leisure areas, along with sport and recreational areas for on-site training and fitness needs. More specifically, the Residential Zone will include:

- Resident accommodation in secure rooms
- Residents' Dining Hall (24-hour hot meal service, spacious seating area, diverse menu with ingredients identified) standards



↑ RESIDENTIAL ZONE

- Casual Dining Hall (alternative menu options offered)
- NOC office and meeting space (includes work space, medical room)
- NOC secure storage space
- NOC Services Centre
- Bookable meeting rooms
- Polyclinic (emergency care, outpatient area, rehabilitation area and equipment, pharmacy, medical imaging, laboratory services)
- Village Communications Centre
- Sports Information Centre
- Chefs de Mission Hall
- Sports Viewing Room
- Entertainment
- Resident Services Desk
- Religious Centre
- Security Command Centre
- Laundry facilities (multiple locations)

The Residential Zone will also offer the residents secure access to a selection of training and recreation facilities. A recreation centre, 50m pool, 400m track, throwing and jumping area, basketball courts and a football pitch will all be part of the zone. These features will be connected to the 18-acre Don River Park which will also be part of the Residential Zone. The park will offer running and cycling trails that wind through an urban meadow with views of the Don River, Lake Ontario and downtown Toronto.

The Residential Zone, in fact the entire Pan American Village, will be equipped for wireless access for personal computers and handheld devices.

#### ENHANCED RATE CARD

Toronto 2015 will provide PASO and all NOC's with an "enhanced" rate card system. The rate cards will ensure that members of the PASO family have a convenient system for obtaining the services and resources they require in Toronto. The rates will be negotiated in advance to ensure the best prices possible.

#### International Zone

The International Zone, which is restricted to residents except between 9:00 am and 9:00 pm when guests may obtain passes, is the heart of the Pan American Village and is the primary place where athletes, officials, guests and media can interact. It will be the meeting place for residents and guests, the location of a retail/commercial area and will provide spaces suitable for media interviews. This zone will incorporate the media sub-centre, guest dining facilities, banking facilities, a general store, a retail outlet, recreation and leisure facilities and a telecommunications facility. Many of the services in this zone will be staffed 24 hours a day. More specifically, these services include:

- Outdoor / Tented Stage (site for the Team Welcome Ceremonies)
- General Store (includes pharmacy, florist, dry cleaner, post office)
- Bank
- Communications Café (internet access, telephones)
- Hair Salon
- Café
- Travel Agent
- Ticket Office
- Information Desk
- First Aid Station



Toronto 2015 will also establish a Pan American Games Pavilion that celebrates the best of sport, culture, innovation and social leadership from the Caribbean and the Americas.

### Operations Zone

The Operations Zone will be the centre of support for the Pan American Village. This zone will feature a transportation mall, site management offices, storage, materials transfer areas, waste management areas, laundry and other back-of-house areas.

- Welcome Centre / Accreditation Centre (access control point)
- Visitor Centre (access control point)
- Village Media Centre
- Transport Mall
- Dedicated Vehicle Parking with reserved parking for NOC officials

- Village Vehicle Pool (motor pool, bicycle pool, cart pool)
- Facilities Services Centre
- Village Management Office
- Staff Centre
- Housekeeping/Laundry

The Pan American Village General Manager (GM) will be an experienced and senior member of the Toronto 2015 staff. With this in mind, Toronto 2015 will draw on Canada's international games hosting experience, including the Winnipeg 1999 Pan American Games and Vancouver 2010 Olympic Winter Games, to ensure that the GM has direct experience in managing a village in a multi-sport games environment.

### Transport Mall

The transport mall will be the hub of all dedicated transportation to, from and within the Pan American Village. Like the entire Village, the mall will feature easy-to-follow signage, in Spanish, English, French and Portuguese, and frequently-scheduled bus and shuttle transportation to ensure Village residents are able to travel among the Games venues in a timely and carefree fashion.

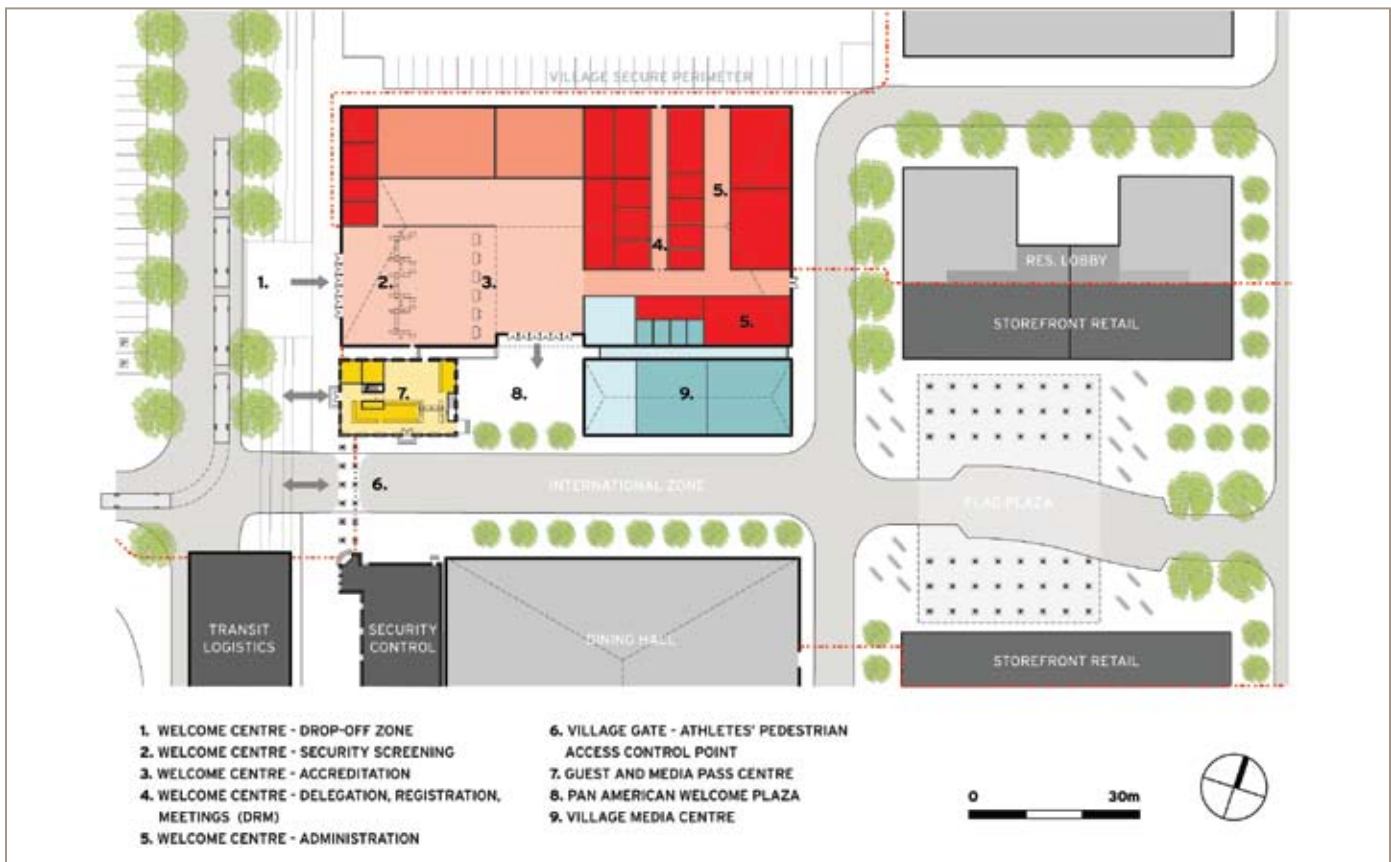
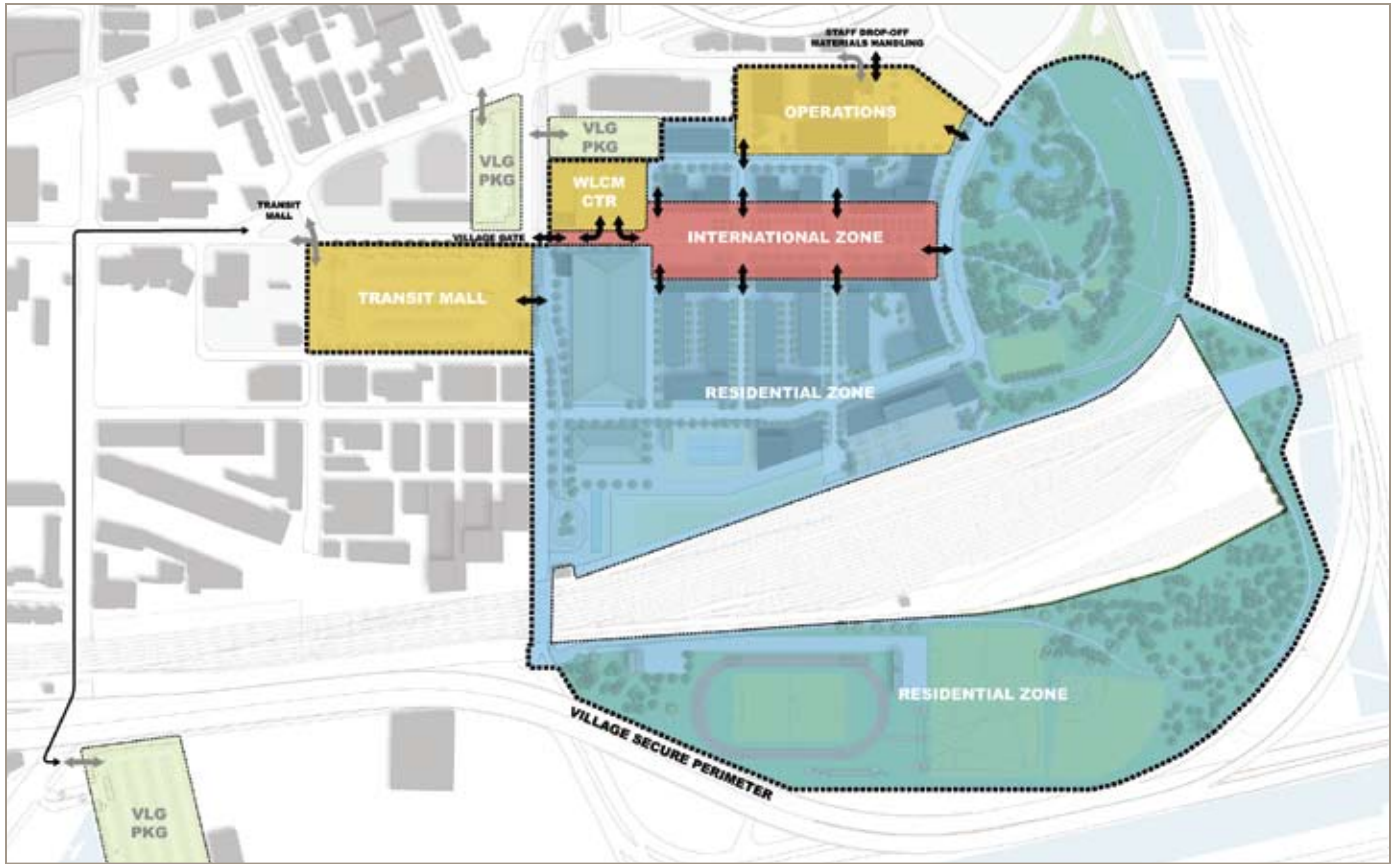

↑ VILLAGE SITE PLAN AND WELCOME CENTRE

**BUILDING TYPE A:  
NOC TOWNHOUSE UNIT TYPICAL PLAN**

0 5m

DELEGATION UNIT  
TOTAL AREA 96.29 m<sup>2</sup>

ROOM No.		SURFACE AREA
01	C. de M. QUARTERS	13.25 m <sup>2</sup>
02	C. de M. OFFICE	1200 m <sup>2</sup>
03	MEETING ROOM	12.15 m <sup>2</sup>
04	MASSAGE ROOM	6.05 m <sup>2</sup>
05	TEAM OFFICE	13.50 m <sup>2</sup>

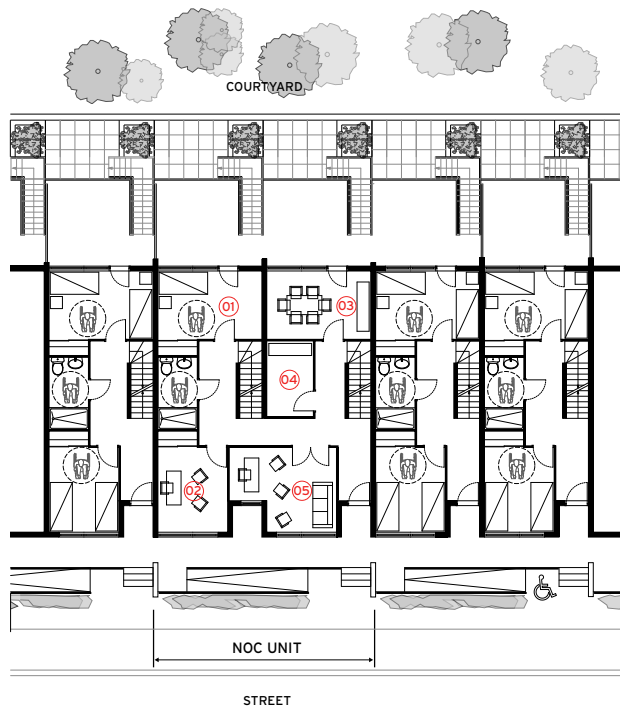

**BUILDING TYPE A:  
ATHLETES' TOWNHOUSE UNIT  
TYPICAL PLAN + SECTION**

0 5m

12 PERSON UNIT  
TOTAL AREA 196.00 m<sup>2</sup>

ROOM No.		SURFACE AREA
01	BEDROOM	13.85 m <sup>2</sup>
02	LIVING	13.65 m <sup>2</sup>
03	BEDROOM	15.05 m <sup>2</sup>
04	BEDROOM	12.15 m <sup>2</sup>
05	BEDROOM	12.05 m <sup>2</sup>
06	BEDROOM	13.60 m <sup>2</sup>
07	BEDROOM	15.70 m <sup>2</sup>

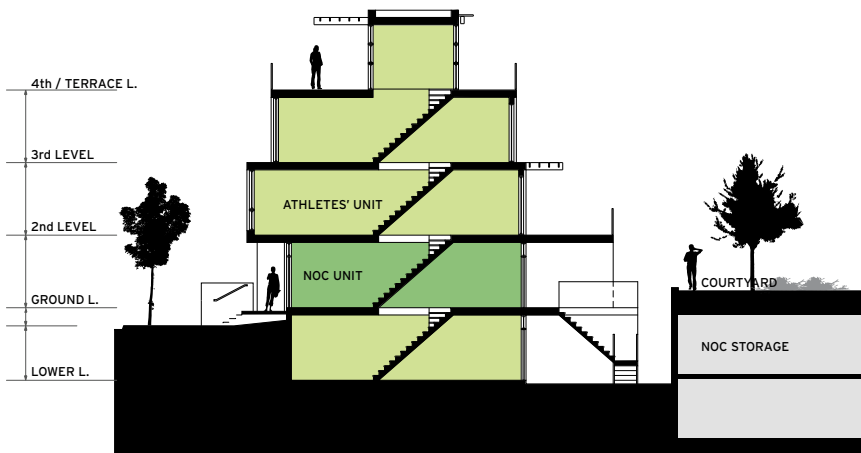
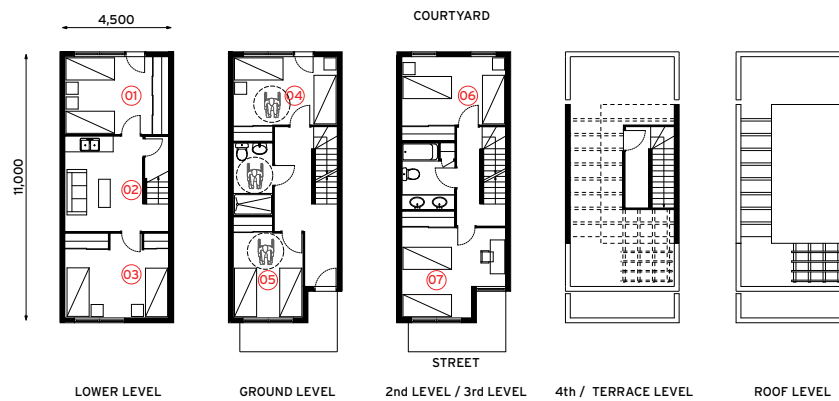

↑ BUILDING TYPE A



↑ VILLAGE AERIAL VIEW

**BUILDING TYPE B:  
NOC APARTMENT TYPICAL PLAN**

0 5m

ROOM No.	SURFACE AREA
01	C. de M. OFFICE 13.36 sm
02	C. de M. QUARTERS 11.65 sm
03	DOCTOR'S QUARTERS 12.00 sm
04	MEETING ROOM 23.16 sm
05	DOCTOR'S OFFICE 11.65 sm
06	MASSAGE ROOM 11.36 sm
07	MASSAGE ROOM 11.36 sm
08	MASSAGE ROOM 12.90 sm
09	TEAM OFFICE 13.12 sm
10	DOCTOR'S ROOM 12.90 sm
11	DOCTOR'S ROOM 12.90 sm

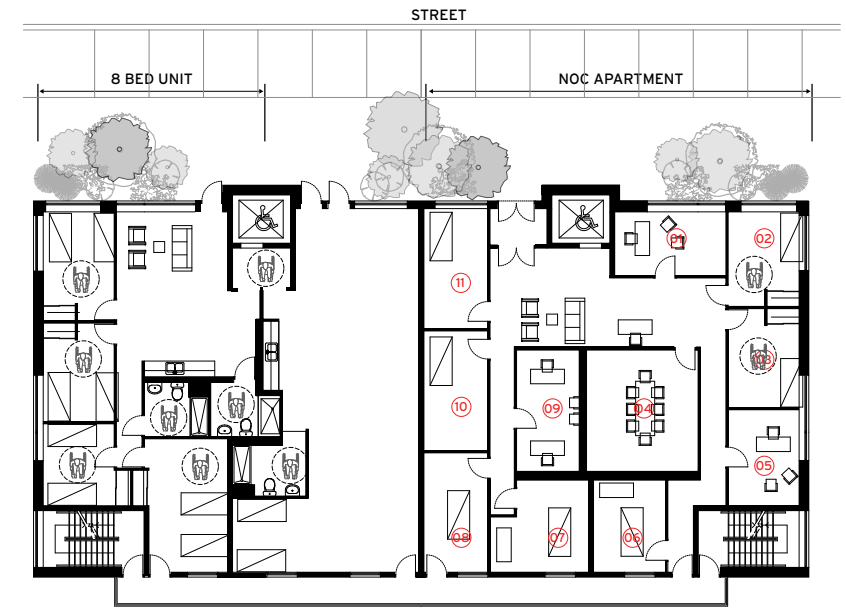

**BUILDING TYPE B:  
ATHLETES' APARTMENT TYPICAL PLAN + SECTION**

0 5m

ROOM No.	SURFACE AREA
02	BEDROOM 13.25 sm
03	BEDROOM 12.10 sm
04	BEDROOM 12.00 sm
05	BEDROOM 18.35 sm

ROOM No.	SURFACE AREA
01	BEDROOM 13.90 sm
02	BEDROOM 14.15 sm
03	BEDROOM 14.15 sm

ROOM No.	SURFACE AREA
01	BEDROOM 14.60 sm
02	BEDROOM 13.25 sm
03	BEDROOM 12.10 sm
04	BEDROOM 12.00 sm
05	BEDROOM 18.35 sm

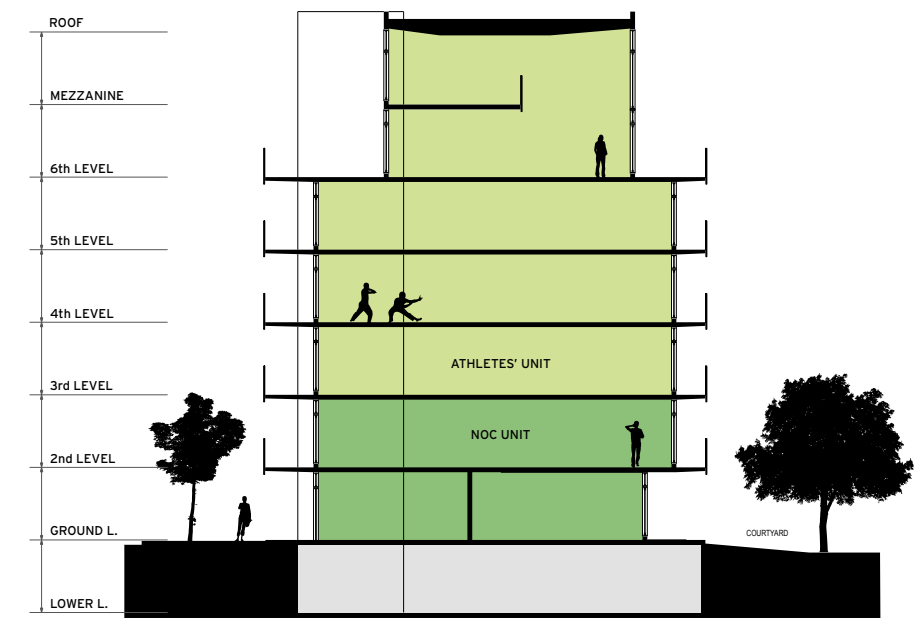
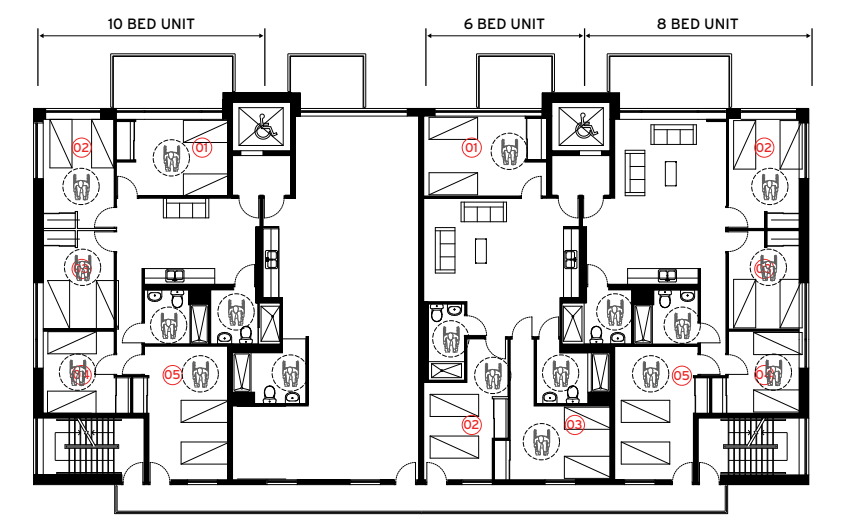

↑ BUILDING TYPE B

**BUILDING TYPE C:  
ATHLETES' GARDEN APARTMENTS TYPICAL PLAN + SECTION**

0 5m

ROOM No.	SURFACE AREA
01	BEDROOM 12.15 m <sup>2</sup>
02	LIVING 12.60 m <sup>2</sup>

ROOM No.	SURFACE AREA
01	BEDROOM 12.15 m <sup>2</sup>
02	LIVING 15.00 m <sup>2</sup>

ROOM No.	SURFACE AREA
01	BEDROOM 12.15 m <sup>2</sup>
02	LIVING 6.30 m <sup>2</sup>



↑ BUILDING TYPE C





INTERNATIONAL ZONE

Transfers between the Pan American Village and the Games venues will be quick, with multiple routing options, each capitalizing on the convenience of dedicated Pan American lanes for road transportation. The majority of Games venues will be no more than 25 minutes from the Pan American Village.

#### THE VILLAGE LEGACY

The Pan American Village will create a new community on Toronto's waterfront, a community that is economically, socially and environmentally sustainable. It will address a number of public policy objectives, including the reduction of urban sprawl, creation of new affordable housing and community sports facilities, enhanced access to public transit and reduction of the environmental impact of development.

#### VILLAGE ACCESS PLAN

Transportation will be available 24 hours a day on quiet, clean and energy-efficient shuttles traveling throughout the Village. Transportation will also be available to and from sport venues, the locations of Games cultural activities and key locations throughout Toronto. Numerous pedestrian pathways and bicycle paths will connect areas within the Pan American Village.

While access into the Pan American Village will be strictly controlled through a limited number

of access points, the location of the Pan American Village itself is accessible via a number of transportation options including local roads (which will feature dedicated Pan American lanes beginning at the entrance/exit of the Village), highways, express trains and public transit.

#### SECURITY

The site of the Pan American Village will be a significant asset in securing the Village because the site can be effectively secured for the Games while maintaining a spacious and open feel for the athletes. Access routes surrounding the Village can be controlled or closed during the Games with minimal disruption to local communities. The Don River to the east and the rail corridor to the south create a natural perimeter that can be effectively secured. This will simplify the process of controlling access to the Pan American Village during the Games.

Under the leadership of the Ontario Provincial Police (OPP), the policing agency that will provide central control to all Games security measures, the Pan American Village will also utilize state-of-the-art security technology to create a safe environment for all residents and visitors.

#### VILLAGE CULTURAL AND RECREATIONAL PROGRAMS

Beginning with the Welcome Ceremony to mark each team's arrival at the Village, the Pan American Village will be the home of, and the starting point for, a wide range of cultural and recreational experiences. Residents will have the option of spending time in relaxing, lounge-like social settings or taking part in the nightly entertainment planned specifically for the residents of the Village. Athletes will also have dedicated transportation to, and seating at, the nightly celebrations scheduled for various locations throughout the city. Beyond the Games-specific entertainment options, athletes and their families will have access, through the Village Ticket Office, to a diverse range of cultural activities including the attractions of downtown Toronto and trips to legendary Niagara Falls where Toronto 2015 will have a Pan American-specific welcome centre to arrange guides, tours and tickets for members of the PASO family.

## DESIGN EXCELLENCE

The Pan American Village will not simply be a routine collection of average buildings. The Village will feature the type of excellence in design that turns a place to stay into a home-away-from-home. This includes a fully accessible and barrier-free environment for Village residents.

A panel of Canada's leading architects, landscape designers, engineers and academics has provided advice and guidance in selecting

and directing the designers involved in planning the overall waterfront development project of which the Pan American Village is an important element. This design review panel vets all buildings, parks and public realm projects to be constructed on the waterfront.

These efforts have already been recognized with awards such as the 2007 Toronto Urban Design Award and the 2008 Royal Architectural Institute of Canada's Sustainable Development Award.

## SUSTAINABLE DESIGN

All buildings in the Pan American Village will be built to achieve LEED (Leadership in Energy and Environmental Design) Gold certification, and will rely on a district heating and cooling system to ensure efficient energy delivery. The design of the Pan American Village will make the project an excellent candidate for participation in the US Green Building Council LEED ND (Neighbourhood Design) program which takes community-scale characteristics such as development density and proximity, walkable streets, affordability, community involvement and diverse local uses into account.

## CONSTRUCTION

The extensive work completed to date on the Pan American Village site, including obtaining planning approvals, infrastructure construction and public realm design, helps ensure that the Pan American Village will be ready for the Games. Operational planning and infrastructure construction are already progressing, thus enhancing Village construction readiness.

### SECURE INFRASTRUCTURE BUDGET

Funding for all parks and municipal infrastructure required as part of the design of the Pan American Village is already in place as part of a broader \$1.5 billion commitment that supports projects across Toronto's entire waterfront. This funding comes from all three levels of government - federal, provincial and municipal.



↑ RECREATION CENTRE - RESIDENTIAL ZONE



↑ INTERNATIONAL ZONE

## FINANCING AND SCHEDULE

The internationally recognized Toronto waterfront planned community has an estimated investment valued at approximately \$1 billion (Cdn).

The Pan American Village will be located in this remarkable and visionary development. After the games, the Village is expected to become a new community of high quality affordable housing and the prospect of market units as planned for the West Don Lands.

The West Don Lands is a publicly-led development that will proceed regardless of whether Toronto is selected as the host city for the 2015 Pan American Games. The proposed site of the Village – owned by the Province of Ontario – represents a prime development opportunity along Toronto's waterfront.

The incremental costs for the Village are estimated to be approximately \$100 million. This includes funding for temporary facilities in the Village during the Games and the cost to convert the residential units used by the athletes for permanent occupancy after the Games.

Toronto 2015 will work with all partners in the design and construction of the Village to ensure compliance with all Pan American Games Village requirements.

The development of the site where the Pan American Village will be located has begun, with some infrastructure already in place.

# CONSTRUCTION SCHEDULE

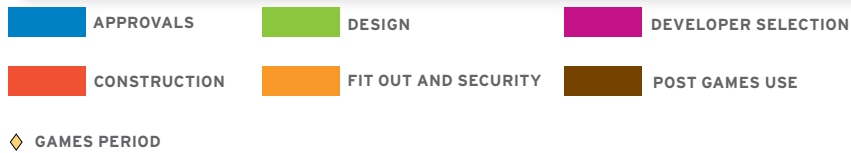
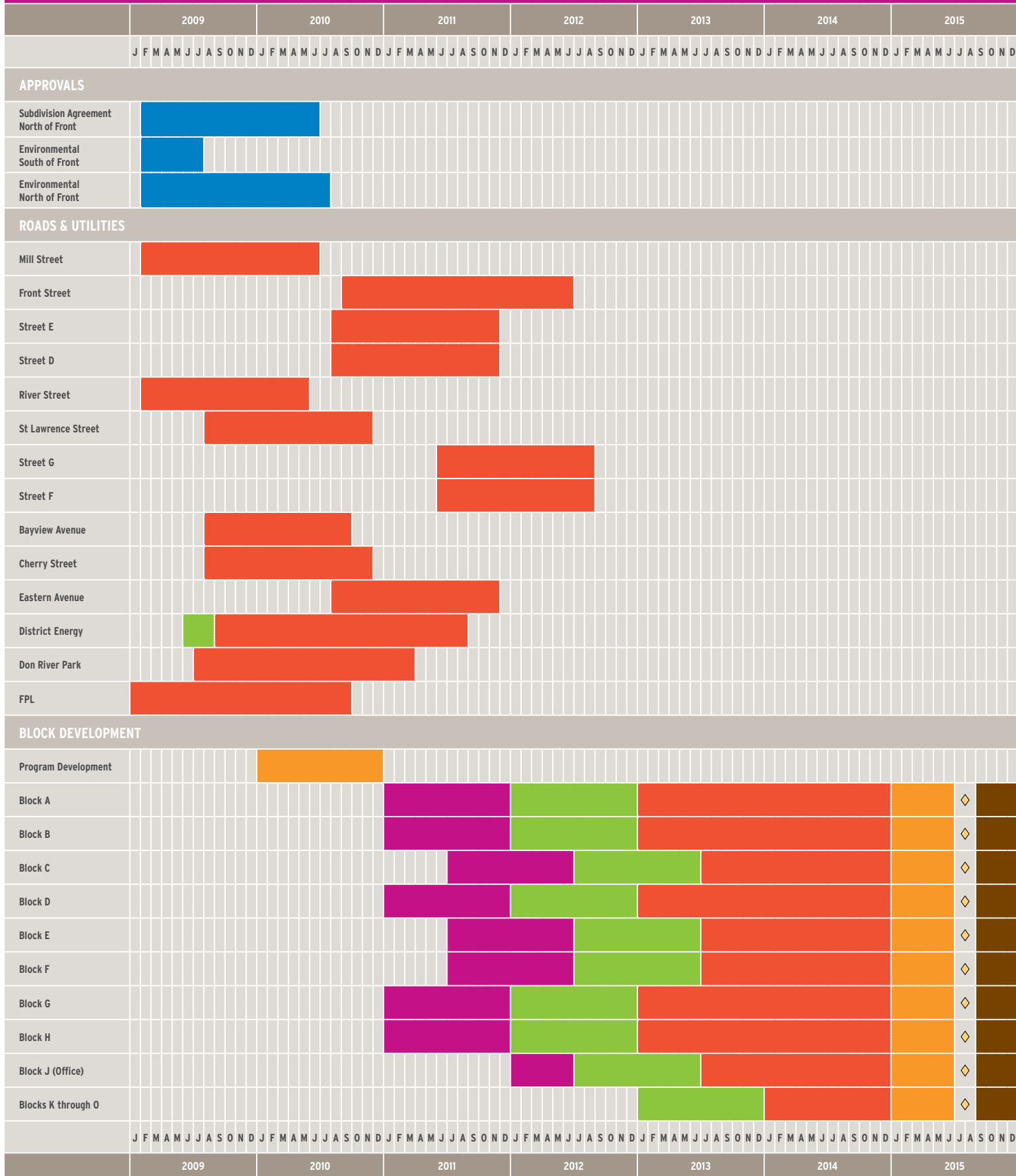



PAN AMERICAN VILLAGE SITE - 1999



CONSTRUCTION AT PAN AMERICAN VILLAGE SITE - 2009



PAN AMERICAN VILLAGE - 2015

## **SECTION HIGHLIGHTS:**

The Toronto region welcomes 20 million visitors every year, so the inventory of accommodations – from inexpensive to lavish – is large, diverse and ready to host PASO family, officials, sponsors, media and fans. The Host Hotel – the Fairmont Royal York – is one of the world’s iconic hotels and exceeds PASO host hotel requirements on all criteria while combining a prime location, the latest amenities and a sense of historic grandeur.





# ACCOMMODATIONS

## MAXIMUM HOTEL RATE FORMULA

To keep the cost of accommodation in line with normal market forces during the Games, Toronto hotels have agreed to set 2015 Games-time rates within an upper limit calculated by using a baseline of 2009 room rates, increased annually by an inflation rate of no more than 3%. This will ensure that there is no sudden inflation of accommodation costs for the Games period.

## WORLD-CLASS HOSPITALITY

The Toronto region welcomes 20 million visitors a year. As a result, the city and the region are experienced hosts and offer the quantity and quality of accommodation options needed for the 2015 Pan American Games.

Accommodations available in and around Toronto offer something for everyone in the PASO family. A large number of hotels are located close to the Games venues, providing a variety of prices and service levels, ranging from the simple and inexpensive to establishments that have hosted international dignitaries and heads-of-state.

## HOTEL CAPACITY IN THE TORONTO REGION

With over 55,000 guestrooms in the Toronto region and approximately 235 hotels and residences, the Toronto region's thriving hospitality industry has the capacity to host 40 million guests a year based on double occupancy.

Hotels within the City of Toronto itself have committed 22,971 rooms per night for the peak Games period in 2015. Finding a hotel room will not be a challenge for visitors and neither will finding the desired style of accommodation.

## FUTURE CONSTRUCTION

Between 2009 and 2015, anticipated hotel construction will increase the guest room inventory to meet the needs of Toronto's growing tourism sector. The incentive of the 2015 Pan American Games will only enhance that growth. Current projections anticipate that new hotels will provide an additional 2,500 available rooms, primarily in the three-, four- and five-star categories.

OVERVIEW OF HOTEL CAPACITY - 2009				
Class	Number of Hotels	Rooms	Banquet Facilities for Guests	Average Nightly Rate 2009 (US\$)
5 star	13	3,000	Y	\$ 250.00
4 star	33	8,376	Y	\$ 150.00
3 star	79	16,000	Y	\$115.00
2 star	13	2,287	Y	\$70.00
Other (including residences)	97	26,000	Y	N/A
<b>TOTAL</b>	<b>235</b>	<b>55,663</b>		



TORONTO 2015 HOST HOTEL - FAIRMONT ROYAL YORK  
PHOTO CREDIT: FAIRMONT ROYAL YORK



## UNIVERSITY / COLLEGE RESIDENCES

With seven universities and nine colleges in the vicinity of Games sport venues, more than 5,000 residence beds are available for the Games, ensuring that there is a generous selection of low-cost accommodations.

## HOST HOTEL (PASO FAMILY AND SPONSORS)

The Host Hotel will be the Fairmont Royal York Hotel. Opened in 1929, the Royal York is the preeminent hotel in Toronto and a national landmark. Through several multi-million dollar renovations, the hotel has kept up with modern amenities and styles while maintaining its original charm. It offers superb meeting spaces, including a 19th floor banquet room that features a panoramic view of the city from what was, when it was built, the highest floor in the British Commonwealth.

The Royal York has 1,365 guest rooms, extensive conference facilities, a lavish health club, a skylit lap pool, magnificent hand-painted ceilings, crystal chandeliers and the first-ever American Express Travel Service Centre. The Royal York is a hotel fit for all of PASO's needs.

The location of the Royal York is optimal for PASO family requirements as it is less than a ten-minute

walk to the Rogers Centre, the site of the Opening and Closing Ceremonies, and to many other major Games venues.

## MEDIA HOTEL

In accordance with PASO regulations, the designated media hotel(s) will be three- or four-star. Toronto offers a number of hotels in those categories within a tight radius around the Media Centre and key Games venues. The location of the Media Centre (International Broadcast Centre and Main Press Centre) at the Metro Toronto Convention Centre (MTCC) makes the 586-room InterContinental Toronto Centre Hotel the ideal media hotel as it is attached to the MTCC. Other designated Media Hotels are the Renaissance Toronto Hotel (at the Rogers Centre) and the Westin Harbour Castle.

## VISITORS TO THE GAMES

Visitors to the Games will have numerous hotel options from which to choose. From the luxurious and exclusive to the charming and affordable, Toronto's accommodations are sure to suit every taste and budget. Guests will be able to select from a wide range of service levels and locations with multiple options within easy reach of all Games venues.

## ATHLETE FAMILY HOST PROGRAM

Toronto 2015 will initiate an Athlete Family Host Program that invites the families of participating Pan American athletes to billet with Toronto area families for the duration of the Games to help offset the cost of traveling to, and staying in, Toronto to watch family members compete. Host families will provide room and board for the athletes' families, as well as a warm and welcoming environment.



↑ FAIRMONT ROYAL YORK HOTEL - ROOM AND CONFERENCE FACILITIES  
PHOTO CREDIT: FAIRMONT ROYAL YORK

## **SECTION HIGHLIGHTS:**

Getting to Canada is simple. Thirty PASO nations have direct flights to Toronto and the other countries have a choice of connection points, ensuring that all Games participants travel with maximum convenience and speed. NOC's will benefit from a travel support grant that offers real budget relief. On the ground in Toronto, all accredited athletes and officials will be provided with safe, secure and reliable transportation services that ensure timely delivery to and from all accommodations and Games venues. Every NOC will have a dedicated car and driver for the President and another for the Secretary General regardless of team size.



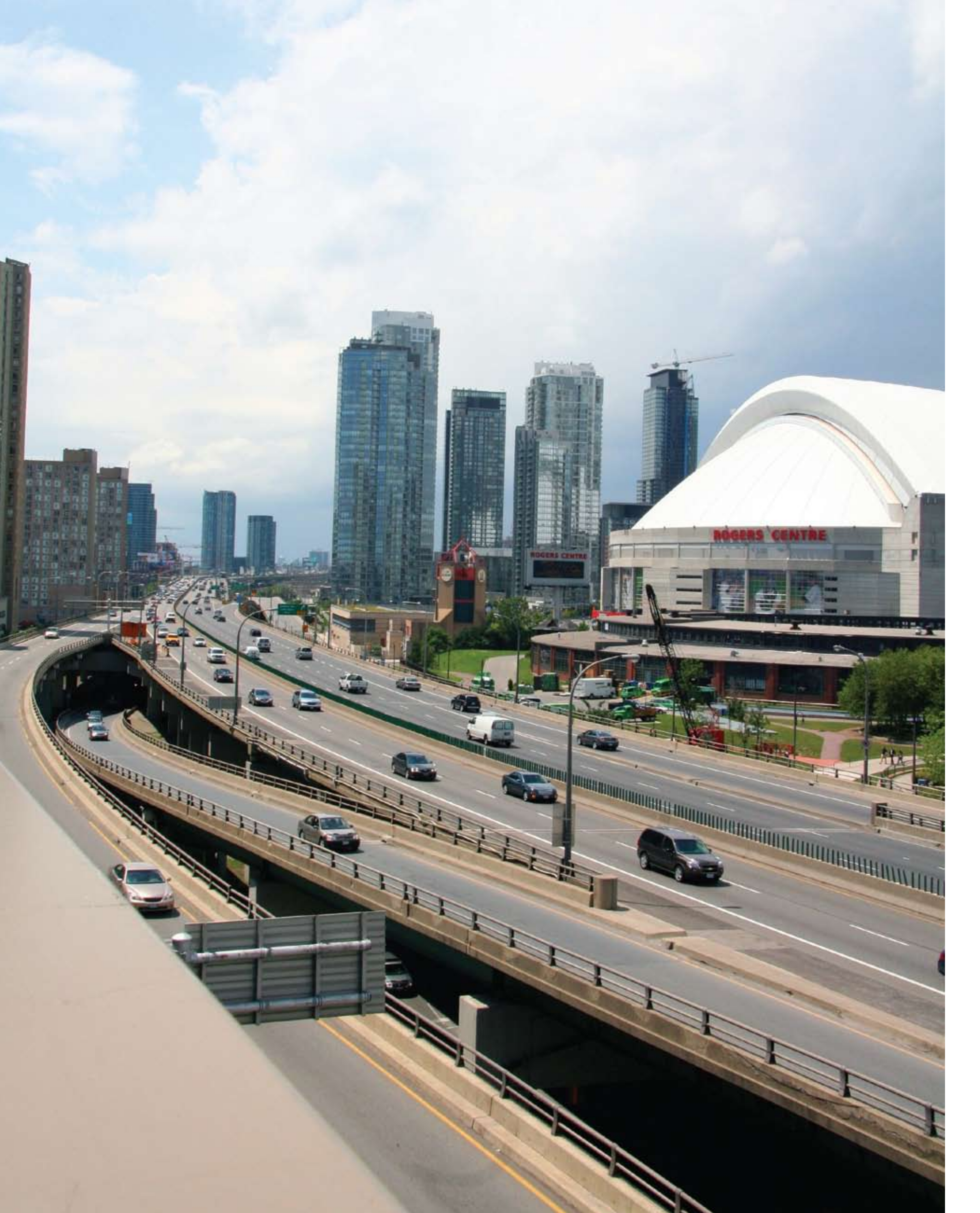

# TRANSPORTATION

## EASY, COST EFFECTIVE, EXPEDITED TRAVEL AND TRANSPORTATION

Toronto 2015 has two straightforward transportation goals – to make it easy and cost effective to get to the Games and easy to get around during the Games.

### TRAVEL SUPPORT GRANT

Toronto 2015 will provide a travel support grant for the Games that will provide real budget relief and allow NOC's to invest their resources in their teams and athletes instead of airfare.

### GETTING TO TORONTO

#### Air Travel

Thirty PASO countries have direct flights to and from Toronto's modern Lester B. Pearson International Airport, an airport that handled 33 million passengers in 2008. This ensures that teams and athletes will arrive with the greatest of convenience and a minimum of delay.

In fact, teams from every PASO country will have travel

options available that provide either convenient direct flights to Toronto or connecting flights through their preferred transfer location to ensure maximum convenience at every step of the journey.

Upon arrival in Canada, a tested, perfected and streamlined immigration and customs service will move teams, PASO family and other accredited individuals swiftly through the airport and then to the Pan American Village or host accommodations along dedicated Pan American road and highway lanes.

Pearson Airport is easily accessible using the region's highway network and is also served by transit buses, airport-specific taxis and limousines and regional airport transit vans. A fixed-rail link from the airport to downtown Toronto – the location of the Pan American Village, Media Centre, Host Hotel and many sport and cultural venues – will be in operation by the start of the Games (construction slated to begin in 2009).

Members of the PASO family will have airport transportation assigned to them according to their accreditation type and level. Full details can be found in the chart on page 75.

#### Airport Welcome Services

The Toronto 2015 Games experience will begin at the airport which will be the arrival point for almost all PASO athletes, dignitaries, teams and officials. Toronto 2015 will have dedicated Welcome Teams on-hand for all of the airport's operating hours to greet arriving guests. Arrival services will be available in all of the major languages of the Americas and Caribbean and the Toronto 2015 Welcome Teams will be able to provide information, assistance and refreshments.

The arrival program will include:

**Immigration Support** – In partnership with Citizenship and Immigration Canada and the Canadian Border Services Agency, Toronto 2015 will work to establish protocols for all arriving Games family. This will include airport meet and greet, as well as support personnel on site to ensure that all members of the PASO family arriving in Toronto have a welcoming, efficient and convenient experience from the first steps off the plane.



GETTING AROUND TORONTO - GARDINER EXPRESSWAY  
NEXT TO THE ROGERS CENTRE PHOTO CREDIT: ONTARIO MINISTRY OF TRANSPORTATION



↑ TORONTO PEARSON AIRPORT  
PHOTO CREDIT: GREATER TORONTO AIRPORT AUTHORITY

**Airport Support Operations** – Once through customs, Games family will be able to avail themselves of the following multilingual services:

**Teams:**

- Toronto 2015 meet and greet team welcome
- Full baggage handling and equipment transfers to the Pan American Village
- Dedicated transport – all buses will be climate-controlled, secure and have staff on-board to explain the welcoming/accreditation process at the Pan American Village and answer general questions

**Games Family, Dignitaries and VIP's:**

- Toronto 2015 meet and greet team welcome in a special location
- Transport – dedicated cars with drivers
- Baggage support

**Spectators and Others:**

- Information kiosks
- Games ticket support

**Departures** – Toronto 2015 will provide services at departure that mirror those provided upon arrival. Recognizing the volume of departing traffic in the days immediately following the conclusion of the Games, in particular the day after the Closing Ceremony of the Games, Toronto 2015 will work with the airport, major air carriers and immigration and customs officials to facilitate a smooth and efficient departure process.

## TRANSPORTATION IN AND AROUND TORONTO

### Subway, Trains, Buses and Streetcars

Historic Union Station, which is connected to the Fairmont Royal York host hotel and is walking distance to the Media Centre and key sport venues like the Rogers Centre and Air Canada Centre, is the central inter-city transportation hub in downtown Toronto and the key connection point for the 27km PATH, an underground pedestrian pathway linking more than 50 key locations in the city core. Union Station is also a hub for local public transportation, regional train and bus service, and intercity train service. Union Station is the highest-capacity transportation station in Canada, easily handling 250,000 passengers each day with expansions planned in advance of 2015.

### Rapid Public Transit

The Toronto region features several transit operators that provide local and rapid inter-regional services. The Toronto Transit Commission (TTC) is North America's second-largest transit operator, serving 1.5 million passengers on a typical weekday. The TTC operates an extensive subway network, along with numerous streetcar and bus routes. Currently, the TTC operates 68 km of subway line, with the construction of an additional 15 km recently approved. Some bus and streetcar routes offer 24-hour service. In addition, work to develop a network of seven new Light Rail Transit (LRT) lines throughout Toronto is underway.

Other municipalities in the Toronto region have extensive transit networks featuring modern and accessible bus fleets that integrate service with the TTC, surrounding transit networks and with GO Transit.

GO Transit, the inter-regional transit provider focused on Toronto, links Toronto with the surrounding regions. GO operates an extensive network of train and bus service that carries 55 million passengers each year and runs 181 train trips and 1,813 bus trips daily, carrying about 195,000 passengers on a typical weekday.

### Roads and Highways

Ontario has an extensive highway network which is well-connected to the border with the United States. Approximately 43.5 million vehicles cross the Canada-U.S. (Ontario-New York State) border every year. Ontario's border with New York State is less than a two-hour drive from downtown Toronto. Modern highways connect the entire region and are closely monitored to ensure their efficient operation. Ontario has also been rated among the safest driving regions in North America.

The City of Toronto itself has an extensive arterial road network that provides for a high level of transit and the city is very familiar with the special operations and protocols which are required to support major events.



↑ TORONTO BIKE TRAILS  
PHOTO CREDIT: TOURISM TORONTO

### Active Transportation

In keeping with the social and environmental goals of the Toronto 2015 Games, self-propelled transportation will be an important component of the Games transportation plan. All sport venues will feature, for example, generous bicycle rack areas to encourage spectators to pedal to the Games.

While the convenience and comfort of automotive transportation will always be available to athletes, team officials, media and the PASO family, Toronto 2015 will also offer a Games Bike Share (GBS) program which will provide

bicycles at all Games venues for use by accredited individuals. The shared bicycles will allow Pan American Village residents the opportunity to use the City of Toronto's bikeways which, by 2015 will cover 1,004 kms.

### Water Transportation

Given that Toronto is ideally located on the shore of Lake Ontario, if desired, water transportation can be used to augment the overall transportation plan.

## THE TORONTO REGION TRANSPORTATION SYSTEM IN 2015

The Government of Ontario is committed to investing in public transit. It has already dedicated \$11.5 billion as part of its MoveOntario 2020 initiative – the largest public-transit investment in Canadian history. In 2008, \$750 million was invested to expand transit fleets and continue transit service improvements.

Metrolinx, the regional transportation authority, is following its regional transportation plan for the Greater Toronto Area and working with municipalities and transit agencies to create a seamless and fully-integrated transportation and transit network with extensions to the existing rail system that will put new stations in close proximity to sport venues for Athletics, Volleyball, Cycling (Track), Water Polo, Rowing and Canoe/Kayak (Sprint).

Dedicated cars and drivers will be provided to the PASO President and Executive Committee members, IOC members, and ISF Presidents.

Additionally, each NOC President and each Secretary General will be allocated a dedicated car and driver, irrespective of team size, for the duration of the Games to provide maximum flexibility for their respective schedules.

## GETTING AROUND TORONTO

### Pan American Games Transportation System

Toronto 2015 will establish Pan American Transport (PAT) to undertake the planning and delivery of all Games transportation programs and services. PAT will contract for fleet transportation services and make necessary arrangements with public and private transport agencies throughout the region. This arrangement will create a single coordinating agency responsible for delivering integrated road, rail and bus transport services. It will also ensure the effective management of transport operations.

### PASO Family

Comprehensive and coordinated transportation services will be provided for the PASO family between the opening of the Pan American Village and three days after the close of the Games. All PASO officials, accredited athletes, team officials and technical officials will be provided with safe, secure and reliable transportation services that ensure timely delivery to and from all accommodations and Games venues.

A fleet of 700 vehicles (buses, mini-buses, vans and automobiles) will be provided for PASO family use and serviced by qualified drivers who will be

## TRANSPORTATION SERVICES

ATHLETES AND TEAM OFFICIALS	
	VEHICLE SERVICE PROVIDED
AIRPORT SHUTTLE	Dedicated air-conditioned Team Vans/Buses
OPENING/CLOSING CEREMONIES	Dedicated air-conditioned Buses
TRAINING AND COMPETITION	Dedicated air-conditioned Team Vans/Buses/Trains
PASO DIGNITARIES	
	VEHICLE SERVICE PROVIDED
PASO PRESIDENT AND EXECUTIVE COMMITTEE	Dedicated, air-conditioned Car and Driver
NOC PRESIDENTS	Dedicated, air-conditioned Car and Driver
NOC SECRETARY GENERALS	Dedicated, air-conditioned Car and Driver
IOC MEMBERS	Dedicated, air-conditioned Car and Driver
ISF PRESIDENTS	Dedicated, air-conditioned Car and Driver
OTHERS (VIP'S, SPONSORS etc)	Pool of dedicated, air-conditioned Cars/Vans with Drivers
PRESS AND BROADCAST MEDIA	
	VEHICLE SERVICE PROVIDED
	Bus/Mini-Bus Shuttle service
TECHNICAL OFFICIALS	
	VEHICLE SERVICE PROVIDED
	Dedicated air-conditioned Vans/Buses

outfitted with appropriate communications and navigational support systems. The fleet will be supported by reserved parking and secure designated transport facilities at the Pan American Village and competition venues.

Priority transportation will be provided along designated Pan American lanes linking Pearson International Airport, the Pan American Village, the host hotel and sport venues. Accompanying baggage will be transported on buses, express trains or, if required, in separate accompanying vehicles.

Sports equipment and horses will be transported safely, securely and expeditiously within the Toronto region between points of arrival and designated accommodations, training and competition venues. Transport services will be provided by insured and bonded contractors utilizing suitable vehicles and related equipment and facilities.



**TORONTO REGION HIGHWAY SYSTEM**  
PHOTO CREDIT: ONTARIO MINISTRY OF TRANSPORTATION



TORONTO PUBLIC TRANSIT  
PHOTO CREDIT: TOURISM TORONTO

### **Pan American Village Transportation**

The internal transportation system will complement the options of walking and cycling (using the Games Bike Share program) within the Pan American Village with quiet, electrically-powered, non-polluting shuttle vehicles which will provide safe and convenient movement throughout the Village.

### **Accredited Individuals Games Transportation**

All individuals who receive Games accreditation will have access to complimentary transportation services to allow them to travel among Games venues and throughout the Toronto region with convenience and confidence. The exact nature of the transportation varies with the different accreditation categories.

## **MEDIA PERSONNEL AND BROADCAST-RIGHTS VEHICLES**

From the opening of the Pan American Village until three days following the close of the Games, accredited reporters and broadcast media will be provided with timely scheduled transportation services 24 hours a day. The services will connect Pearson International Airport, designated accommodations, the Media Centre and training and competition venues. Access and parking will be provided for accredited broadcast-rights media vehicles at the Media Centre and sport venues.

A fleet of 150 buses, minibuses and vans will be dedicated to the service of accredited media personnel and will have access to designated Pan American lanes. Multilingual assistance will be provided to accredited media.

## **SECTION HIGHLIGHTS:**

From July 10 to July 26, 2015, the Toronto region will be alive with the Pan American Games. The timing is ideal. The weather will be optimal. The athletes will be competing at their best because the scheduling of the Toronto Games will fit comfortably into the major competitive seasons. The Toronto 2015 Sport Program will also be responsive to including PASO-identified sports while setting the stage for the 2016 Olympic Summer Games.





# SPORT PROGRAM

## OPTIMAL SPORT PROGRAM. OPTIMAL CONDITIONS.

The proposed dates for the Toronto 2015 Pan American Games are Friday, July 10 to Sunday, July 26, 2015. These dates are ideal for a number of reasons. They offer optimal conditions in terms of weather and daylight. July is prime vacation time in Canada for both school children and working adults, meaning that more people will be available to spend time at the Games. This also means that regular commuter traffic will be at a minimum, adding yet another beneficial factor to the Games' outstanding transportation plan. July is peak tourist season in Toronto, particularly for American visitors. This will enhance the potential market for the Games, particularly for ticket and merchandise sales. Toronto festivals and cultural offerings are also in full swing during these summer months, providing a large number of entertainment options before, during and after the Games. Toronto 2015 will ensure, however, that the 2015 Pan American Games are not in direct competition with any other major sport events. Finally, these competition dates will help ensure a high-quality field in most sports as this will place the Pan American Games appropriately within the major competitive seasons.

The sport venues will be world-class and in full compliance with International Sport Federations specifications.

## VOLUNTEER PLAN

The Toronto 2015 operational plan calls for approximately 19,000 volunteers. Depending on their individual roles, many will have sport-specific knowledge and/or be multilingual. All volunteers will go through rigorous screening and training programs, ensuring the best experience for everyone who comes in contact with Toronto 2015 volunteers.

Volunteer recruitment will begin well in advance of the Games. All volunteers will be part of a best-practices program of recruitment, orientation, training, management and recognition. All volunteer services will be available in the major languages of the Western Hemisphere including Spanish, Portuguese, English and French.

The City of Toronto already has a team of Special Events Volunteers – more than 1,000 volunteers from diverse backgrounds. Other communities supporting the Games have similar cohorts of experienced volunteers who have been involved in hosting major sport events such as the Canadian Open (PGA Tour golf) or the Road World Cycling Championships. Toronto 2015 will also recruit volunteers from across the country, reaching out particularly to the experienced volunteer corps from the Vancouver 2010 Olympic Winter Games.

## SPORT PROGRAM

The Toronto 2015 Sport Program will reflect:

1. The 2016 Olympic Summer Sport Program
2. The Pan American sports selected by PASO

The Toronto 2015 Sport Program includes the 26 sports on the current Olympic Summer Program and the Pan American Sports noted below. Toronto 2015 recognizes that the Sport Program cannot be confirmed at this time and that the Sport Program will not be finalized for the 2015 Pan American Games until, in the case of Olympic sports, the time of the IOC Session in Copenhagen, Denmark, in October of 2009, and in the case of the Pan American sports, closer to the date of the Games, as per PASO regulations. Toronto 2015 is planning now for the inclusion of a number of sports under those provisions to ensure complete readiness and adaptability.

SPORTS CURRENTLY ON THE OLYMPIC PROGRAM (26)	
Aquatics	Handball
Archery	Judo
Athletics	Modern Pentathlon
Badminton	Rowing
Basketball	Sailing
Boxing	Shooting
Canoe/Kayak	Table Tennis
Cycling	Taekwondo
Equestrian	Tennis
Fencing	Triathlon
Field Hockey	Volleyball
Football	Weightlifting
Gymnastics	Wrestling
TENTATIVE LIST OF ADDITIONAL SPORTS (10) Subject to change according to PASO regulations	
Baseball	Roller Sports
Bowling	Rugby Sevens
Futsal	Softball
Karate	Squash
Racquetball	Water Ski/Wakeboard



↑ JERMAIN ANDERSON, CANADIAN NATIONAL BASKETBALL TEAM - 2007 PAN AMERICAN GAMES  
PHOTO CREDIT: CANADIAN OLYMPIC COMMITTEE

2015 PAN AMERICAN GAMES SCHEDULE

JULY

EVENT	VENUE NAME	Thu	Fri	Sat	Sun	Mon	Tue	Wed	Thu	Fri	Sat	Sun	Mon	Tue	Wed	Thu	Fri	Sat	Sun
		9	10	11	12	13	14	15	16	17	18	19	20	21	22	23	24	25	26
OPENING CEREMONIES	ROGERS CENTRE		●																
CLOSING CEREMONIES	ROGERS CENTRE																		●
AQUATICS - DIVING	PAN AMERICAN AQUATICS CENTRE										●	●	●	●					
AQUATICS - OPEN WATER SWIM	WELLAND INTERNATIONAL FLATWATER CENTRE						●												
AQUATICS - SWIMMING	PAN AMERICAN AQUATICS CENTRE			●	●	●	●	●	●	●									
AQUATICS - SYNCHRO SWIMMING	PAN AMERICAN AQUATICS CENTRE														●	●	●	●	
AQUATICS - WATER POLO (W)	MARKHAM POOL			●	●	●	●		●										
AQUATICS - WATER POLO (M)	MARKHAM POOL										●	●	●	●		●			
ARCHERY	E.T. SETON PARK													●	●	●	●	●	●
ATHLETICS	PAN AMERICAN STADIUM												●	●	●	●	●	●	●
BADMINTON	BILL CROTHERS SECONDARY SCHOOL													●	●	●	●	●	●
BASEBALL*	ROGERS CENTRE AND RICHMOND GREEN SPORTS PARK						●	●	●	●	●	●	●	●					
BASKETBALL (W)	AIR CANADA CENTRE								●	●	●	●	●						
BASKETBALL (M)	AIR CANADA CENTRE												●	●	●	●	●	●	●
BOWLING - 10-PIN*	CLASSIC BOWL												●	●	●	●	●	●	●
BOXING	GENERAL MOTORS CENTRE								●	●	●	●	●	●	●	●	●	●	●
CANOE/KAYAK - SPRINT	WELLAND INTERNATIONAL FLATWATER CENTRE			●	●														
CANOE/KAYAK - SLALOM	MINDEN WILD WATER PRESERVE			●	●														
CYCLING - BMX	ONTARIO PLACE																		●
CYCLING - MOUNTAIN BIKE	HARDWOOD SKI AND BIKE					●													
CYCLING - ROAD	EXHIBITION PLACE START / FINISH				●							●							
CYCLING - TRACK	PAN AMERICAN VELODROME													●	●	●	●	●	●
EQUESTRIAN - DRESSAGE	CALEDON EQUESTRIAN PARK			●	●	●	●												
EQUESTRIAN - 3-DAY EVENTING	CALEDON EQUESTRIAN PARK										●	●	●						
EQUESTRIAN - SHOW JUMPING	CALEDON EQUESTRIAN PARK														●	●	●	●	●
FOOTBALL (W)	BMO FIELD, RON JOYCE STADIUM, SHERWOOD PARK, VARSITY STADIUM	●		●		●		●		●		●		●		●	●	●	●
FOOTBALL (M)	BMO FIELD, RON JOYCE STADIUM, SHERWOOD PARK, VARSITY STADIUM				●			●		●		●		●		●	●	●	●
FUTSAL*	GOLDRING CENTRE FOR HIGH PERFORMANCE SPORT													●	●	●	●	●	●
FIELD HOCKEY (W)	PAN AMERICAN FIELD HOCKEY CENTRE							●		●		●		●		●		●	●
FIELD HOCKEY (M)	PAN AMERICAN FIELD HOCKEY CENTRE							●		●		●		●		●		●	●
FENCING	CANADIAN SPORT INSTITUTE ONTARIO										●	●	●	●	●	●	●	●	●
GYMNASTICS - ARTISTIC	RICOH COLISEUM			●	●	●	●												
GYMNASTICS - RHYTHMIC	RICOH COLISEUM														●	●	●	●	●
GYMNASTICS - TRAMPOLINE	RICOH COLISEUM														●	●	●	●	●
HANDBALL - TEAM (W)	DIRECT ENERGY									●		●		●		●		●	●
HANDBALL - TEAM (M)	DIRECT ENERGY										●		●		●		●		●
JUDO	HERSHEY CENTRE												●	●	●	●	●	●	●
KARATE*	DIRECT ENERGY			●	●	●													
MODERN PENTATHLON	CANADIAN SPORT INSTITUTE ONTARIO, PAN AMERICAN AQUATICS CENTRE, PICKERING HORSE CENTRE										●	●							
RACQUETBALL*	RYERSON UNIVERSITY												●	●	●	●	●	●	●
ROLLER SPORTS - ARTISTIC*	HERSHEY SPORT ZONE												●	●	●	●	●	●	●
ROLLER SPORTS - TRACK*	HERSHEY SPORT ZONE														●	●	●	●	●
ROWING	ROYAL CANADIAN HENLEY ROWING COURSE			●	●	●	●	●	●										
RUGBY SEVENS (W)*	FLETCHER'S FIELD														●	●			
RUGBY SEVENS (M)*	FLETCHER'S FIELD															●	●		
SAILING	ROYAL CANADIAN YACHT CLUB					●	●	●	●	●	●	●							
SOFTBALL (W)*	LAKEFRONT WEST PARK												●	●	●	●	●	●	●
SHOOTING - INDOOR	AJAX COMMUNITY CENTRE			●	●	●	●	●	●										
SHOOTING - OUTDOOR	OSHAWA GUN AND SKEET CLUB			●	●	●	●	●	●	●									
SQUASH*	JOHN BASSETT THEATRE & METRO TORONTO CONVENTION CENTRE												●	●	●	●	●	●	●
TAEKWONDO	HERSHEY CENTRE			●	●	●	●												
TENNIS	REXALL TENNIS CENTRE					●	●	●	●	●	●	●	●	●	●	●	●	●	●
TRIATHLON	ONTARIO PLACE			●															
TABLE TENNIS	CENTENNIAL COMMUNITY CENTRE			●	●	●	●	●	●	●	●								
VOLLEYBALL - INDOOR (W)	COPPS COLISEUM			●	●	●		●	●										
VOLLEYBALL - INDOOR (M)	COPPS COLISEUM										●	●	●		●	●			
VOLLEYBALL - BEACH	EXHIBITION PLACE					●	●	●	●	●	●	●	●						
WATER SKI/WAKEBOARD*	LONG POND - TORONTO ISLAND														●	●	●	●	●
WEIGHTLIFTING	ROY THOMSON HALL				●	●	●	●	●										
WRESTLING	POWERADE CENTRE														●	●	●	●	●

● Competition ● Finals (May include Competitions) ● Ceremonies \* Subject to PASO Executive Committee approval and direction



## **SECTION HIGHLIGHTS:**

By using a “venue cluster” plan that combines the best features of a condensed Games layout with the advantages of a regional model, Toronto 2015 will help build enthusiasm, market reach and legacy impact without sacrificing security, convenience or access. All venues, both new and existing, will meet or exceed the world-class standards of every sport’s International Federation and offer test events before 2015, maximizing the readiness of both venues and athletes.





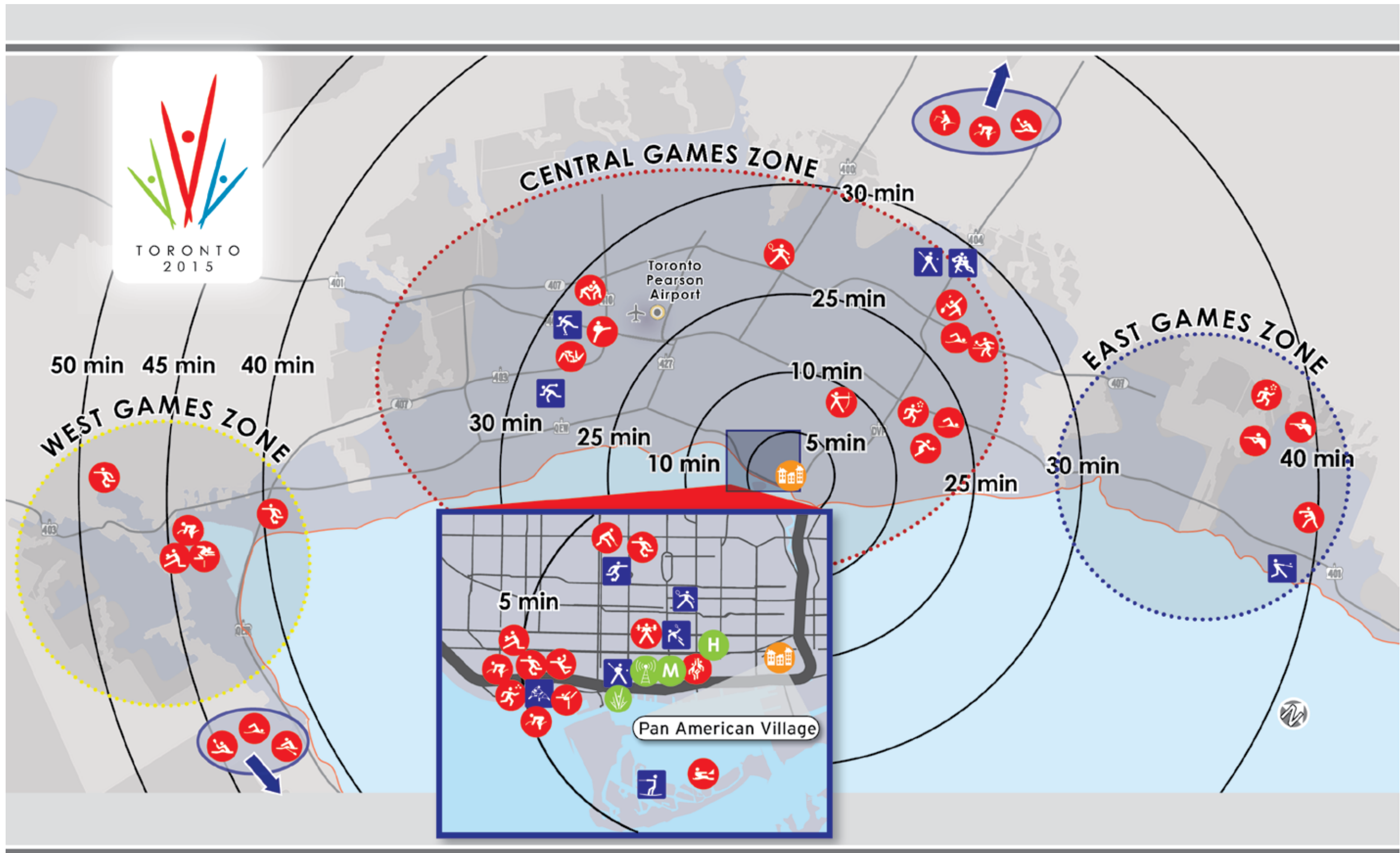

- |                              |                |             |               |                   |                     |               |
|------------------------------|----------------|-------------|---------------|-------------------|---------------------|---------------|
| Pan American Village         | Athletics      | Basketball  | Equestrian    | Gymnastics        | Rowing              | Tennis        |
| Host Hotel                   | Aquatics       | Boxing      | Fencing       | Handball          | Sailing             | Triathlon     |
| Media Centre                 | Archery        | Canoe/Kayak | Field Hockey  | Judo              | Shooting            | Volleyball    |
| Media Hotel                  | Badminton      | Cycling     | Football      | Modern Pentathlon | Table Tennis        | Weightlifting |
| Opening & Closing Ceremonies | Bowling 10-Pin | Karate      | Roller Sports | Softball          | Taekwondo           | Wrestling     |
| Baseball                     | Futsal         | Raquetball  | Rugby Sevens  | Squash            | Water Ski/Wakeboard |               |

● Olympic Sports    
 ■ Pan American Sports    
 ■ Non-Sport Venues

# VENUES

## OVERVIEW OF THE SPORT VENUE DEVELOPMENT PROGRAM

Facilities in the Toronto 2015 sport venue development program will be world-class and inclusive. In order to achieve these goals, each venue, both existing and new, will meet sport-specific criteria and standards dictated by its International Sport Federation.

## DEFINING A “WORLD-CLASS” SPORT VENUE

To be world-class, every venue must meet the technical requirements of the highest level of international competition, as defined by each sport’s International Federation. But being “world-class” is so much more than measurements and specifications. A world-class venue:

- Meets sport-by-sport IF standards,
- Provides spectator capacity that matches the appeal of the highest level of competition for that particular sport in the Host City,
- Provides facilities and capacity for the variety, level and number of media attracted to the highest level of competition,
- Offers “back of house” facilities (especially important at multi-sport games) that meet the same elite standards as the “field of competition” spaces,
- Is accessible and inclusive in its design and its program content,
- Enhances the spectator experience with comfort, convenience, features and sight-lines that allow full enjoyment of the competition, and
- Captures a sense of place, style and/or purpose.

To be inclusive, every facility must manifest the principles of “Universal Design,” a widely applied concept which refers to the design of products and environments to be usable by all people. The concept was developed and trademarked by North Carolina State University. Toronto 2015 will design both the physical venues and, just as importantly, the programs and activities they host, to meet the seven principles of Universal Design.

- Equitable Use
- Flexibility in Use
- Simple and Intuitive
- Perceptible Information
- Tolerance for Error
- Low Physical Effort
- Size and Space for Approach and Use

## TEST EVENTS

Beginning in 2014, all Toronto 2015 sport venues will host domestic and international competitions that will allow athletes to compete in the venues before the 2015 Games. These events will also serve as opportunities to test facility systems and procedures to ensure full readiness in July 2015.

## VENUE CLUSTERS

Closely-arranged venues provide convenience for Games participants of all kinds, while more widely-dispersed venues help enhance the market penetration and legacy potential of the Games and minimizes congestion and security issues. Toronto 2015 has created a venue plan which taps into the benefits of both approaches by working with a venue cluster model.

The four sport venue clusters are:

CENTRAL GAMES ZONE:
Opening and Closing Ceremonies
Pan Am Village
Media Centre (Main Press Centre International Broadcasting Centre)
Host Hotel
Media Hotel
Aquatics (Swimming, Diving, Synchronized Swimming, Water Polo)
Archery
Badminton
Baseball
Basketball
Bowling*
Cycling (Road and BMX)
Field Hockey
Football
Futsal*
Fencing
Gymnastics
Handball
Judo
Karate*
Modern Pentathlon
Racquetball*
Roller Sports*
Rugby*
Sailing
Squash*
Table Tennis
Taekwondo
Tennis
Triathlon
Volleyball (Beach)
Water Ski/Wakeboard*
Weightlifting
Wrestling

EAST GAMES ZONE:
Boxing
Modern Pentathlon
Softball*
Shooting

WEST GAMES ZONE:
Athletics
Cycling (Track)
Football
Volleyball (Indoor)

OTHER CLUSTER:
Aquatics (Open Water Swimming)
Canoe /Kayak
Rowing
Cycling (Mountain Biking)
Equestrian

\* Subject to PASO Executive Committee approval and direction

## SPORTS

AQUATICS	88	SHOOTING - OUTDOOR	125
ARCHERY	90	TABLE TENNIS	126
ATHLETICS	92	TAEKWONDO	128
BADMINTON	94	TENNIS	130
BASKETBALL	96	TRIATHLON	132
BOXING	98	VOLLEYBALL - INDOOR	134
CANOE/KAYAK - SPRINT	100	VOLLEYBALL - BEACH	135
CANOE/KAYAK - SLALOM	101	WEIGHTLIFTING	136
CYCLING	102	WRESTLING	138
EQUESTRIAN	104	BASEBALL	140
FENCING	106	BOWLING - 10-PIN	142
FIELD HOCKEY	108	FUTSAL	144
FOOTBALL	110	KARATE	146
GYMNASTICS	112	RACQUETBALL	148
HANDBALL	114	ROLLER SPORTS	150
JUDO	116	RUGBY SEVENS	152
MODERN PENTATHLON	118	SOFTBALL	154
ROWING	120	SQUASH	156
SAILING	122	WATER SKI/WAKEBOARD	158
SHOOTING - INDOOR	124		

■ Olympic Program

■ Subject to PASO Executive Committee approval and direction



# SPORT: AQUATICS

## VENUES:

**A | PAN AMERICAN AQUATICS CENTRE**

**B | MARKHAM POOL**

**C | WELLAND INTERNATIONAL FLATWATER CENTRE (WIFC)**

The Pan American Aquatics Centre will be one of the most significant new developments of the 2015 Pan American Games.

The state of art facility will include the amenities required for both international competition and training, and include dedicated areas for all indoor aquatics sports with a dedicated dive tank and two 50m, ten-lane pools.

Located on the grounds of the University of Toronto and the City of Toronto, the Pan American Aquatics Centre is a collaborative project between the University, the City of Toronto and the 2015 Pan American Games, which combines the needs of a major event, Canada's largest university, and Canada's largest city.

## > SPORT & VENUE SPECIFICATIONS

### A | PAN AMERICAN AQUATICS CENTRE – SWIMMING, DIVING, SYNCHRONIZED SWIMMING

#### CURRENT STATUS

- New Build
- Construction Status: Completed by 2014
- Current/Future owner: University of Toronto/City of Toronto

#### VENUE HIGHLIGHTS

- Meets all International Federation specifications
- Seating Capacity: 10,000
- Distance from village: 22 minutes/29km
- Parking spaces: over 3,000

#### CURRENT AND POST GAMES USE

- The facility will link together community sport and recreation use, competitive use by university and sports clubs, a national training centre for Canada's top athletes and provide a venue to host the world for major national and international competitions.



## > COMPETITION SCHEDULE

JULY																		
Day	Thu	Fri	Sat	Sun	Mon	Tues	Wed	Thu	Fri	Sat	Sun	Mon	Tue	Wed	Thu	Fri	Sat	Sun
Date	9	10	11	12	13	14	15	16	17	18	19	20	21	22	23	24	25	26
VENUE: PAN AMERICAN AQUATICS CENTRE																		
Swimming			●	●	●	●	●	●	●									
Diving										●	●	●	●					
Synchro Swimming														●	●	●	●	
VENUE: MARKHAM POOL																		
Water polo (W)			●	●	●	●		●										
Water polo (M)										●	●	●	●		●			
VENUE: WELLAND INTERNATIONAL FLATWATER CENTRE																		
Open Water Swim						●												

● Competition      ● Finals (may include competitions on these days)

> COMPETITION SITE PLANS

A | PAN AMERICAN AQUATICS CENTRE

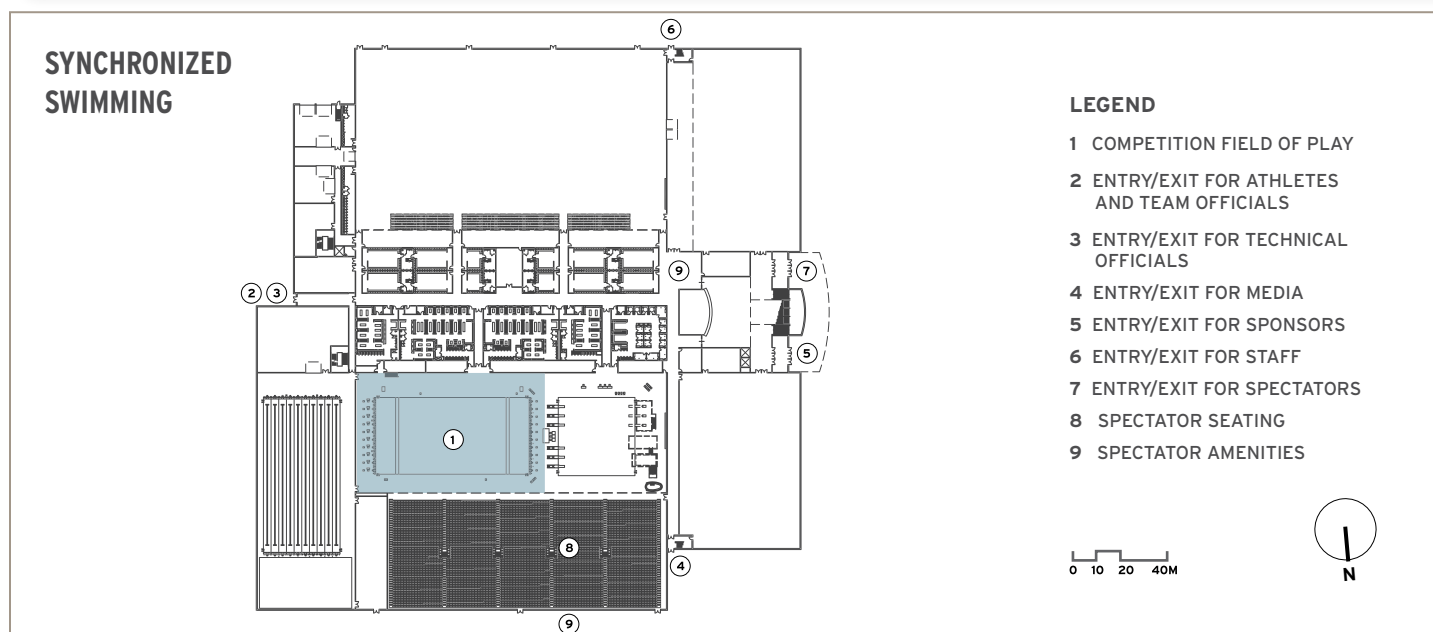
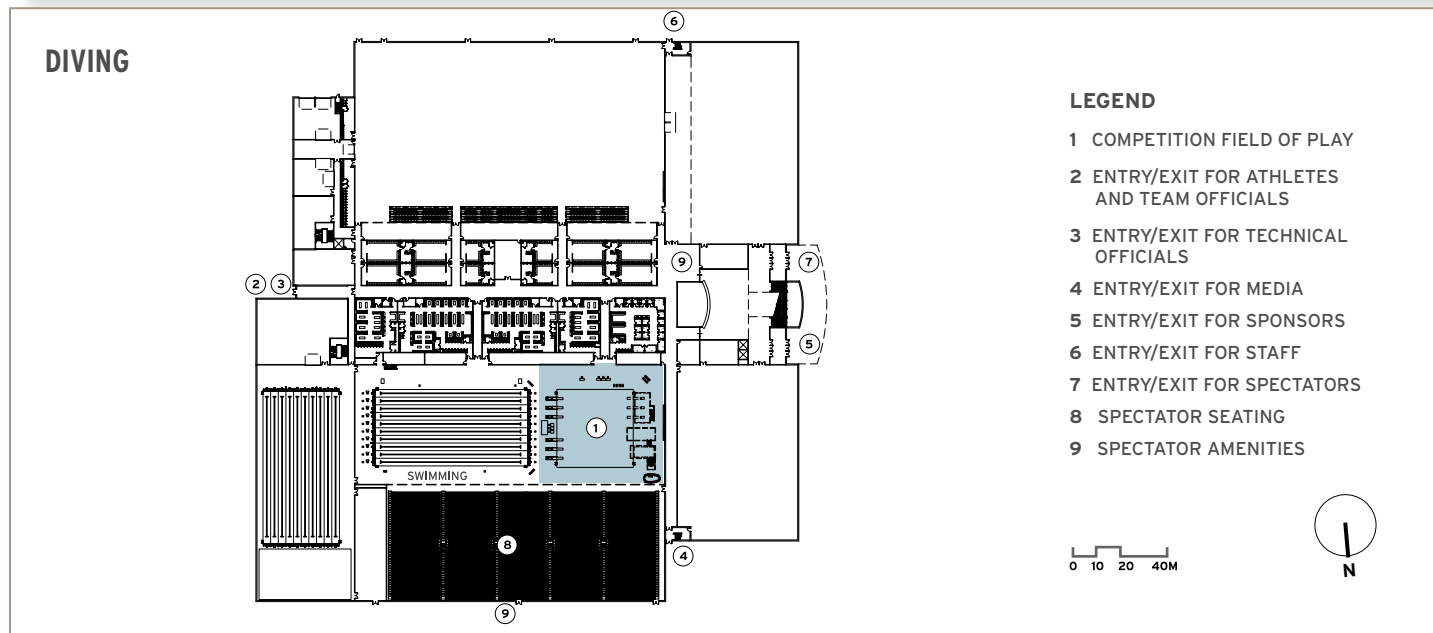
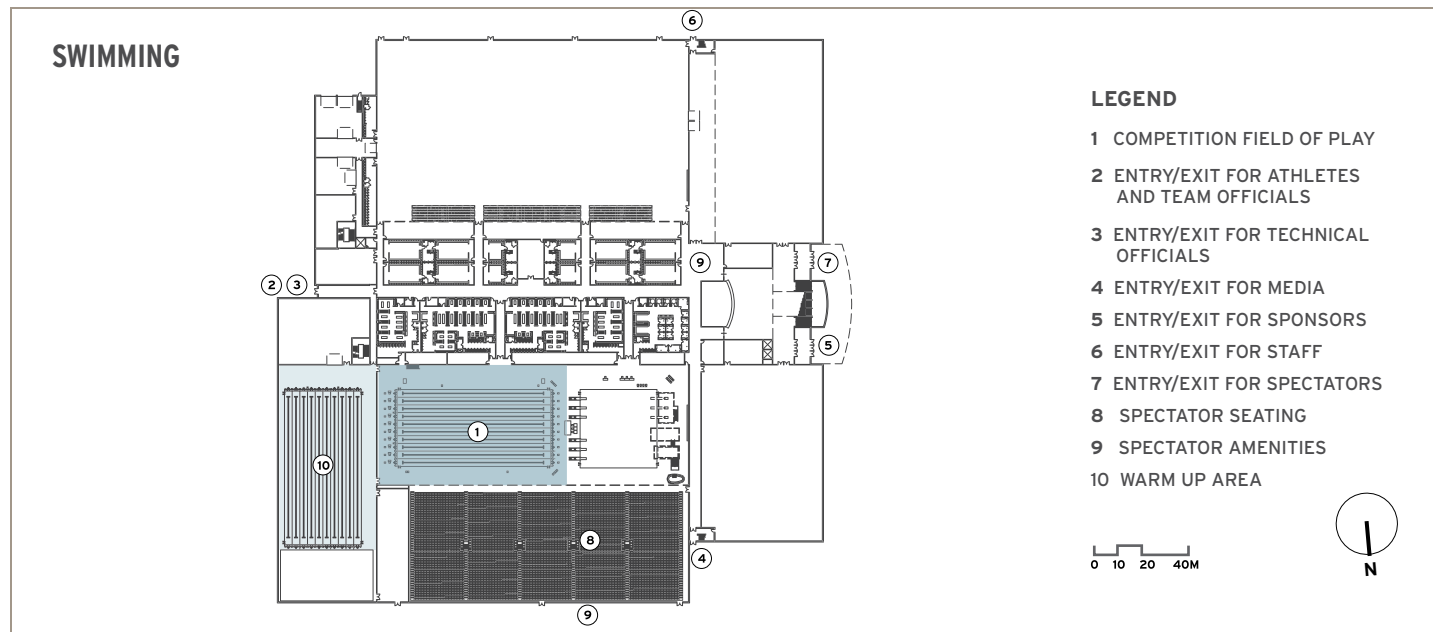

B | MARKHAM POOL - WATER POLO

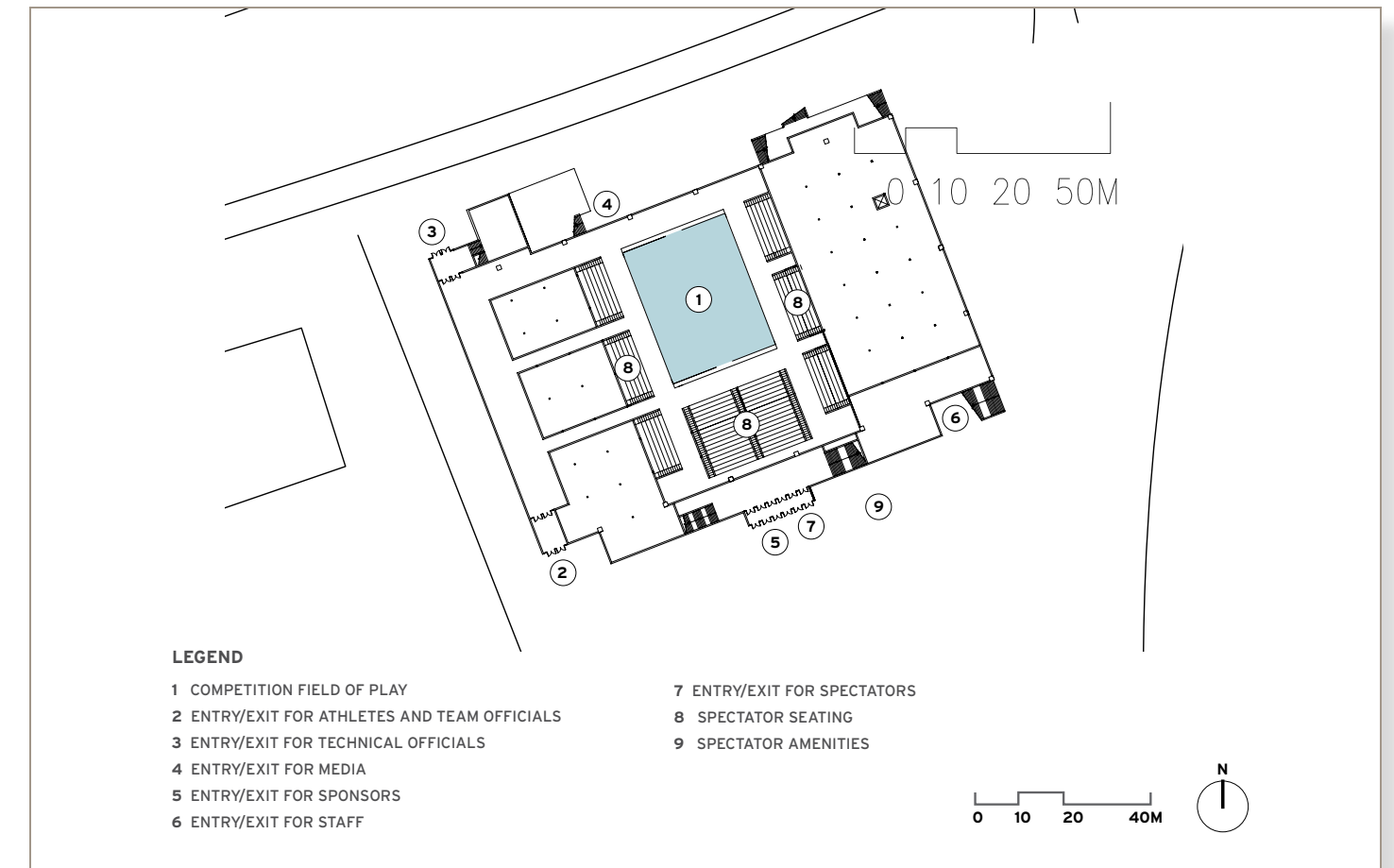

C | WELLAND INTERNATIONAL FLATWATER CENTRE (WIFC) - OPEN WATER SWIMMING

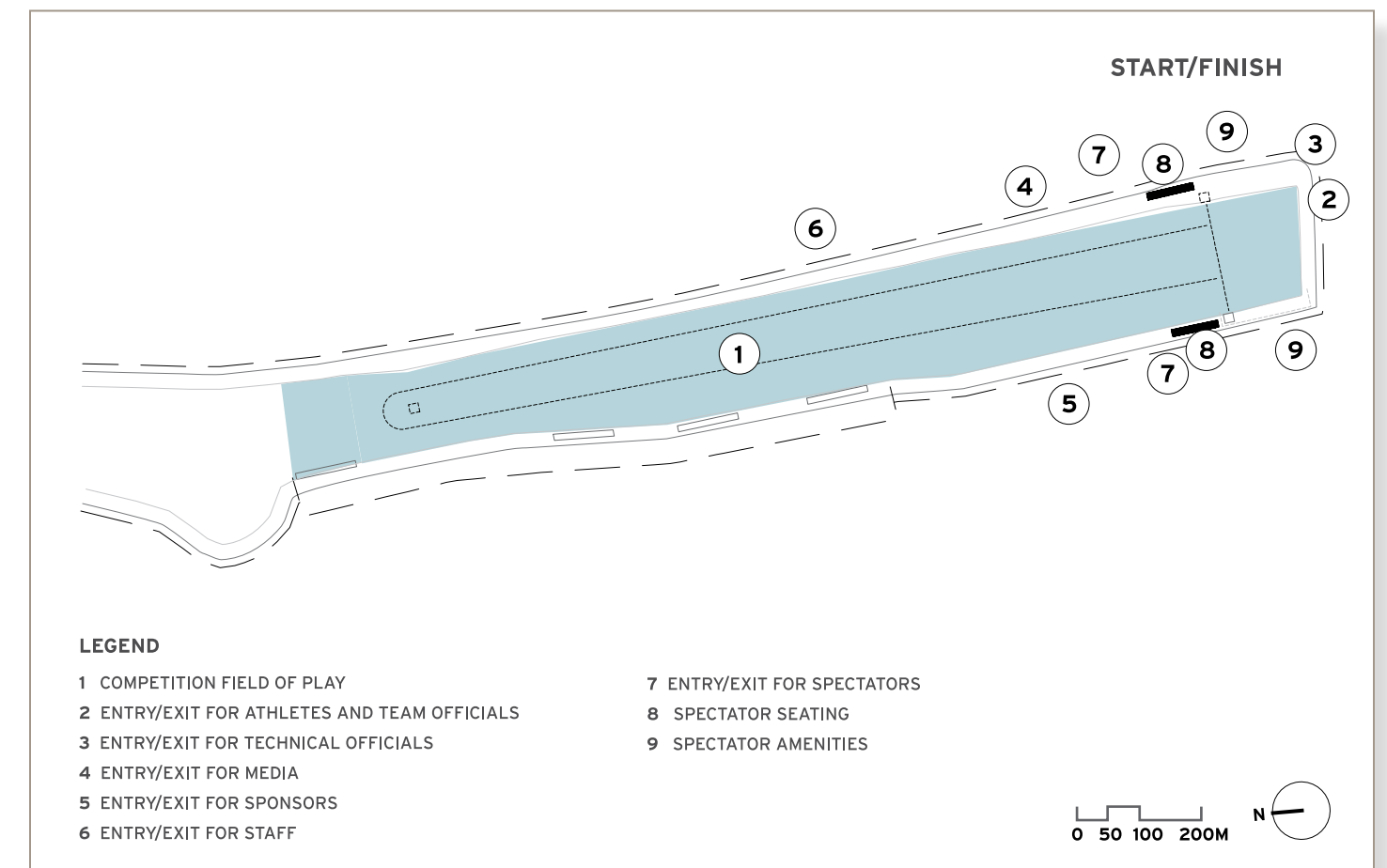

**B | MARKHAM POOL - WATER POLO**

The Markham Pool is a new development that provides a competitive venue for the Games and leaves behind a lasting legacy that will support sport development at all levels, as well as community use for recreational purposes.

During the Games, this aquatics venue will be dedicated exclusively to the sport of Water Polo, providing a tailored venue to enhance the sightlines and overall experience of participants and spectators alike.

Given the close proximity to the competitive venues for table tennis and badminton, it will create a significant cluster of sports, enhancing spectator opportunities during the Games.

CURRENT STATUS
<ul style="list-style-type: none"> <li>New Build</li> <li>Construction Status: Completed by 2014</li> <li>Current/Future owner: Town of Markham</li> </ul>
VENUE HIGHLIGHTS
<ul style="list-style-type: none"> <li>Meets all International Federation specifications</li> <li>Seating Capacity: 3,000</li> <li>Distance from village: 27 minutes / 29 km</li> <li>Parking spaces: over 1,000</li> </ul>
CURRENT AND POST GAMES USE
<ul style="list-style-type: none"> <li>The facility will link together community sport and recreation use, competitive use by sports clubs, as well as training and competition for Canada's top athletes.</li> </ul>



**C | WELLAND INTERNATIONAL FLATWATER CENTRE (WIFC) - OPEN WATER SWIMMING**

The Welland International Flatwater Centre is located on the former Welland Canal, developed to bypass the magnificent Niagara Falls and create an in-land shipping channel through the Eastern part of Canada.

With its controlled and protected waters, the venue provides pristine water conditions and consistent depth throughout, a perfect location for open water swimming.

A legacy project of the Games, this venue will be a national training centre for Canoe/Kayak.

CURRENT STATUS
<ul style="list-style-type: none"> <li>Existing / Retrofit</li> <li>Construction State: Completed by 2014</li> <li>Current/Future owner: City of Welland</li> </ul>
VENUE HIGHLIGHTS
<ul style="list-style-type: none"> <li>Meets all International Federation specifications</li> <li>Seating Capacity: 2,500</li> <li>Distance from village: 99 minutes / 134 km</li> <li>Parking spaces: over 1,000</li> </ul>
CURRENT AND POST GAMES USE
<ul style="list-style-type: none"> <li>Currently plays host to numerous championships each year in addition to being a training ground for recreational and competitive paddlers.</li> <li>As a legacy project for the Games, facility will further evolve as a national training centre, capable of hosting major national and international events.</li> </ul>



**SPORT: ARCHERY**

**VENUE: E.T. Seton Park**

E.T. Seton Park is a City of Toronto Park, located in the northeast part of Toronto, which includes an archery range, equestrian trails, nordic skiing trails and picnic areas. The park is also home to the Ontario Science Centre.

At a short distance from the Pan American Village, this beautiful natural setting in an urban park provides a sheltered venue that will deliver high level competition and adjacent warm-up/training area for all competitors.

**> SPORT & VENUE SPECIFICATIONS**

CURRENT STATUS
<ul style="list-style-type: none"> <li>Existing</li> <li>Current/Future Owner: City of Toronto</li> </ul>
VENUE HIGHLIGHTS
<ul style="list-style-type: none"> <li>Meets all International Federation specifications</li> <li>Seating Capacity: 1,000</li> <li>Distance from village: 10 minutes / 12km</li> <li>Parking spaces: over 500</li> </ul>
CURRENT AND POST GAMES USE
<ul style="list-style-type: none"> <li>E.T. Seton Park will continue to be a community asset and, with the field of play upgrades for the archery component of the games, continue to be an asset for sport development at all levels.</li> </ul>



**> COMPETITION SCHEDULE**

JULY																		
Day	Thu	Fri	Sat	Sun	Mon	Tues	Wed	Thu	Fri	Sat	Sun	Mon	Tue	Wed	Thu	Fri	Sat	Sun
Date	9	10	11	12	13	14	15	16	17	18	19	20	21	22	23	24	25	26
Archery													●	●	●	●	●	

● Competition ● Finals (may include competitions on these days)



> COMPETITION SITE PLAN

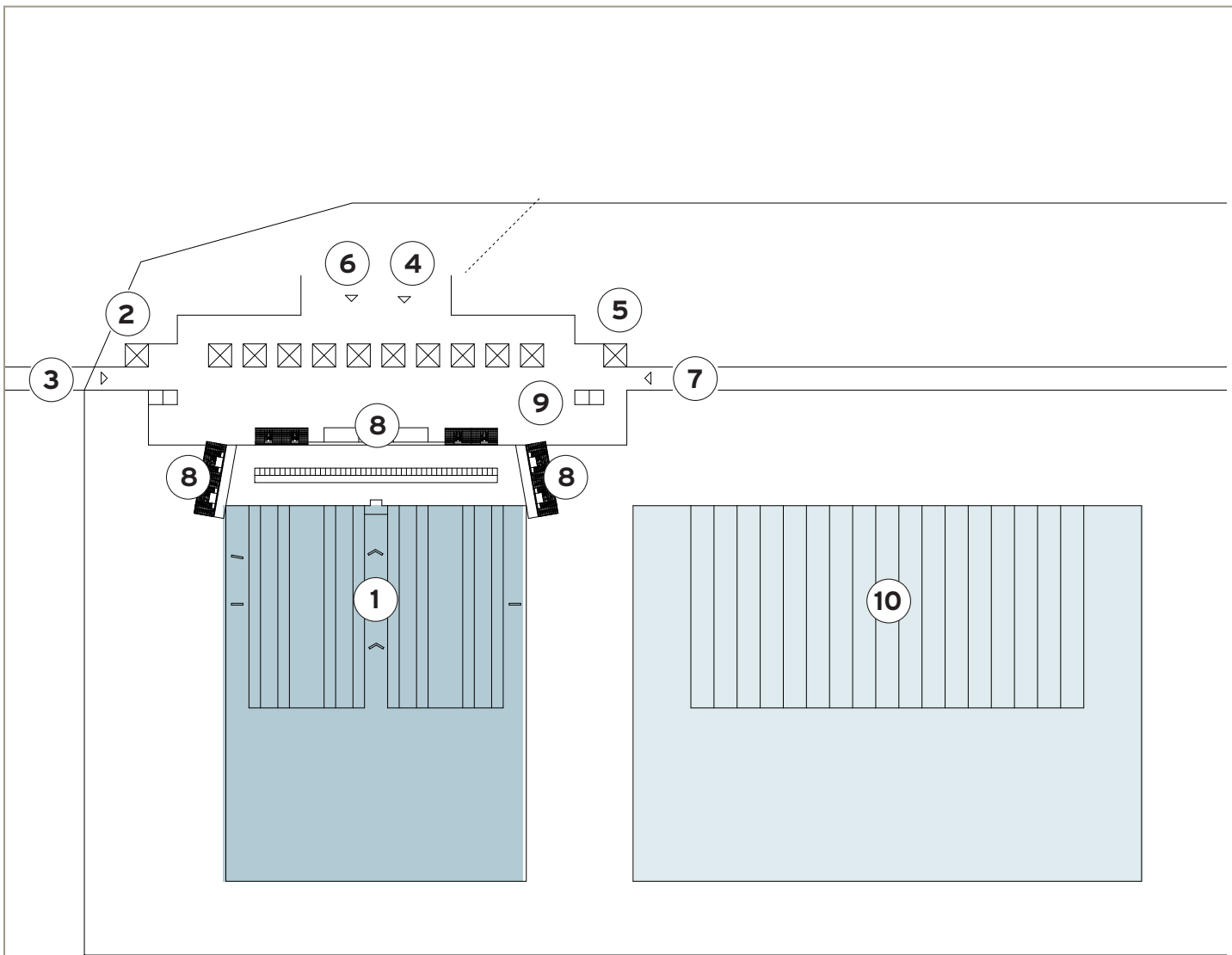

**LEGEND**

- 1 COMPETITION FIELD OF PLAY
- 2 ENTRY/EXIT FOR ATHLETES AND TEAM OFFICIALS
- 3 ENTRY/EXIT FOR TECHNICAL OFFICIALS
- 4 ENTRY/EXIT FOR MEDIA
- 5 ENTRY/EXIT FOR SPONSORS
- 6 ENTRY/EXIT FOR STAFF
- 7 ENTRY/EXIT FOR SPECTATORS
- 8 SPECTATOR SEATING
- 9 SPECTATOR AMENITIES
- 10 WARM UP AREA



## SPORT: ATHLETICS

### VENUE: Pan American Stadium

As an important new development, the Pan American Stadium will be a significant project as part of the Games' Venue Plan, and provide a legacy directly related to hosting the 2015 Pan American Games.

The new 15,000-seat stadium will include a leading-edge 400m running track with all the required areas for throwing and jumping disciplines. An adjacent warm-up training track, replicating the features of the Stadium will be added to the site to create a premier national training centre for Athletics, capable of hosting national and international events following the Games.

### > SPORT & VENUE SPECIFICATIONS

#### CURRENT STATUS

- New build
- Construction Status: Completed by 2014
- Current/Future Owner: City of Hamilton

#### VENUE HIGHLIGHTS

- Meets all International Federation specifications
- Seating Capacity: 15,000
- Distance from village: 45 minutes/68km
- Parking spaces: 8,400

#### CURRENT AND POST GAMES USE

- Post Games, the Pan American Stadium will remain as a national training centre supporting national sport development objectives, and capable of hosting major national and international events.
- The facility will also be a significant multi-purpose community asset that will serve the broad needs of the region.



### > COMPETITION SCHEDULE

JULY																		
Day	Thu	Fri	Sat	Sun	Mon	Tues	Wed	Thu	Fri	Sat	Sun	Mon	Tue	Wed	Thu	Fri	Sat	Sun
Date	9	10	11	12	13	14	15	16	17	18	19	20	21	22	23	24	25	26
Athletics											●	●	●	●	●	●	●	

- Finals (may include competitions on these days)

> COMPETITION SITE PLAN

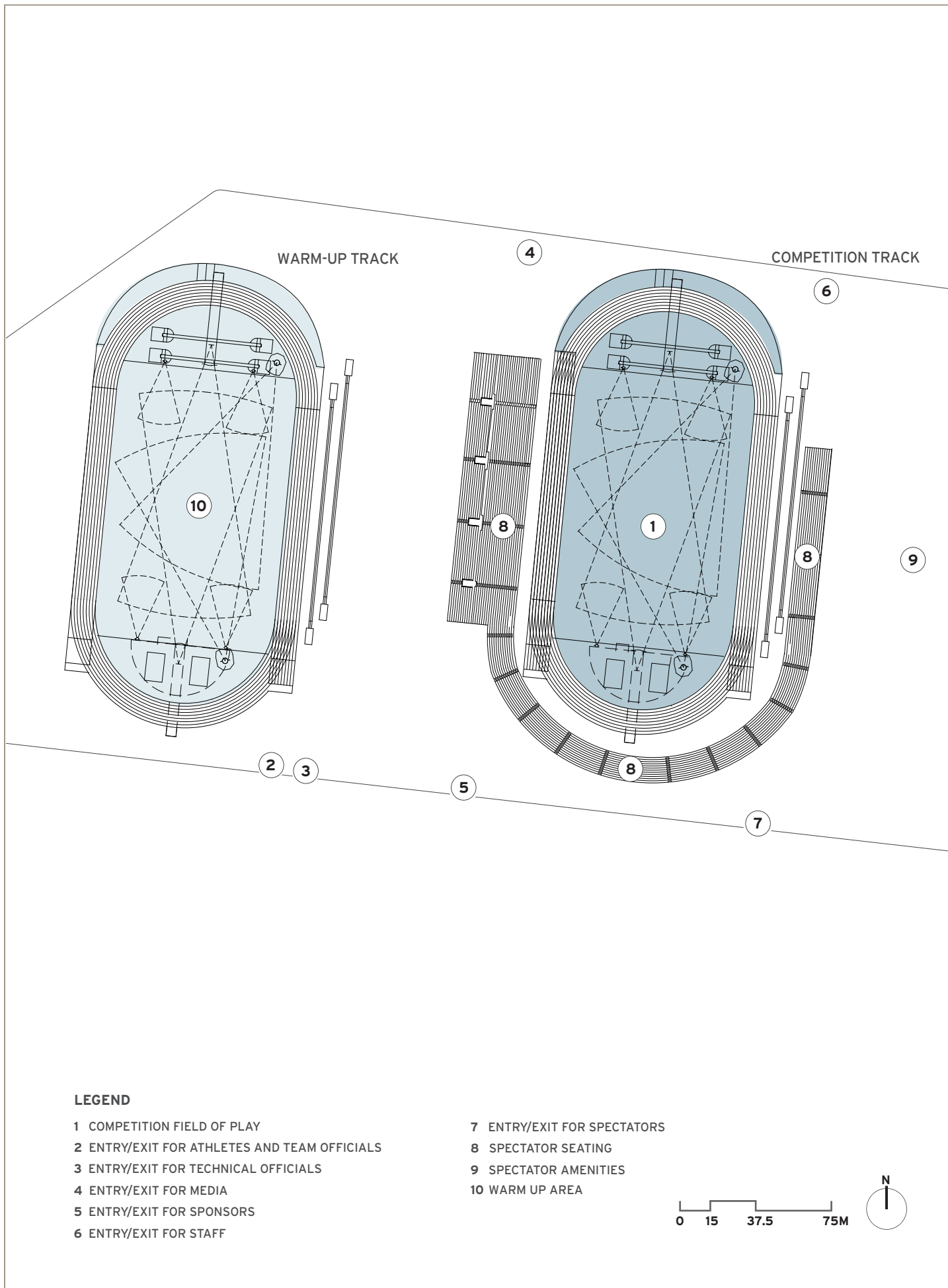

**LEGEND**

- |  |                             |
|--|-----------------------------|
| 1 COMPETITION FIELD OF PLAY                  | 7 ENTRY/EXIT FOR SPECTATORS |
| 2 ENTRY/EXIT FOR ATHLETES AND TEAM OFFICIALS | 8 SPECTATOR SEATING         |
| 3 ENTRY/EXIT FOR TECHNICAL OFFICIALS         | 9 SPECTATOR AMENITIES       |
| 4 ENTRY/EXIT FOR MEDIA                       | 10 WARM UP AREA             |
| 5 ENTRY/EXIT FOR SPONSORS                    |                             |
| 6 ENTRY/EXIT FOR STAFF                       |                             |





## SPORT: BADMINTON

### VENUE: Bill Crothers Secondary School

With a true focus on combining high performance sport excellence and academic achievement, the Bill Crothers Secondary School is a specialized sports school that brings together a significant array of sport facilities, including multiple large gymnasia, 400m athletics track, sports fields and strength and conditioning facilities.

This setting will be adapted to host the badminton competition and training venues, providing synergies for athletes and a multi-sport cluster with the Water Polo competition venue, less than one km away.



### > SPORT & VENUE SPECIFICATIONS

#### CURRENT STATUS

- Existing
- Built in 2008
- Current/Future Owner: York Region District School Board

#### VENUE HIGHLIGHTS

- Meets all International Federation specifications
- Seating Capacity: 2,500
- Distance from village: 27 minutes/29km
- Parking spaces: over 500

#### CURRENT AND POST GAMES USE

- The Bill Crothers Secondary School is an inclusive, learning environment that links excellence in education and athletics with a commitment to healthy, active living for all students. It serves as a catalyst for the development of health and physical education programming as well as sports and academic innovation.



### > COMPETITION SCHEDULE

JULY																		
Day	Thu	Fri	Sat	Sun	Mon	Tues	Wed	Thu	Fri	Sat	Sun	Mon	Tue	Wed	Thu	Fri	Sat	Sun
Date	9	10	11	12	13	14	15	16	17	18	19	20	21	22	23	24	25	26
Badminton														●	●	●	●	●

- Competition
- Finals (may include competitions on these days)

> COMPETITION SITE PLAN

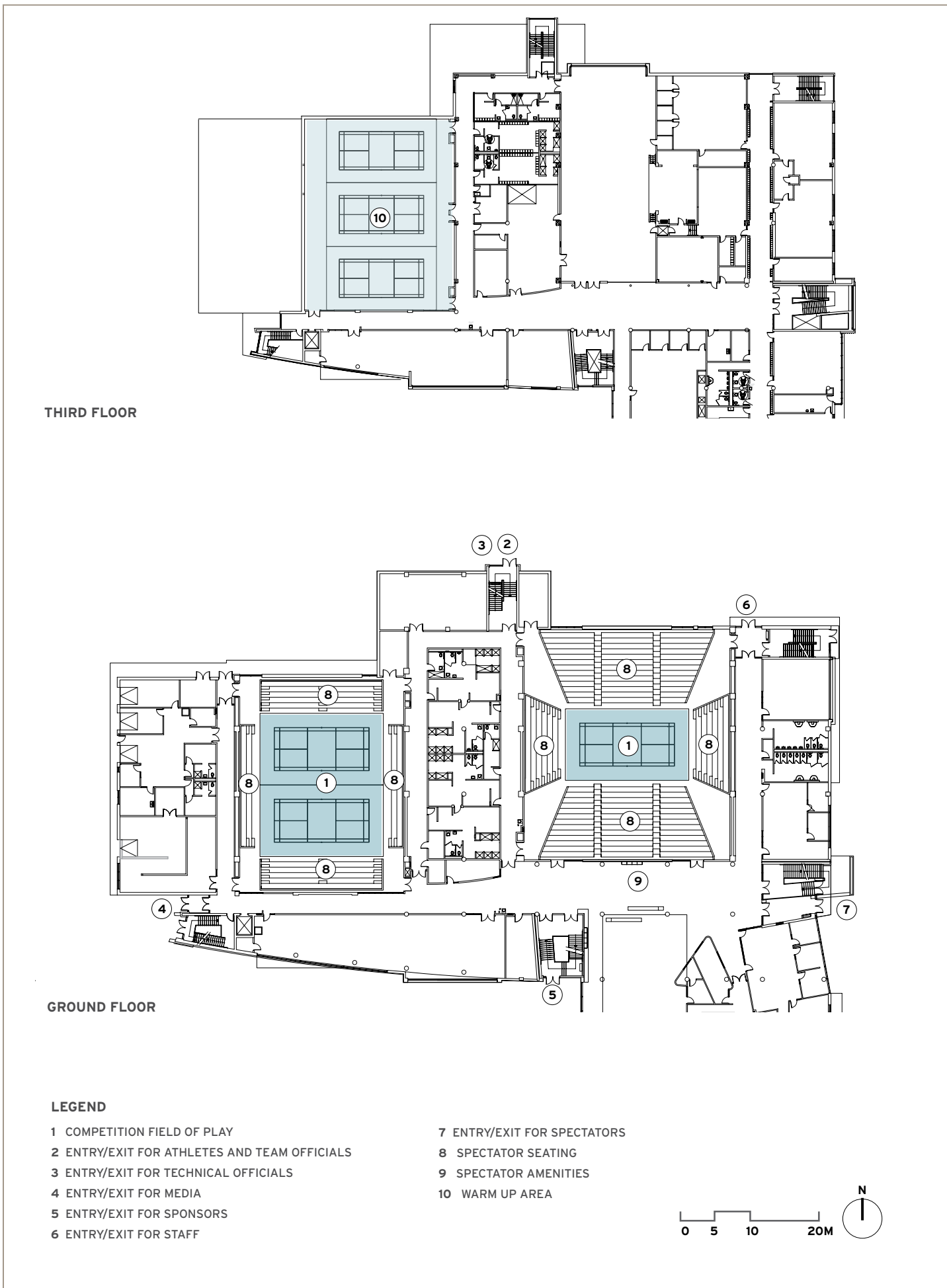



## SPORT: BASKETBALL

### VENUE: Air Canada Centre

Located in the heart of the city, the Air Canada Centre is a multi-purpose sport and entertainment venue, which provides a state of the art basketball venue for the Games located just minutes from the Pan American Village.

The expertise and the amenities, including significant broadcast and technological systems, provided to host the National Basketball Association's Toronto Raptors at this facility will be in full evidence as the Pan American Games athletes and officials take to the court.



### > SPORT & VENUE SPECIFICATIONS

#### CURRENT STATUS

- Existing
- Built in 1999
- Current/Future Owner: Maple Leaf Sports & Entertainment Ltd.

#### VENUE HIGHLIGHTS

- Meets all International Federation specifications
- Home of the National Basketball Association's Toronto Raptors
- Seating Capacity: 19,800
- Distance from village: 5 minutes/2km
- Parking spaces: 13,000

#### CURRENT AND POST GAMES USE

- Air Canada Centre is home to the Toronto Maple Leafs of the National Hockey League (NHL), and the Toronto Raptors Basketball Club of the National Basketball Association (NBA).
- Hosting Experience:
  - 2004 World Cup of Hockey
  - 2000 National Hockey League All-Star Game
  - 1999 - Present: Musicians: U2, Rolling Stones, Celine Dion, etc.



### > COMPETITION SCHEDULE

JULY																		
Day	Thu	Fri	Sat	Sun	Mon	Tues	Wed	Thu	Fri	Sat	Sun	Mon	Tue	Wed	Thu	Fri	Sat	Sun
Date	9	10	11	12	13	14	15	16	17	18	19	20	21	22	23	24	25	26
Basketball (W)								●	●	●	●	●						
Basketball (M)													●	●	●	●	●	

- Competition
- Finals (may include competitions on these days)

> COMPETITION SITE PLAN

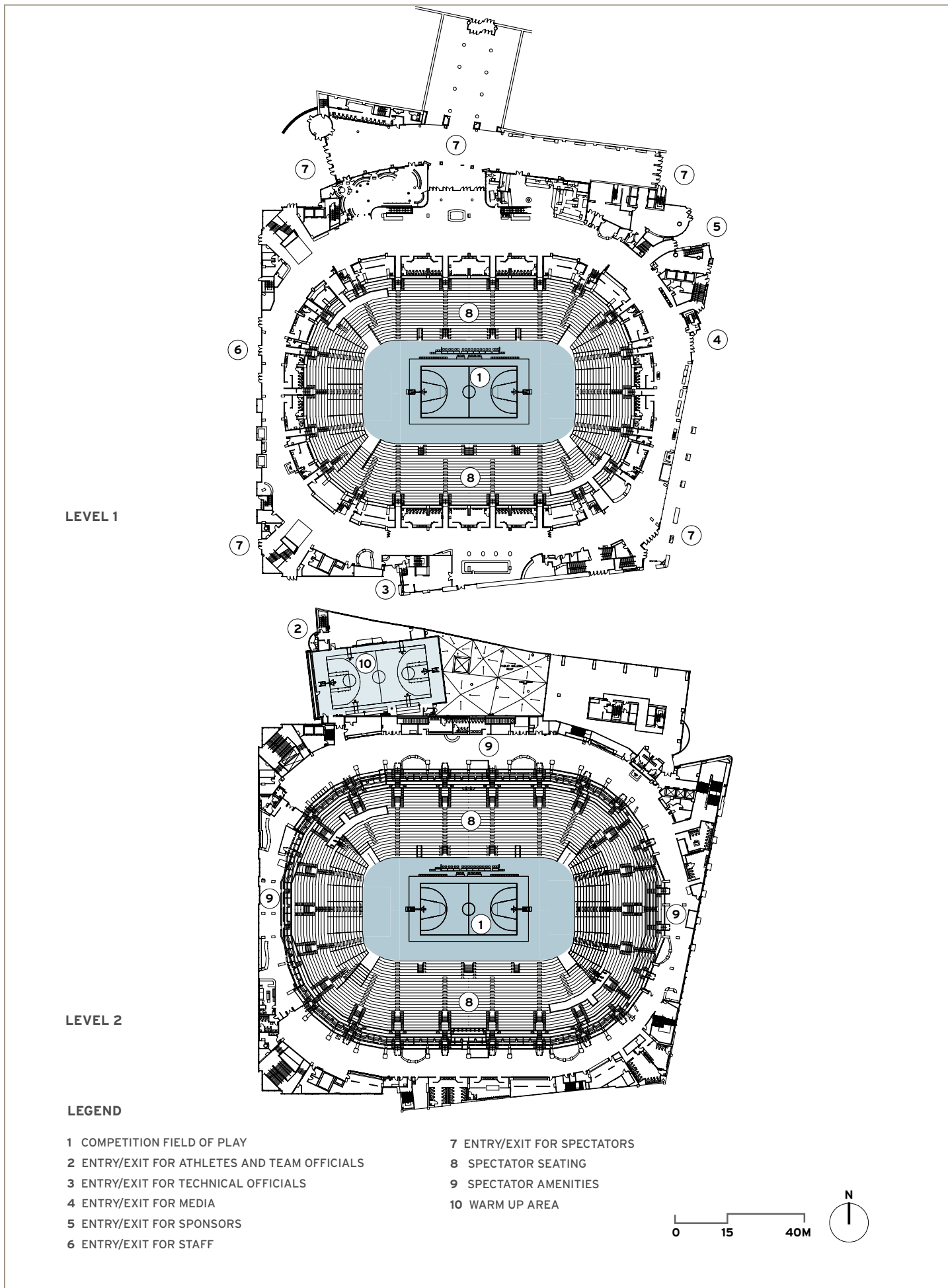



## SPORT: BOXING

### VENUE: General Motors Centre

The General Motors Centre is a premier sports and entertainment facility providing an ideal atmosphere for fans to cheer sports teams and athletes as well as enjoy world-class concerts and events.

Within the General Motors Centre and adjacent to the main spectator arena seating of 5,500 is a secondary arena to house the training rings. This will provide athletes and officials with a compact facility combining an exciting competitive venue with the convenience of a short walk to the training areas outfitted to meet or exceed the AIBA specifications.



### > SPORT & VENUE SPECIFICATIONS

#### CURRENT STATUS

- Existing
- Built in 2006
- Current/Future Owner: City of Oshawa

#### VENUE HIGHLIGHTS

- Meets all International Federation specifications
- Seating Capacity: 5,500
- Distance from village: 40 minutes/59km
- Parking spaces: over 1,000

#### CURRENT AND POST GAMES USE

- A focal point for the entire community and a venue that attracts top national and international artists and live events, and home to the Ontario Hockey League's (OHL) Oshawa Generals.
- Hosting Experience:
  - 2009 OHL Top Prospect Game
  - 2009 Harlem Globetrotters
  - 2006 - Present: OHL's Oshawa Generals
  - 2006 - Present: Musicians: Bob Dylan, INXS, Tom Jones
  - 2006 OHL's ADT Canada Russia Hockey Series



### > COMPETITION SCHEDULE

JULY																		
Day	Thu	Fri	Sat	Sun	Mon	Tues	Wed	Thu	Fri	Sat	Sun	Mon	Tue	Wed	Thu	Fri	Sat	Sun
Date	9	10	11	12	13	14	15	16	17	18	19	20	21	22	23	24	25	26
Boxing								●	●	●	●	●	●	●	●	●	●	

- Competition
- Finals (may include competitions on these days)

> COMPETITION SITE PLAN

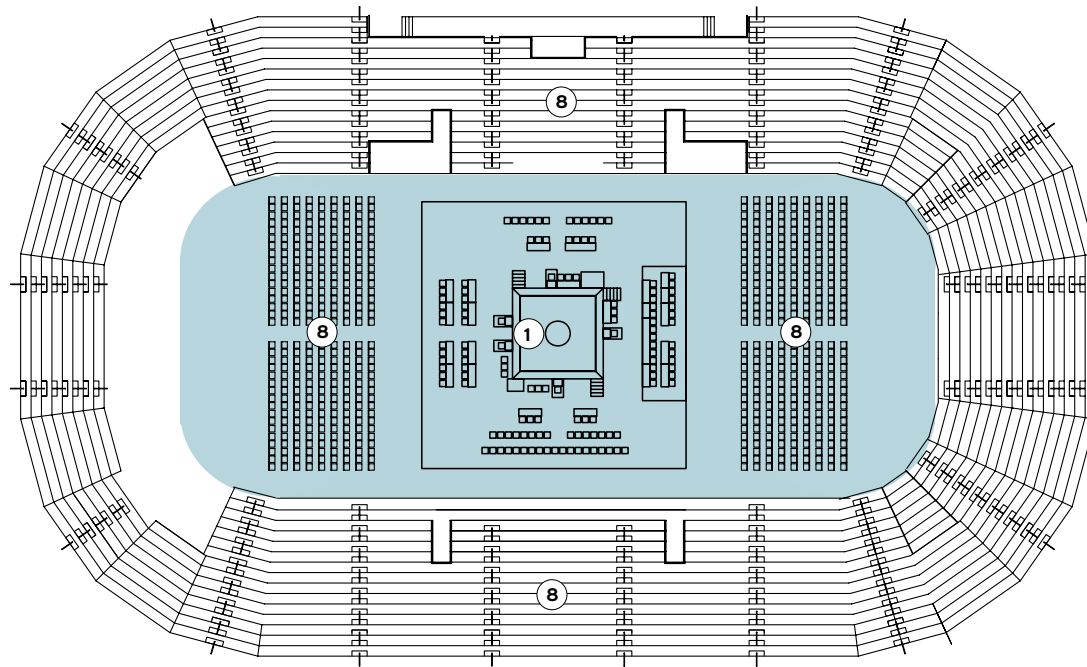
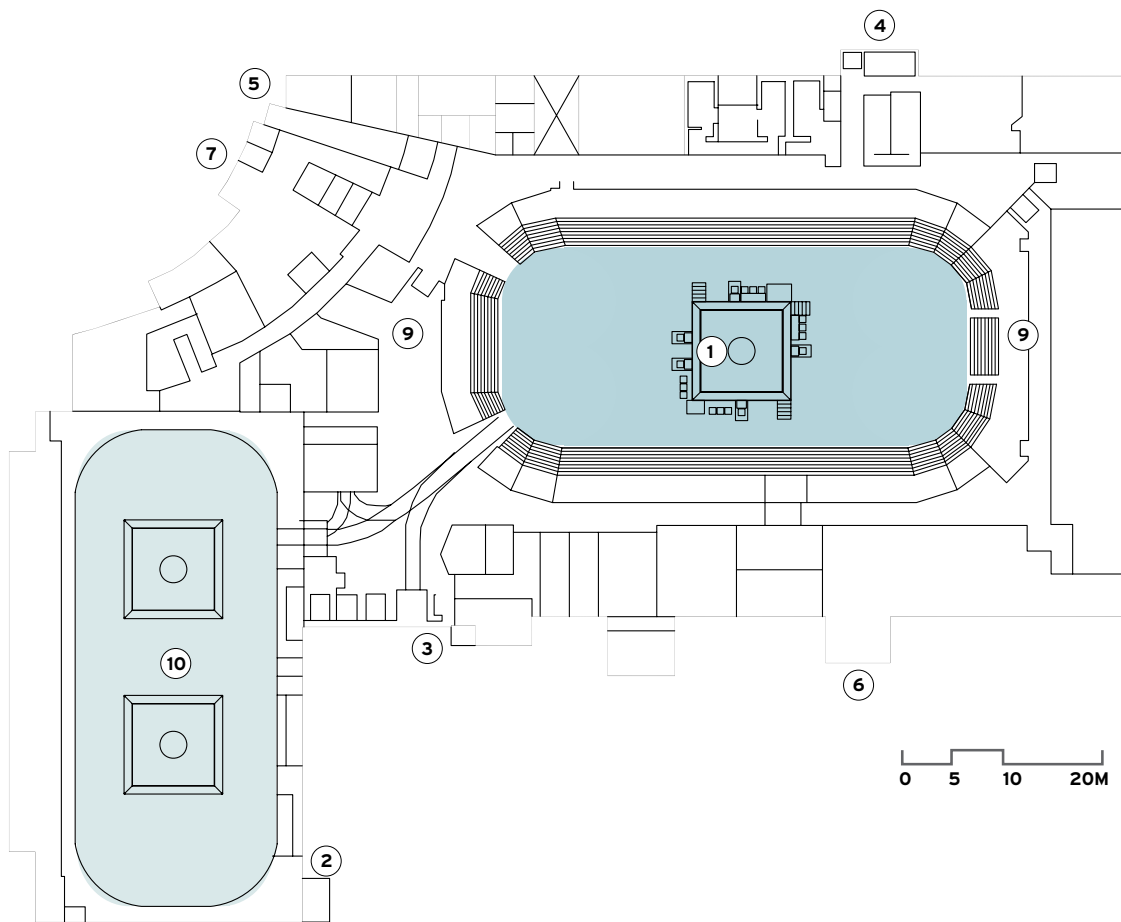

**LEGEND**

- |  |                             |
|--|-----------------------------|
| 1 COMPETITION FIELD OF PLAY                  | 7 ENTRY/EXIT FOR SPECTATORS |
| 2 ENTRY/EXIT FOR ATHLETES AND TEAM OFFICIALS | 8 SPECTATOR SEATING         |
| 3 ENTRY/EXIT FOR TECHNICAL OFFICIALS         | 9 SPECTATOR AMENITIES       |
| 4 ENTRY/EXIT FOR MEDIA                       | 10 WARM UP AREA             |
| 5 ENTRY/EXIT FOR SPONSORS                    |                             |
| 6 ENTRY/EXIT FOR STAFF                       |                             |

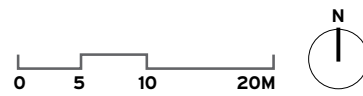



**SPORT:**  
**CANOE/KAYAK**  
**SPRINT**

**VENUE: Welland International Flatwater Centre**

The Welland International Flatwater Centre is located on the former Welland Canal, developed to bypass the magnificent Niagara Falls and create an in-land shipping channel through the Eastern part of Canada.

With its controlled and protected waters, the venue provides pristine water conditions and consistent depth throughout its racing lanes that will provide excellent racing conditions and a unmatched venue for Canoe/Kayak Sprint.

To ensure athletes can perform at optimum levels, and based on the advice of the International Sport Federation (Canoe/Kayak) we will make available athlete and team official accommodations within 20 minutes of the competitive venue.



**> SPORT & VENUE SPECIFICATIONS**

**CURRENT STATUS**

- Existing / Retrofit
- Construction Status: Completed by 2014
- Current/Future owner: City of Welland

**VENUE HIGHLIGHTS**

- Meets all International Federation specifications
- Seating Capacity: 2,500
- Distance from village: 99 minutes/134km
- Parking spaces: over 1,000

**CURRENT AND POST GAMES USE**

- Currently plays host to numerous championships each year in addition to being a training facility for recreational and competitive paddlers.
- As a legacy project for the Games, this facility will further evolve as a national training centre, capable of hosting major national and international events.
- Hosting Experience:
  - 2009 Commonwealth Rowing Development Camp
  - 2007 International Dragon Boat Federation Corporation and Community Championships
  - National and Provincial Canoe, Kayak and Rowing Events



**> COMPETITION SCHEDULE**

JULY																		
Day	Thu	Fri	Sat	Sun	Mon	Tues	Wed	Thu	Fri	Sat	Sun	Mon	Tue	Wed	Thu	Fri	Sat	Sun
Date	9	10	11	12	13	14	15	16	17	18	19	20	21	22	23	24	25	26
VENUE: WELLAND INTERNATIONAL FLAT-WATER CENTRE																		
Canoe/Kayak Sprint			●	●														

● Finals (may include competitions on these days)

> COMPETITION SITE PLANS

WELLAND INTERNATIONAL FLATWATER CENTRE (WIFC) - CANOE/KAYAK - SPRINT

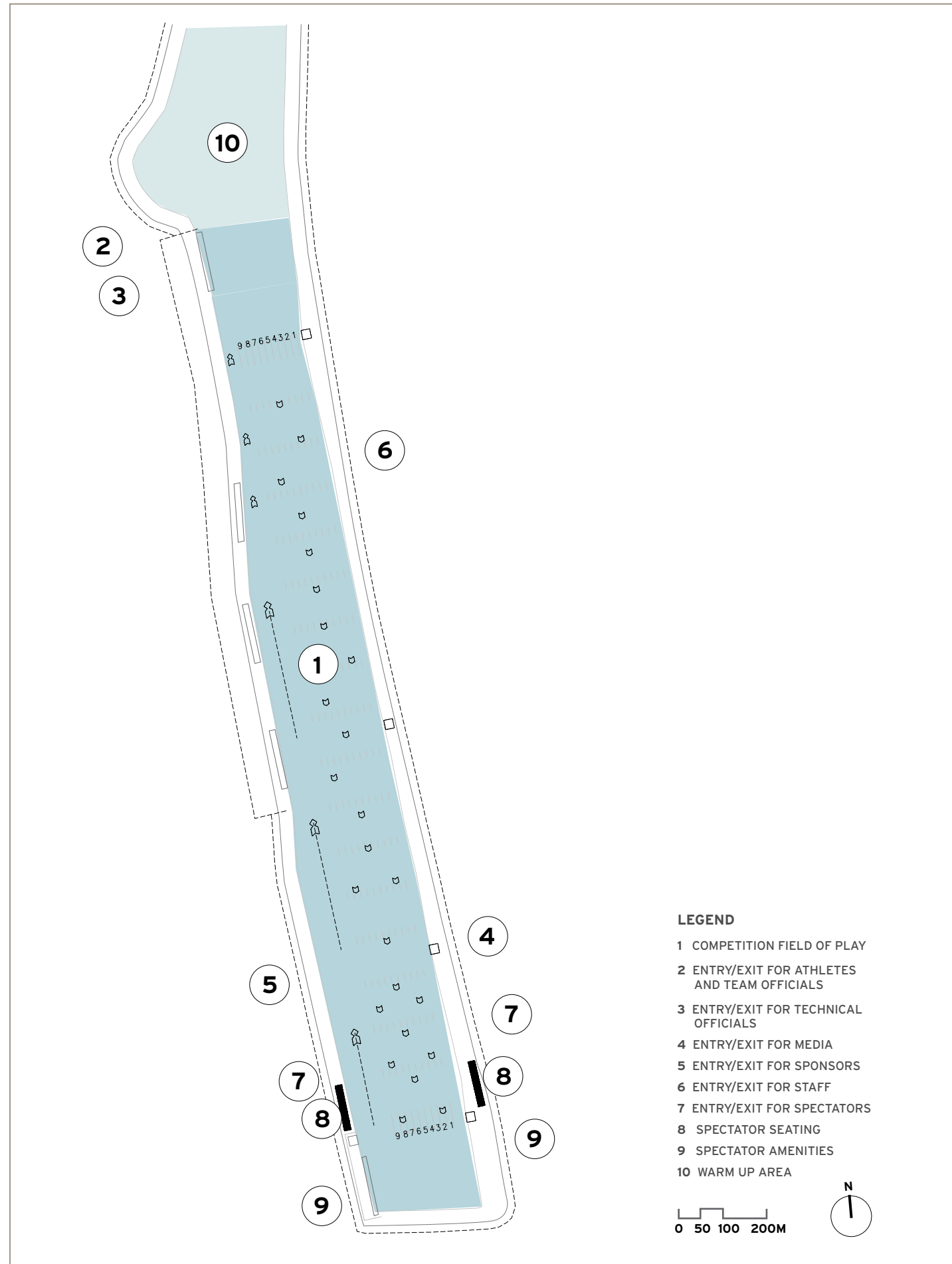

MINDEN WILD WATER PRESERVE - CANOE/KAYAK - SLALOM

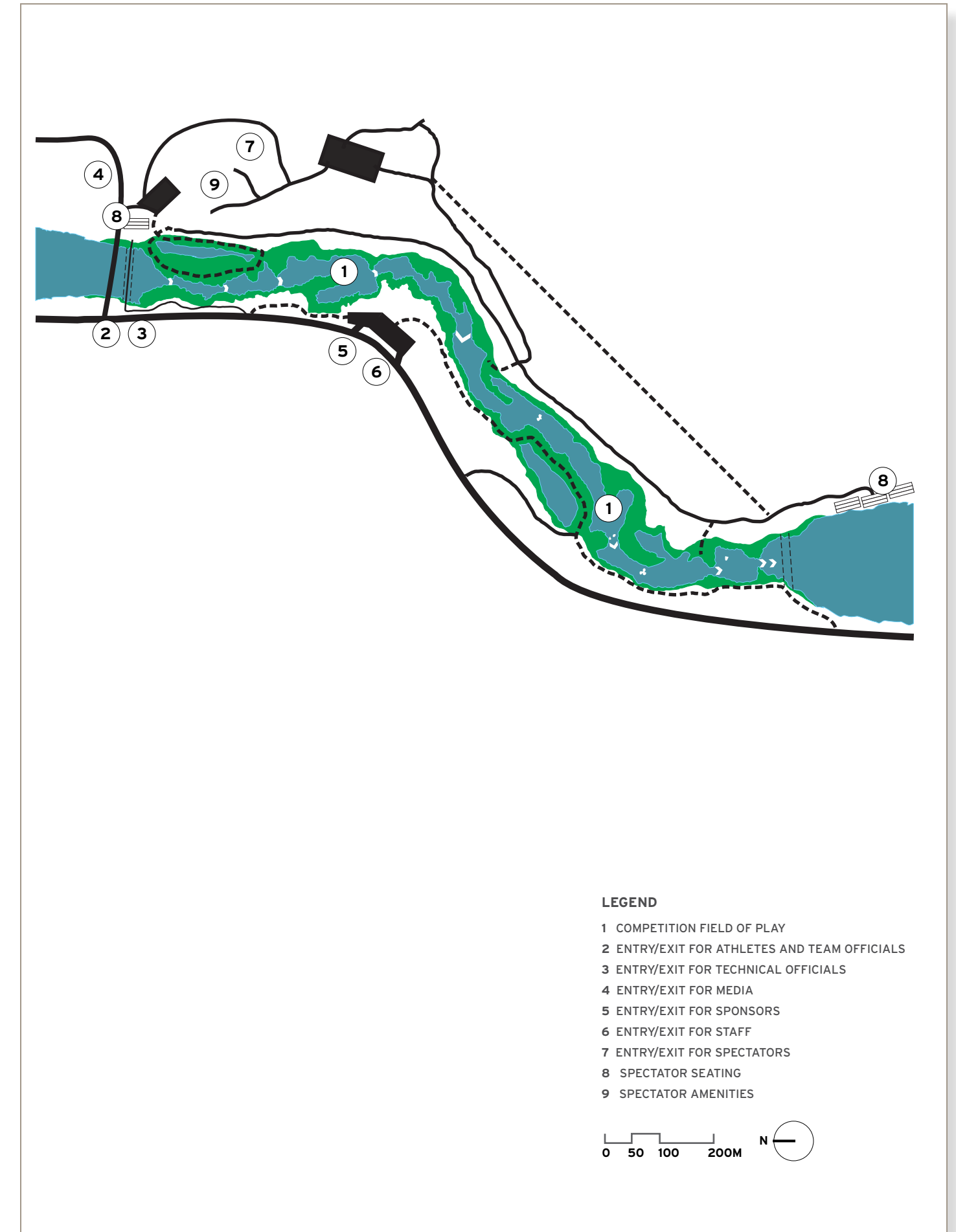



**SPORT:**  
**CANOE/KAYAK**  
**SLALOM**

**VENUE: Minden Wild Water Preserve**

The Minden Wildwater Preserve is a natural watercourse with international level competition experience that will be enhanced to provide athletes and spectators with a competition site that combines the serenity of this peaceful area and the raw strength of the raging whitewater.

As the leading sites for slalom in the region, the Games will provide the opportunity to further entrench the site as a high-level training and competitive centre for the development of the sport.

To ensure athletes can perform at optimum levels, and based on the advice of the International Sport Federation (Canoe Kayak) we will make available athlete and team official accommodations within 20 minutes of the competitive venue.

> **SPORT & VENUE SPECIFICATIONS**

CURRENT STATUS
<ul style="list-style-type: none"> <li>Existing</li> <li>Built in 1970</li> <li>Current/Future owner: Whitewater Ontario</li> </ul>
VENUE HIGHLIGHTS
<ul style="list-style-type: none"> <li>Meets all International Federation specifications</li> <li>Seating Capacity: 2,500</li> <li>Distance from village: 133 minutes / 197 km</li> <li>Parking spaces: over 500</li> </ul>
CURRENT AND POST GAMES USE
<ul style="list-style-type: none"> <li>The Minden Wild Water Preserve currently hosts recreational paddlers as well as major national competitions.</li> <li>Hosting Experience:               <ul style="list-style-type: none"> <li>2008 North American and U.S. National Open Canoe Slalom Championships</li> <li>1997/1993/1991 World Cup Slalom Events</li> </ul> </li> </ul>



> **COMPETITION SCHEDULE**

JULY																		
Day	Thu	Fri	Sat	Sun	Mon	Tues	Wed	Thu	Fri	Sat	Sun	Mon	Tue	Wed	Thu	Fri	Sat	Sun
Date	9	10	11	12	13	14	15	16	17	18	19	20	21	22	23	24	25	26
VENUE: MINDEN WILD WATER PRESERVE																		
Canoe/Kayak Slalom			•	•														

• Finals (may include competitions on these days)



**SPORT:**  
**CYCLING**

**VENUES:**

- A | PAN AMERICAN VELODROME - TRACK CYCLING**
- B | EXHIBITION PLACE - ROAD CYCLING**
- C | PAN AMERICAN BMX COURSE - BMX CYCLING**
- D | HARDWOOD SKI AND BIKE - MOUNTAIN BIKING**

Adjacent to the new Pan American Stadium, the Pan American Velodrome is a facility that will be a significant legacy of the Games, as it will represent Canada's only indoor velodrome meeting the international specification at 250m. As a result, this facility will become a national training centre and provide opportunities to host significant national and international competitions.

During the Games, its close proximity to the Athletics and Volleyball venues will create a significant cluster of venues for three important sports within 1km of each other making it easy for athletes and spectators to witness sport excellence at its best.



> **SPORT & VENUE SPECIFICATIONS**

**A | PAN AMERICAN VELODROME**

CURRENT STATUS
<ul style="list-style-type: none"> <li>New Build</li> <li>Construction Status: Completed by 2014</li> <li>Current/Future owner: City of Hamilton</li> </ul>
VENUE HIGHLIGHTS
<ul style="list-style-type: none"> <li>Meets all International Federation specifications</li> <li>Seating Capacity: 3,500</li> <li>Distance from village: 45 minutes / 68 km</li> <li>Parking spaces: 8,400</li> </ul>
CURRENT AND POST GAMES USE
<ul style="list-style-type: none"> <li>National training centre and host site for future national and international events.</li> </ul>

> **COMPETITION SCHEDULE**

JULY																		
Day	Thu	Fri	Sat	Sun	Mon	Tues	Wed	Thu	Fri	Sat	Sun	Mon	Tue	Wed	Thu	Fri	Sat	Sun
Date	9	10	11	12	13	14	15	16	17	18	19	20	21	22	23	24	25	26
VENUE: PAN AMERICAN VELODROME																		
Track														•	•	•	•	
VENUE: EXHIBITION PLACE - ROAD CYCLING																		
Road				•							•							
VENUE: ONTARIO PLACE - PAN AMERICAN BMX COURSE																		
BMX																	•	
VENUE: HARDWOOD SKI AND BIKE - MOUNTAIN BIKING																		
Mountain Bike					•													

• Competition • Finals (may include competitions on these days)



> COMPETITION SITE PLANS

A | PAN AMERICAN VELODROME - TRACK CYCLING

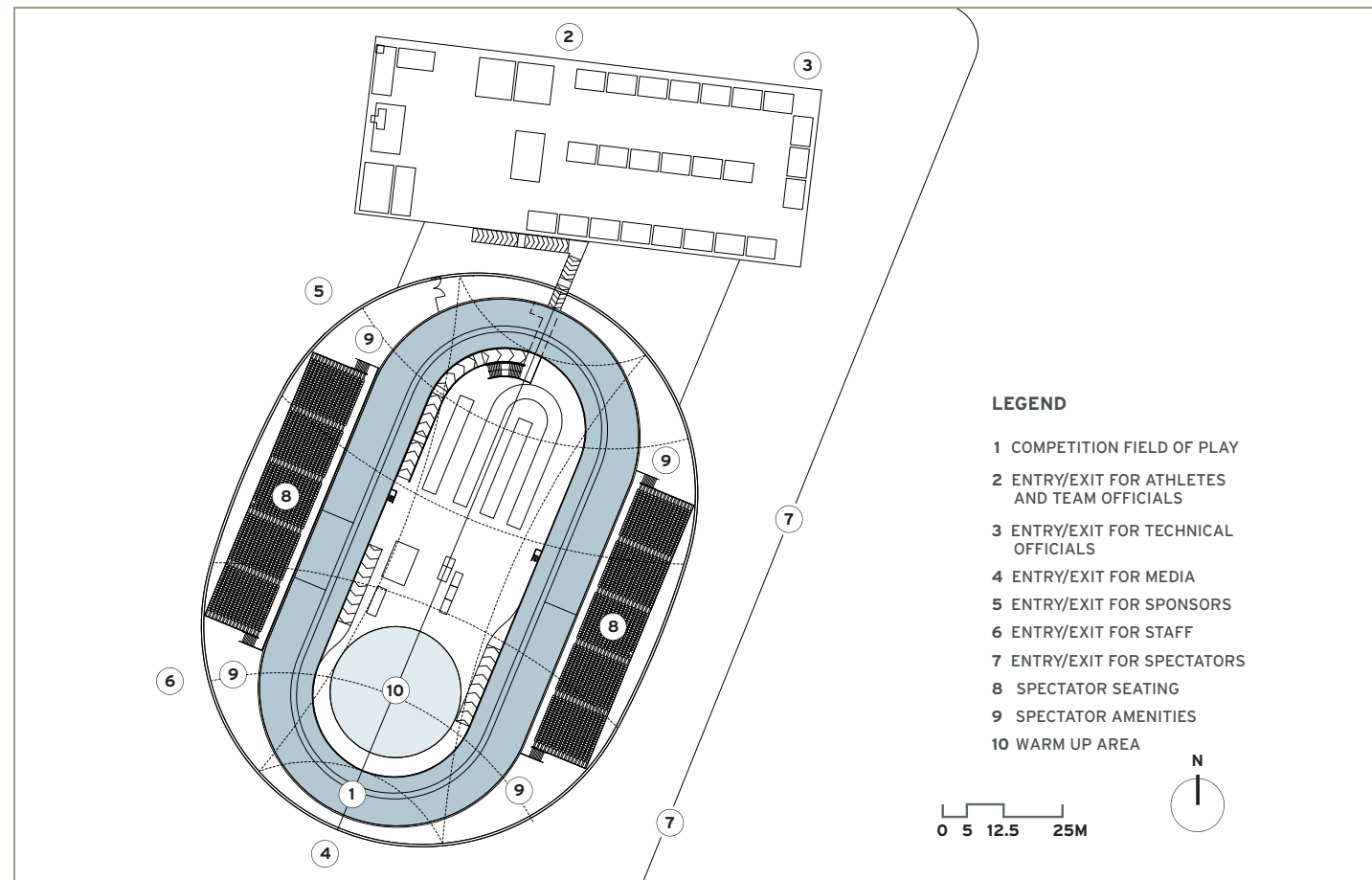

B | EXHIBITION PLACE - ROAD CYCLING



C | PAN AMERICAN BMX COURSE - BMX CYCLING

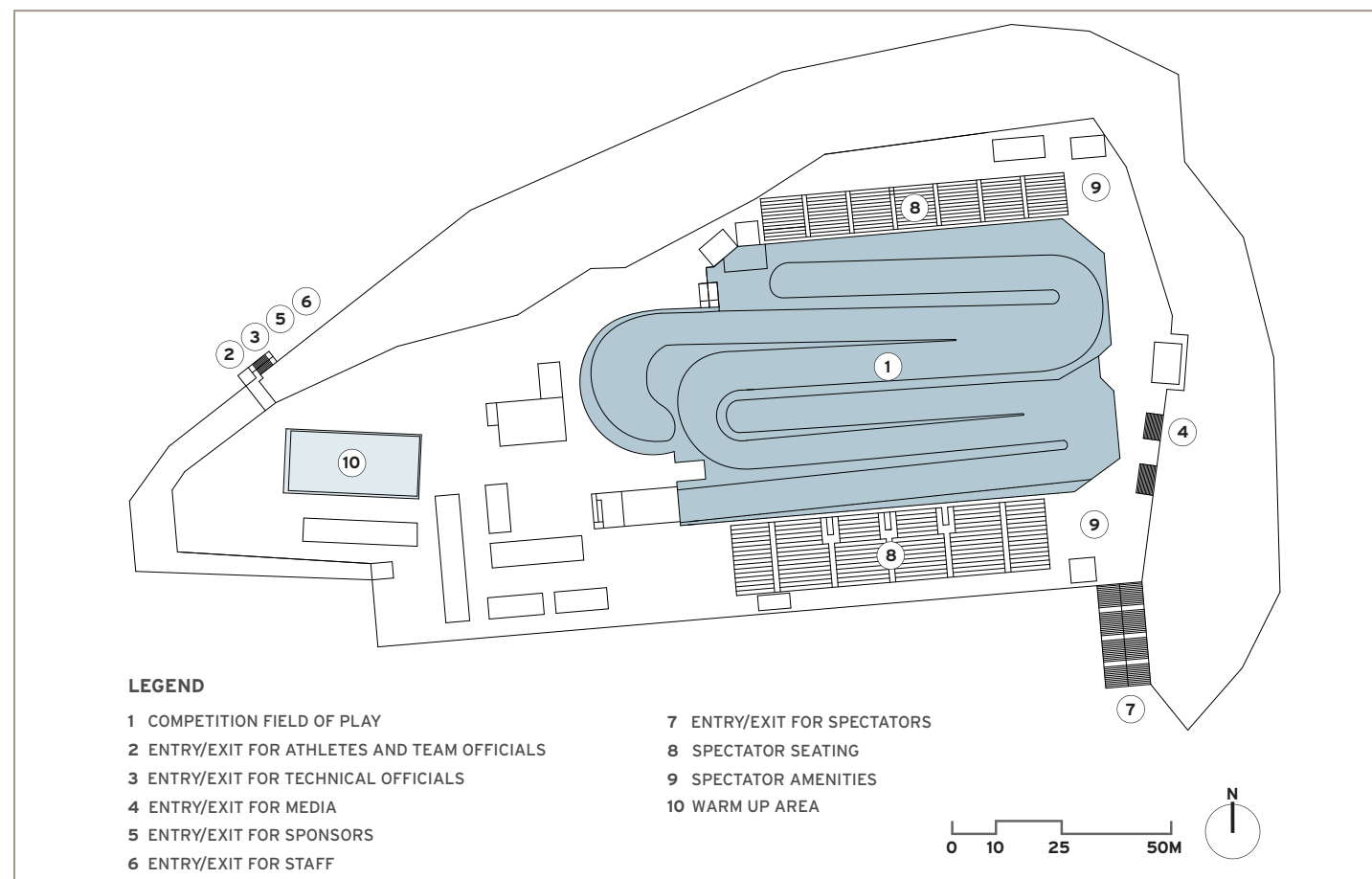

D | HARDWOOD SKI AND BIKE - MOUNTAIN CYCLING

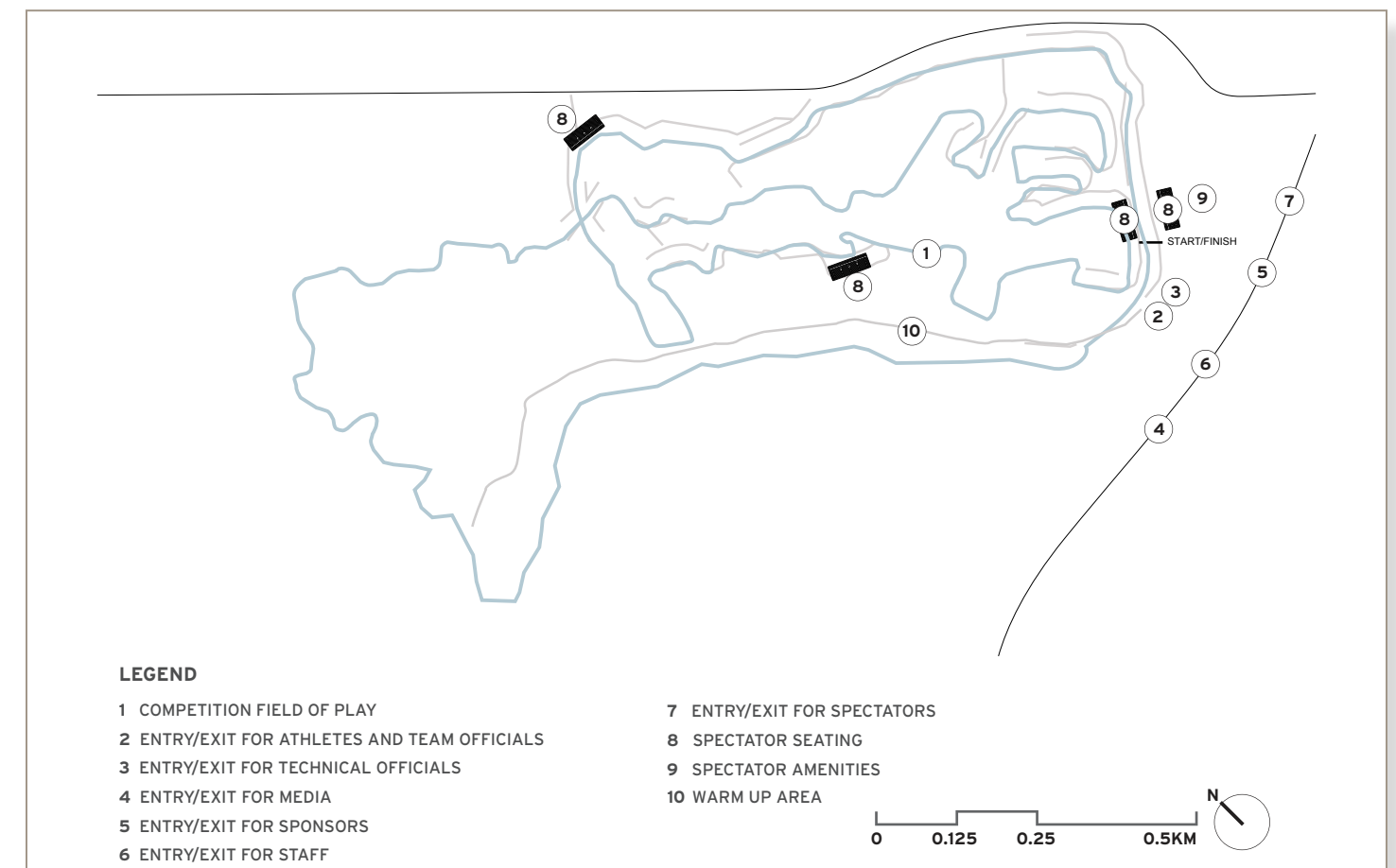

**B | EXHIBITION PLACE - ROAD CYCLING**

The Pan American Road Course will start and finish at Exhibition Place, the location of a significant cluster of sports for the Games and minutes from the Pan American Village.

The course will begin on the IndyCar Series Course on the grounds of Exhibition Place, follow the picturesque waterfront of the City of Toronto, and then take competitors through Toronto's diverse neighbourhoods and more challenging hillside areas.

Sports competing at Exhibition Place also include BMX (Cycling), Gymnastics, Beach Volleyball, Triathlon, Football, and Handball.

CURRENT STATUS
<ul style="list-style-type: none"> <li>Existing</li> <li>Current/future owner: City of Toronto</li> </ul>
VENUE HIGHLIGHTS
<ul style="list-style-type: none"> <li>Meets all International Federation specifications</li> <li>Seating Capacity: over 5,000</li> <li>Distance from village: 5 minutes / 6km (Start/Finish Area)</li> <li>Parking spaces: 7,000</li> </ul>
CURRENT AND POST GAMES USE
<ul style="list-style-type: none"> <li>The 197 acre Exhibition Place is a mixed-use property on the Toronto shore of Lake Ontario, featuring expo, trade, and banquet centres, theater and music buildings, parkland, sports facilities, and a number of civic, provincial, and national historic sites.</li> </ul>



**C | PAN AMERICAN BMX COURSE - BMX CYCLING**

A new legacy development as part of the Games, the Pan American BMX Course at Ontario Place will be designed to create a challenging course with thrilling jumps, banked curves and obstacles.

Set on the Toronto Waterfront, the BMX competition will be an exciting event that will generate significant interest as one of the newest sports on the program.

Cycling BMX will be part of a significant cluster of sport venues around Exhibition Place, including Karate, Gymnastics, Beach Volleyball, Road Cycling, Triathlon, Football, and Handball.

CURRENT STATUS
<ul style="list-style-type: none"> <li>New Build</li> <li>Construction Status: Completed by 2014</li> <li>Current/Future owner: Province of Ontario</li> </ul>
VENUE HIGHLIGHTS
<ul style="list-style-type: none"> <li>Meets all International Federation specifications</li> <li>Seating Capacity: 5,000</li> <li>Distance from village: 5 minutes / 6km</li> <li>Parking spaces: 7,000</li> </ul>
CURRENT AND POST GAMES USE
<ul style="list-style-type: none"> <li>As a legacy development of the Games, this venue is expected to become a national training centre and provide a venue to host national and international competitions.</li> </ul>



**D | HARDWOOD SKI AND BIKE - MOUNTAIN BIKING**

Hardwood Ski and Bike is Ontario's foremost mountain biking area and has 36 km of doubletrack and 45 km of singletrack. As a National Mountain Bike Development Centre it includes all the amenities required to host a major international competition.

As an experienced competitive venue, the site will provide competing athletes with a challenging technical course in a natural setting sure to thrill all participants and spectators.

CURRENT STATUS
<ul style="list-style-type: none"> <li>Existing</li> <li>Current/Future Owner: Hardwood Ski and Bike</li> </ul>
VENUE HIGHLIGHTS
<ul style="list-style-type: none"> <li>Meets all International Federation specifications</li> <li>Seating Capacity: 5,000</li> <li>Distance from village: 89 minutes / 130 km</li> <li>Parking spaces: over 1,000</li> </ul>
CURRENT AND POST GAMES USE
<ul style="list-style-type: none"> <li>Hardwood Ski and Bike is a multi-sport adventure centre offering beautiful, rolling trails through hardwood and pine forests for mountain biking, hiking, walking or running, as well as nordic skiing in the winter.</li> <li>Hosting Experience:             <ul style="list-style-type: none"> <li>1995 - Present: Annual Canada Mountain Biking Cup (UCI)</li> </ul> </li> </ul>



**SPORT: EQUESTRIAN**

**VENUE: Caledon Equestrian Park**

The Caledon Equestrian Park, on the hills of the Oak Ridges Moraine, will be the site of the equestrian competition. The rolling terrain, pastoral farmland and enchanting small towns provide a unique counterpoint to the vibrant energy of Toronto.

This venue will be a legacy for local and national equestrian communities, by providing a world-class facility for training and hosting future national and international competitions. Within the equestrian community, the soil at the Park is noted as having some of the best footing conditions in the world due to the ground consisting of firm sand, which drains immediately.



**> SPORT & VENUE SPECIFICATIONS**

CURRENT STATUS
<ul style="list-style-type: none"> <li>Existing / Retrofit</li> <li>Built in 1986</li> <li>Current/Future owner: Equestrian Management Group</li> </ul>
VENUE HIGHLIGHTS
<ul style="list-style-type: none"> <li>Meets all International Federation specifications</li> <li>Seating Capacity: 5,000</li> <li>Distance from village: 45 minutes / 59 km</li> <li>Parking spaces: over 1,000</li> </ul>
CURRENT AND POST GAMES USE
<ul style="list-style-type: none"> <li>Currently, the venue is one of Canada's best equestrian sites hosting major events. Following the Games, the venue would continue to operate as a world class training and event centre.</li> <li>Hosting Experience:             <ul style="list-style-type: none"> <li>20 World Cup Qualifiers</li> <li>4 Pan American National Team Selection Trials</li> <li>2 Olympic National Team Selection Trials</li> <li>60 major National Grand Prix events</li> </ul> </li> </ul>



**> COMPETITION SCHEDULE**

JULY																		
Day	Thu	Fri	Sat	Sun	Mon	Tues	Wed	Thu	Fri	Sat	Sun	Mon	Tue	Wed	Thu	Fri	Sat	Sun
Date	9	10	11	12	13	14	15	16	17	18	19	20	21	22	23	24	25	26
Dressage			●	●	●	●												
3-day eventing										●	●	●						
Show Jumping															●	●	●	●

● Competition ● Finals (may include competitions on these days)



> COMPETITION SITE PLAN

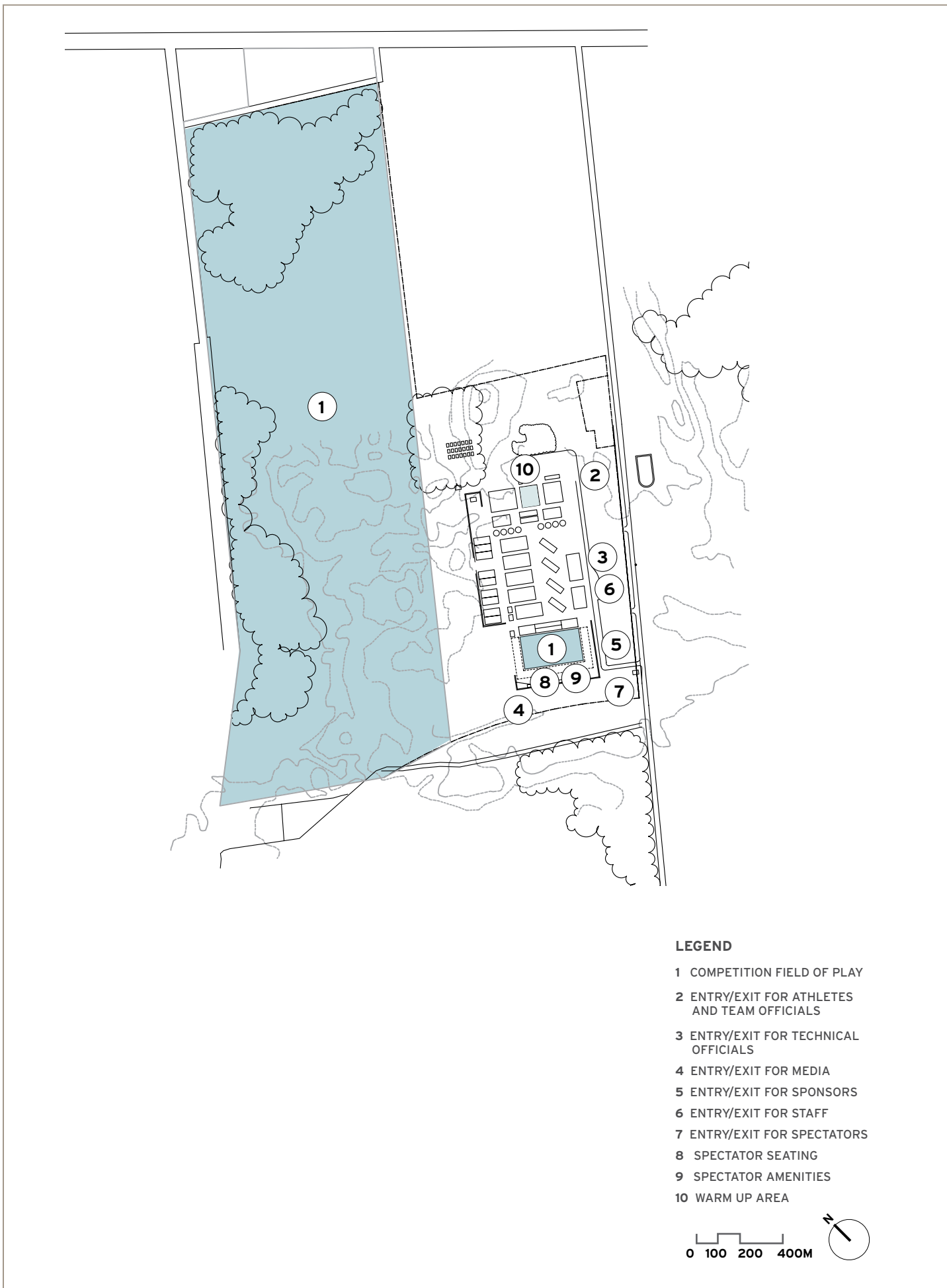



## SPORT: FENCING

### VENUE: Canadian Sport Institute Ontario

The Canadian Sport Institute Ontario (CSIO) will be part of a 28,000 m<sup>2</sup> facility that will include the Pan American Aquatics Centre, a significant multi-sport field house and a high performance training centre for summer sports.

Fencing will be held in the fieldhouse component of the CSIO, providing athletes with a leading edge competitive venue and access to the flagship facility of the 2015 Pan American Games.



### > SPORT & VENUE SPECIFICATIONS

#### CURRENT STATUS

- New build
- Construction Status: Completed by 2014
- Current/Future owner:  
University of Toronto/City of Toronto

#### VENUE HIGHLIGHTS

- Meets all International Federation specifications
- Seating Capacity: 3,000
- Distance from village: 22 minutes/29km
- Parking spaces: over 3,000

#### CURRENT AND POST GAMES USE

- The facility will link together community sport and recreation use, competitive use by university and sports clubs, a national training centre for Canada's top athletes and provide a venue to host the world for major national and international competitions.



### > COMPETITION SCHEDULE

JULY																		
Day	Thu	Fri	Sat	Sun	Mon	Tues	Wed	Thu	Fri	Sat	Sun	Mon	Tue	Wed	Thu	Fri	Sat	Sun
Date	9	10	11	12	13	14	15	16	17	18	19	20	21	22	23	24	25	26
Fencing										•	•	•	•	•	•	•	•	

- Finals (may include competitions on these days)

> COMPETITION SITE PLAN

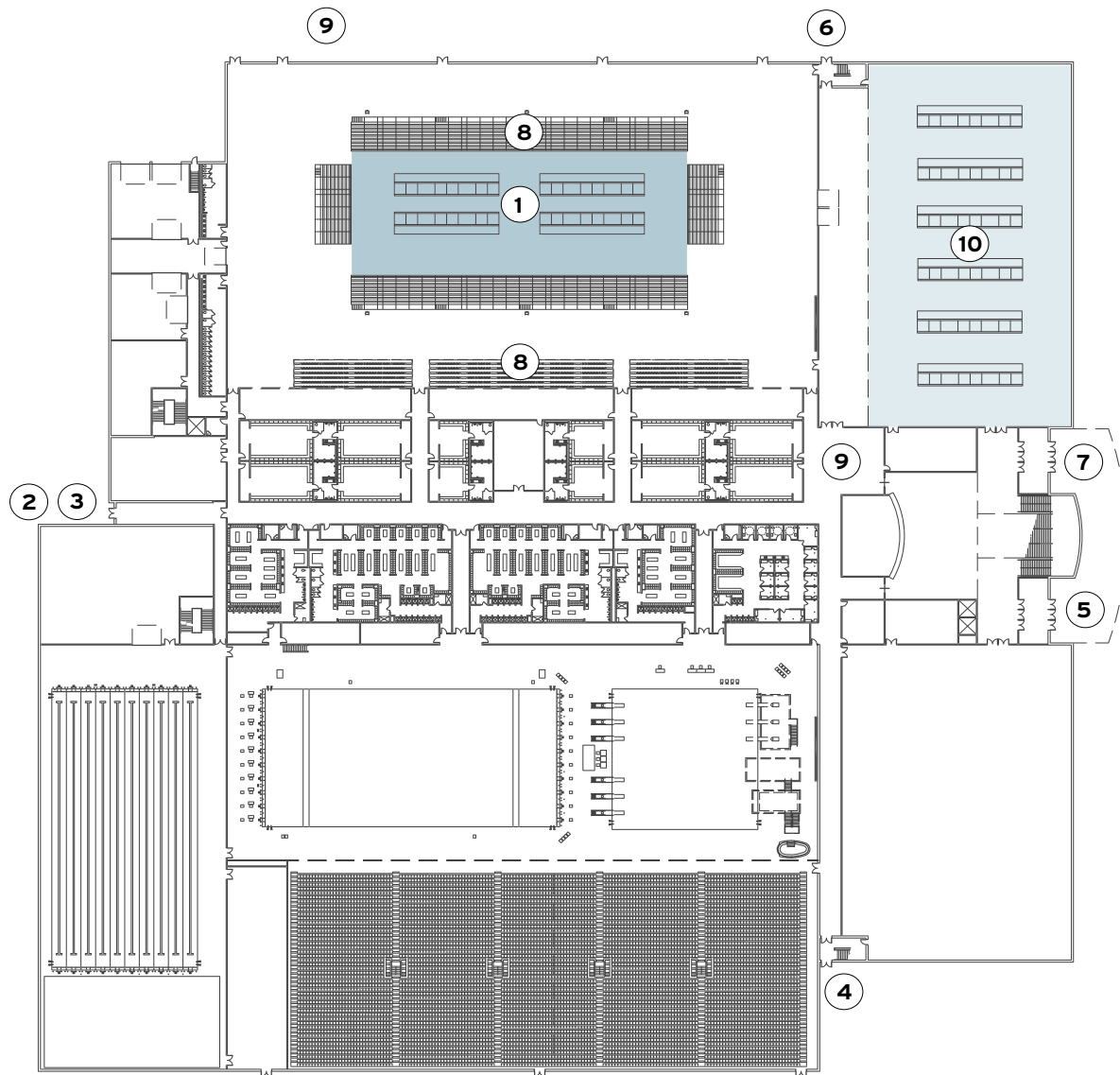

**LEGEND**

- 1 COMPETITION FIELD OF PLAY
- 2 ENTRY/EXIT FOR ATHLETES AND TEAM OFFICIALS
- 3 ENTRY/EXIT FOR TECHNICAL OFFICIALS
- 4 ENTRY/EXIT FOR MEDIA
- 5 ENTRY/EXIT FOR SPONSORS
- 6 ENTRY/EXIT FOR STAFF
- 7 ENTRY/EXIT FOR SPECTATORS
- 8 SPECTATOR SEATING
- 9 SPECTATOR AMENITIES
- 10 WARM UP AREA

0 10 20 40M





## SPORT: FIELD HOCKEY

### VENUE: Pan American Field Hockey Centre

The Pan American Field Hockey Centre is a new development that will provide a key sport infrastructure legacy to the community which will assist in building the profile of field hockey in the province.

As Ontario's first dedicated international field hockey venue, including two fields meeting international specifications, it will become a centre of excellence for the national and provincial teams as well as provide a dedicated site that will host all levels of the game from international events to grass root leagues and tournaments.

### > SPORT & VENUE SPECIFICATIONS

#### CURRENT STATUS

- New build
- Construction Status: Completed by 2014
- Current/Future Owner: University of Toronto

#### VENUE HIGHLIGHTS

- Meets all International Federation specifications
- Seating Capacity: 5,000
- Distance from village: 5 minutes/5km
- Parking spaces: over 3,000

#### CURRENT AND POST GAMES USE

- The Pan American Field Hockey Centre will become a legacy by providing a world-class facility for training and hosting future national and international competitions.



### > COMPETITION SCHEDULE

JULY																		
Day	Thu	Fri	Sat	Sun	Mon	Tues	Wed	Thu	Fri	Sat	Sun	Mon	Tue	Wed	Thu	Fri	Sat	Sun
Date	9	10	11	12	13	14	15	16	17	18	19	20	21	22	23	24	25	26
Field Hockey (W)							●		●		●		●			●		
Field Hockey (M)								●		●		●		●			●	

- Competition
- Finals (may include competitions on these days)

> COMPETITION SITE PLAN

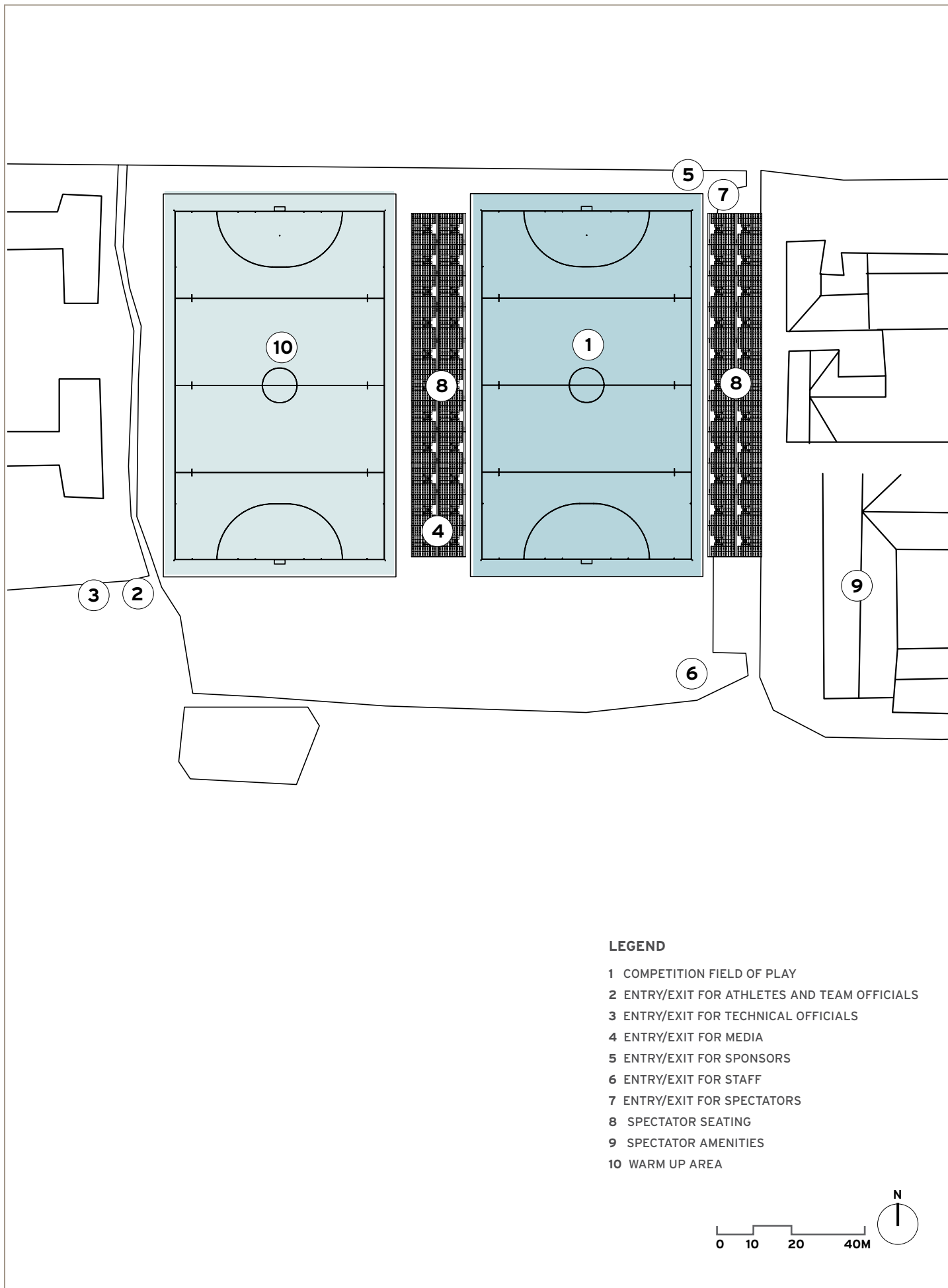

**LEGEND**

- 1 COMPETITION FIELD OF PLAY
- 2 ENTRY/EXIT FOR ATHLETES AND TEAM OFFICIALS
- 3 ENTRY/EXIT FOR TECHNICAL OFFICIALS
- 4 ENTRY/EXIT FOR MEDIA
- 5 ENTRY/EXIT FOR SPONSORS
- 6 ENTRY/EXIT FOR STAFF
- 7 ENTRY/EXIT FOR SPECTATORS
- 8 SPECTATOR SEATING
- 9 SPECTATOR AMENITIES
- 10 WARM UP AREA

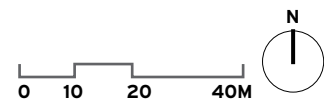



## SPORT: FOOTBALL

### VENUES:

**A | BMO FIELD**

**B | VARSITY STADIUM**

**C | RON JOYCE STADIUM**

**D | SHERWOOD PARK**

BMO Field is located at Exhibition Place in Toronto and is Canada's first football-specific stadium. BMO Field is home of Canada's National Football Team as well as the Toronto Football Club, Canada's first Major League Football team.

In the Summer of 2007, BMO Field was the main venue for the FIFA U-20 World Cup, in which it hosted over 260,000 people and twelve games. In its first year of operation, over 500,000 people entered BMO Field's gates.

### A | BMO FIELD

#### CURRENT STATUS

- Existing
- Built in 2007
- Current/Future Owner: City of Toronto

#### VENUE HIGHLIGHTS

- Meets all International Federation specifications
- Seating Capacity: 20,000
- Distance from village: 5 minutes/6km
- Parking spaces: over 7,400

#### CURRENT AND POST GAMES USE

- The venue is home to the Canadian National Team and the Toronto Football Club, a Major League Football franchise.
- Hosting Experience:
  - 2008 MLS All-Star Game
  - 2007 - Present: Toronto Football Club
  - 2007 FIFA U-20 World Cup



### > COMPETITION SCHEDULE

JULY																		
Day	Thu	Fri	Sat	Sun	Mon	Tues	Wed	Thu	Fri	Sat	Sun	Mon	Tue	Wed	Thu	Fri	Sat	Sun
Date	9	10	11	12	13	14	15	16	17	18	19	20	21	22	23	24	25	26
Football (W)	●		●		●		●		●			●			●	●		
Football (M)				●			●			●			●		●	●		

- Competition    ● Finals (may include competitions on these days)

> COMPETITION SITE PLANS

A | BMO FIELD

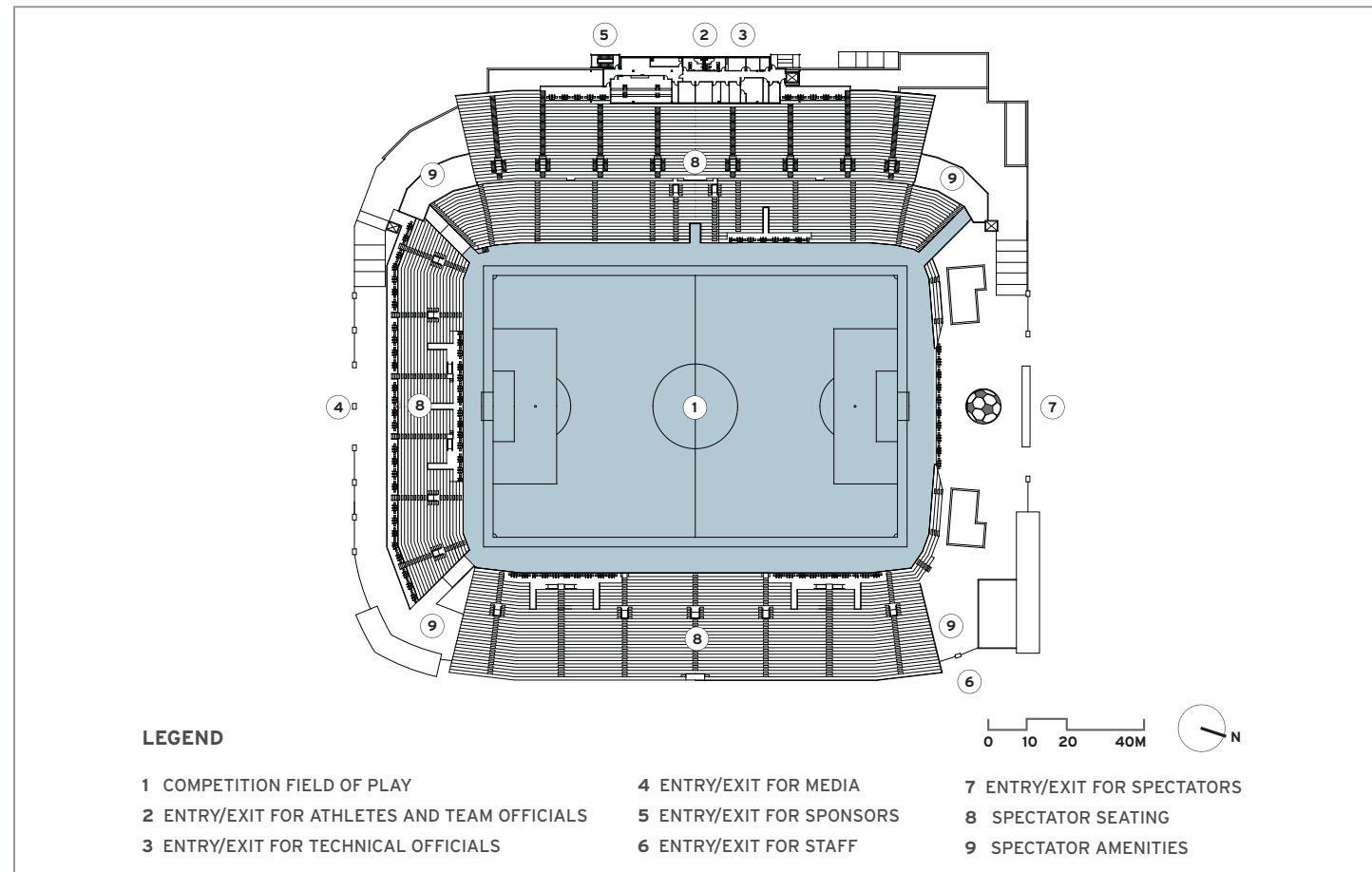

B | VARSITY STADIUM

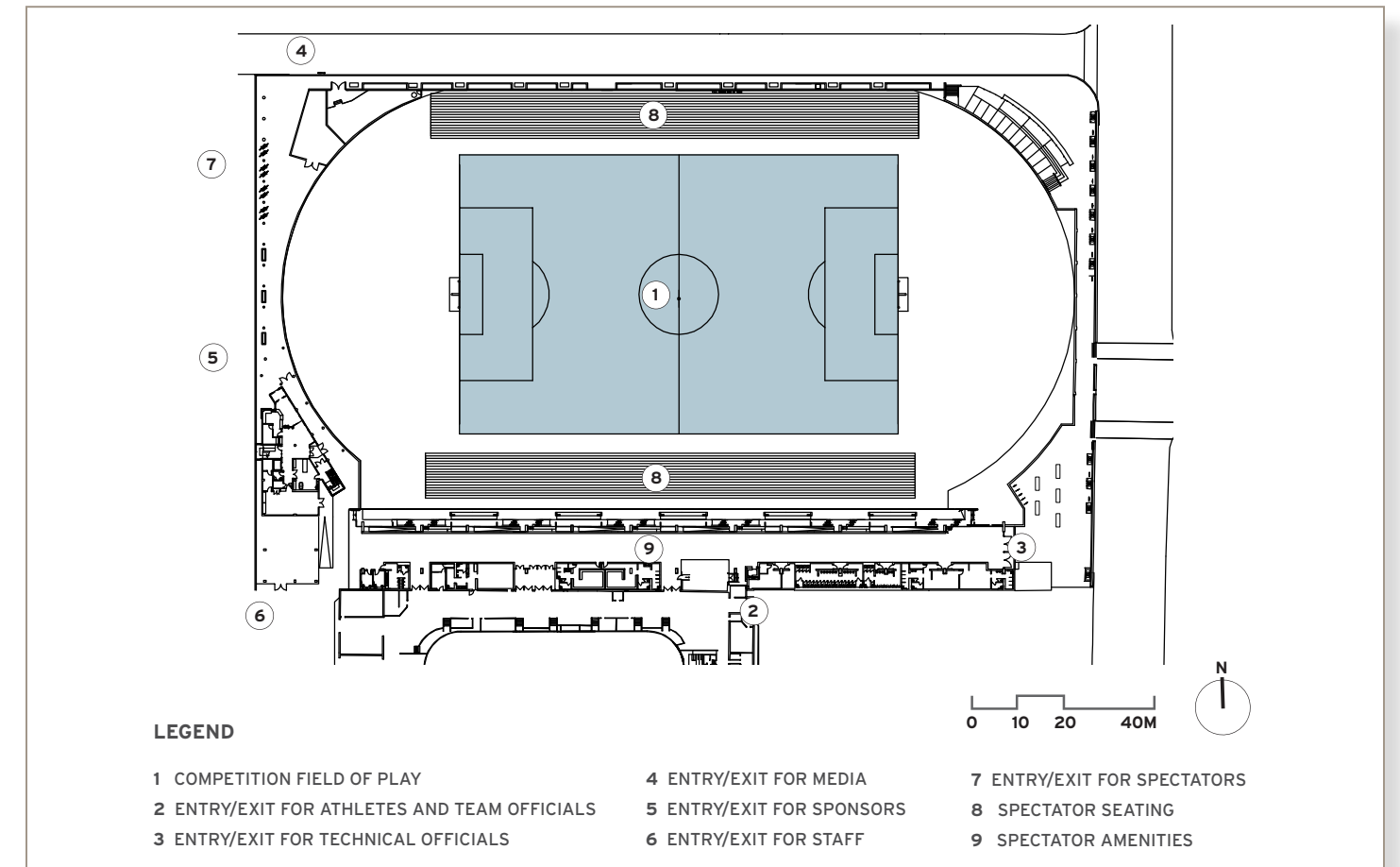

C | RON JOYCE STADIUM

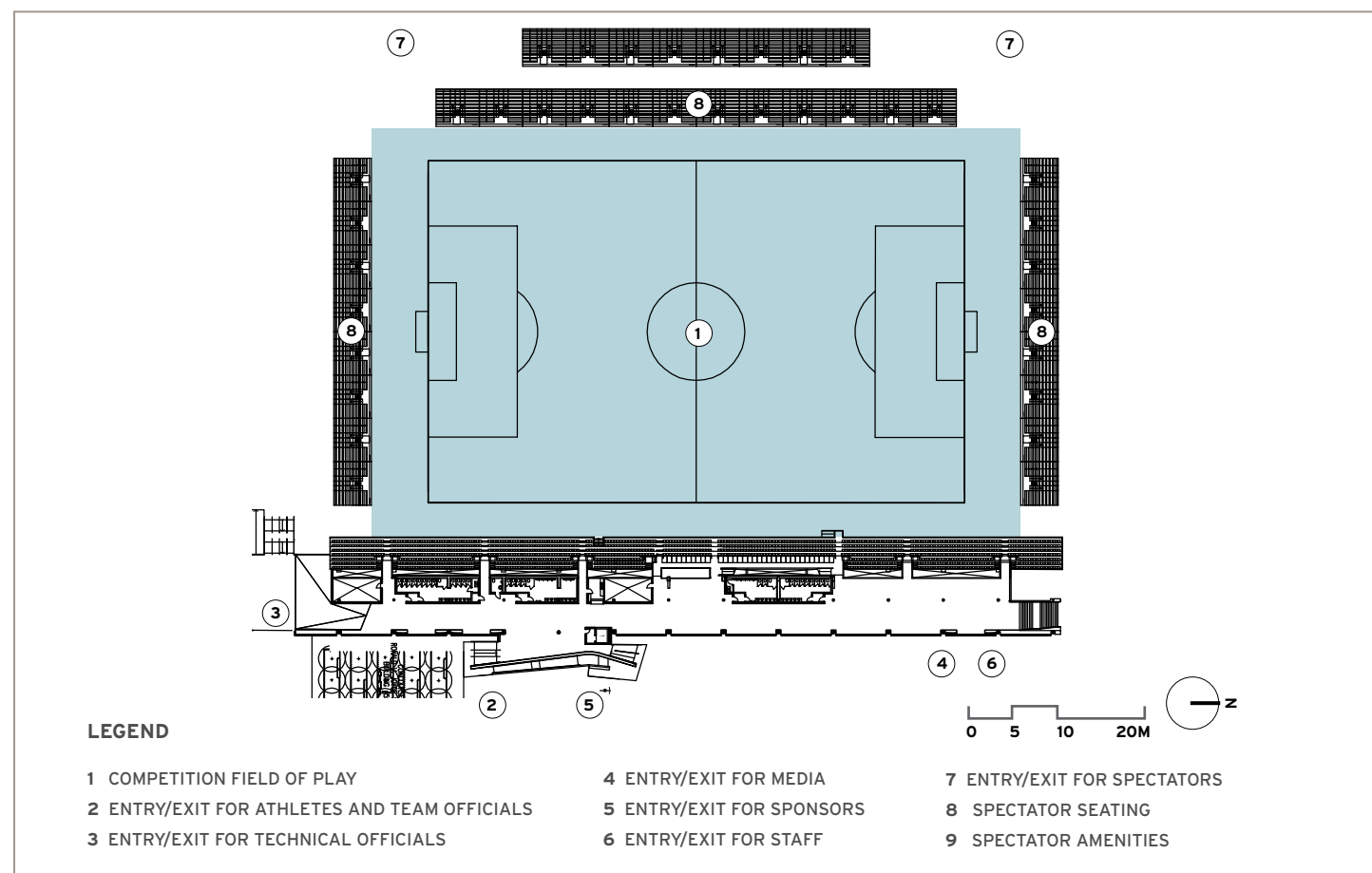

D | SHERWOOD PARK

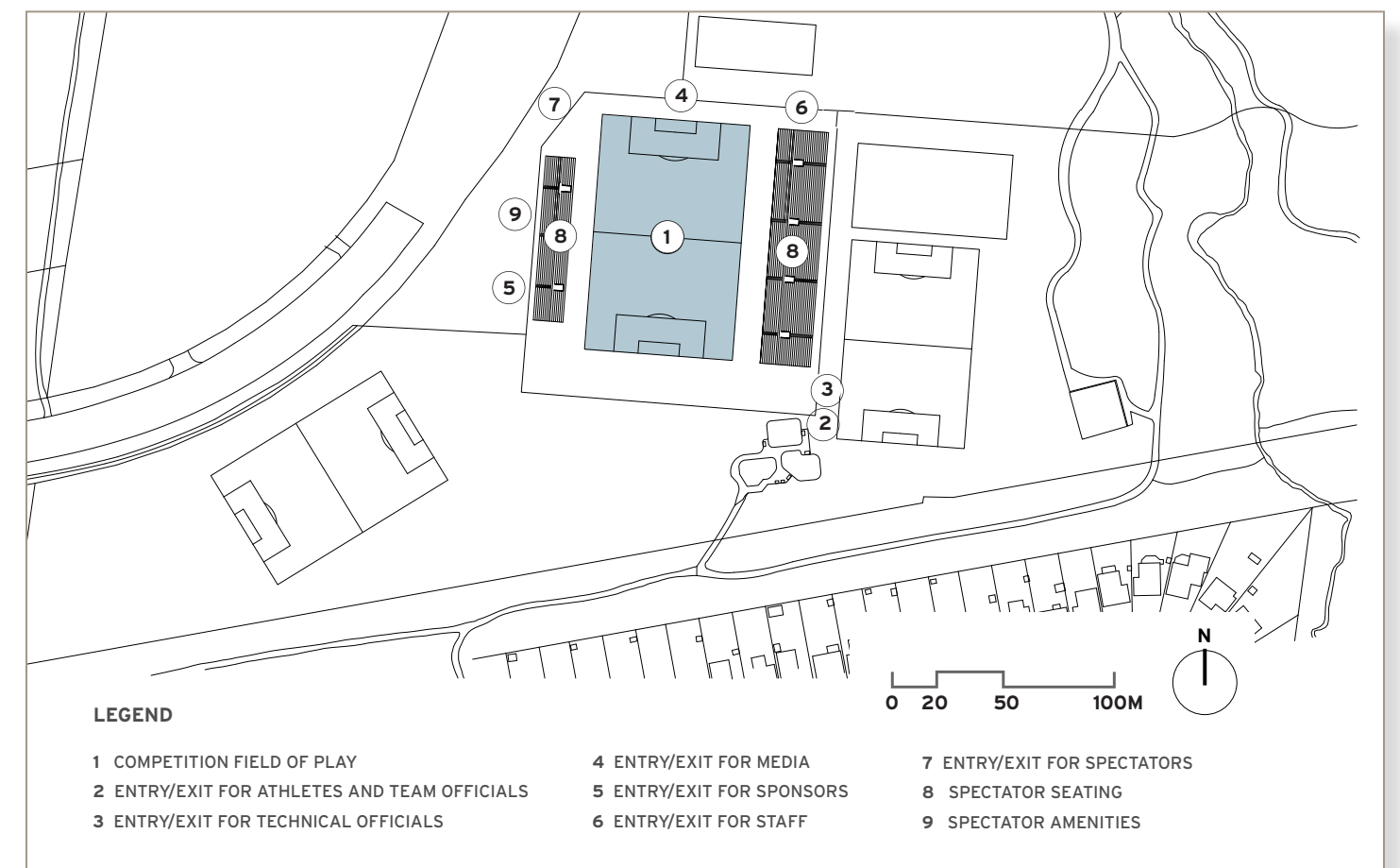

**B | VARSITY STADIUM**

Varsity Stadium is located on the campus of the University of Toronto, in the heart of Toronto, just minutes from the Pan American Village. It is also the site of the Opening and Closing Ceremonies for the 2015 Parapan American Games.

This facility, with 10,000 seats, is a key venue for Football and includes access to the best sport science practitioners and technology at the new Goldring Centre for High Performance Sport, which is also the site for Futsal.

CURRENT STATUS
<ul style="list-style-type: none"> <li>Existing, Minor Retrofit</li> <li>Built in 2006</li> <li>Current/Future owner: University of Toronto</li> </ul>
VENUE HIGHLIGHTS
<ul style="list-style-type: none"> <li>Meets all International Federation specifications</li> <li>Seating Capacity: 10,000</li> <li>Distance from village: 5 minutes / 6 km</li> <li>Parking spaces: over 3,000</li> </ul>
CURRENT AND POST GAMES USE
<ul style="list-style-type: none"> <li>This is the competition venue for the University of Toronto Varsity Blues (American) Football, Football and Athletics teams.</li> <li>Hosting Experience:               <ul style="list-style-type: none"> <li>2009 Festival of Champions, featuring Jamaica's world record holder Usain Bolt (June, 2009)</li> </ul> </li> </ul>

**C | RON JOYCE STADIUM**

Ron Joyce Stadium is a new state-of-the-art football (American style) facility at McMaster University, which will be converted to a football stadium for the 2015 Pan American Games.

This venue will provide all participants with a unique setting, in close proximity (less than five km) from the Athletics, Volleyball and Track Cycling venues.

CURRENT STATUS
<ul style="list-style-type: none"> <li>Existing, Minor Retrofit</li> <li>Built in 2008</li> <li>Current/Future owner: McMaster University</li> </ul>
VENUE HIGHLIGHTS
<ul style="list-style-type: none"> <li>Meets all International Federation specifications</li> <li>Seating Capacity: 10,000</li> <li>Distance from village: 50 minutes / 69 km</li> <li>Parking spaces: over 2,000</li> </ul>
CURRENT AND POST GAMES USE
<ul style="list-style-type: none"> <li>This is the competition venue for the McMaster University (American) Football and Football Teams, the Hamilton Tiger-Cats of the Canadian Football League also use the stadium for training during the spring and summer.</li> </ul>

**D | SHERWOOD PARK**

The Pan American Games will be the catapult for the development of a new outdoor complex for football and other field sports.

At 10,000 seats, this new development will provide a high level competition field where participants and spectators will enjoy the 'beautiful game', as well as training grounds for participating teams.

CURRENT STATUS
<ul style="list-style-type: none"> <li>New Build</li> <li>Construction status: Completed by 2014</li> <li>Current/Future owner: City of Burlington</li> </ul>
VENUE HIGHLIGHTS
<ul style="list-style-type: none"> <li>Meets all International Federation specifications</li> <li>Seating Capacity: 10,000</li> <li>Distance from village: 40 minutes / 52 km</li> <li>Parking spaces: over 2,500</li> </ul>
CURRENT AND POST GAMES USE
<ul style="list-style-type: none"> <li>This venue will become a field sport legacy project that will provide a significant venue that will be utilized by high performance sport athletes, sport development programs and community groups.</li> </ul>

**SPORT:  
GYMNASTICS****VENUE: Direct Energy Centre - Ricoh Coliseum**

With stunning design, the Direct Energy Centre is the focal point of Toronto's Exhibition Place, a lakefront complex that's a vibrant destination for public celebrations, festivals and events.

The three disciplines of Gymnastics, Artistic, Rhythmic and Trampoline will be hosted at the Ricoh Coliseum at Exhibition Place, the location of a significant cluster of sports for the Games, minutes from the Pan American Village.

Ricoh Coliseum is part of the Direct Energy Centre, and Hall A of the Centre will host the training and warm-up components of gymnastics. The trampoline warm up site will be metres away from the competition site.

Sports competing at Exhibition Place also include Karate, Road Cycling, Beach Volleyball, Triathlon, Football, and Handball.

**> SPORT & VENUE SPECIFICATIONS**

CURRENT STATUS
<ul style="list-style-type: none"> <li>Existing</li> <li>Renovated in 2003</li> <li>Current/Future owner: City of Toronto</li> </ul>
VENUE HIGHLIGHTS
<ul style="list-style-type: none"> <li>Meets all International Federation specifications</li> <li>Training/warm-up area adjacent to venue</li> <li>Seating Capacity: 8,500</li> <li>Distance from village: 5 minutes / 5 km</li> <li>Parking spaces: 7,400</li> </ul>
CURRENT AND POST GAMES USE
<ul style="list-style-type: none"> <li>Multipurpose venue with facilities to host exhibition, conference and sport events.</li> <li>Hosting Experience:               <ul style="list-style-type: none"> <li>2007 American Hockey League All-Star Game</li> <li>2005 - Present: AHL Toronto Marlies</li> <li>FEI World Cup Grand Prix Events (Equestrian)</li> </ul> </li> </ul>

**> COMPETITION SCHEDULE**

		JULY																	
Day		Thu	Fri	Sat	Sun	Mon	Tues	Wed	Thu	Fri	Sat	Sun	Mon	Tue	Wed	Thu	Fri	Sat	Sun
Date		9	10	11	12	13	14	15	16	17	18	19	20	21	22	23	24	25	26
Artistic				●	●	●	●												
Rhythmic Gymnastics															●	●	●		
Trampoline																●	●		

● Competition ● Finals (may include competitions on these days)

> COMPETITION SITE PLAN

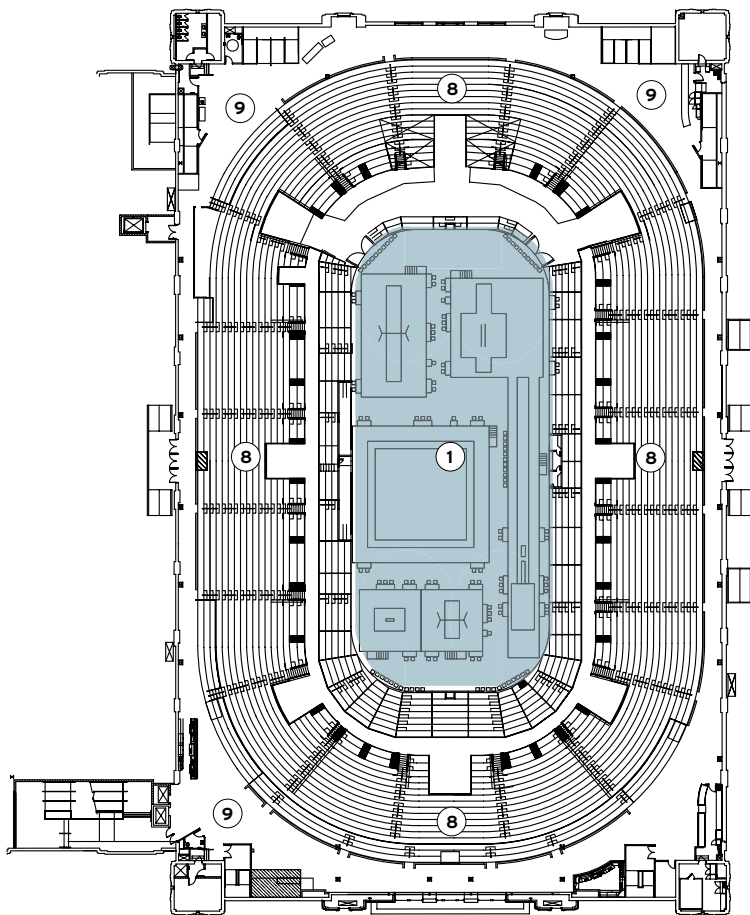
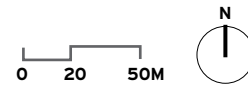
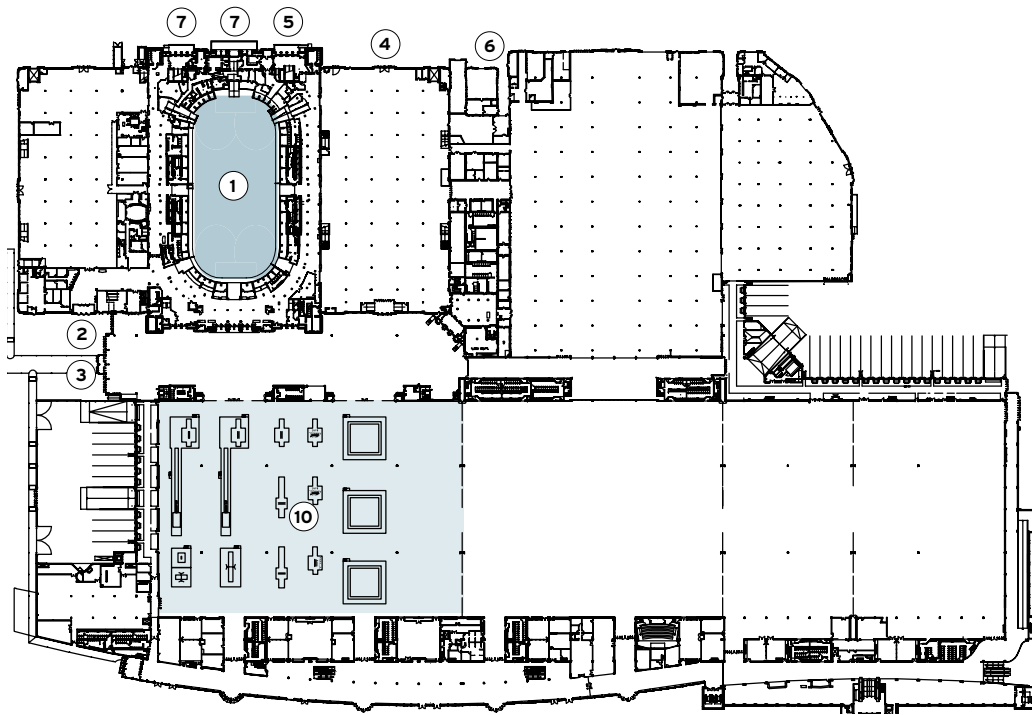

**LEGEND**

- 1 COMPETITION FIELD OF PLAY
- 2 ENTRY/EXIT FOR ATHLETES AND TEAM OFFICIALS
- 3 ENTRY/EXIT FOR TECHNICAL OFFICIALS
- 4 ENTRY/EXIT FOR MEDIA
- 5 ENTRY/EXIT FOR SPONSORS
- 6 ENTRY/EXIT FOR STAFF
- 7 ENTRY/EXIT FOR SPECTATORS
- 8 SPECTATOR SEATING
- 9 SPECTATOR AMENITIES
- 10 WARM UP - TRAINING AREA

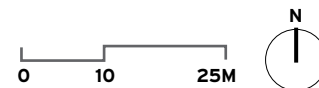



## SPORT: HANDBALL

### VENUE: Direct Energy Centre

With stunning design, the Direct Energy Centre is the focal point of Toronto's Exhibition Place, a lakefront complex that is a vibrant destination for public celebrations, festivals and events.

Magnificent in size and flexibility, the venue offers 100,000 m<sup>2</sup> of contiguous exhibit and event space, divisible into nine halls. Adapted for a number of sports, the Handball competition will be housed in this facility, which includes a significant cluster of sports for the Games, minutes from the Pan American Village.

Sports competing at Exhibition Place also include Karate, Gymnastics, Beach Volleyball, Triathlon, Football, and Road Cycling.



### > SPORT & VENUE SPECIFICATIONS

#### CURRENT STATUS

- Existing
- Built in 1997
- Current/Future owner: City of Toronto

#### VENUE HIGHLIGHTS

- Meets all International Federation specifications
- Seating Capacity: 1,000
- Distance from village: 5 minutes/6 km
- Parking spaces: 7,400

#### CURRENT AND POST GAMES USE

- Exhibition Place is a mixed-use property on the Toronto shore of Lake Ontario, featuring expo, trade, and banquet centres, theater and music buildings, parkland, sports facilities, and a number of civic, provincial, and national historic sites.
- Hosting Experience:
  - 2003 Dalai Lama's Visit
  - 2002 Royal Visit / Queen Elizabeth II
  - 2002 World Youth Day / Pope John Paul II



### > COMPETITION SCHEDULE

JULY																		
Day	Thu	Fri	Sat	Sun	Mon	Tues	Wed	Thu	Fri	Sat	Sun	Mon	Tue	Wed	Thu	Fri	Sat	Sun
Date	9	10	11	12	13	14	15	16	17	18	19	20	21	22	23	24	25	26
Handball - Team (W)									●		●		●		●		●	
Handball - Team (M)										●		●		●		●		●

- Competition
- Finals (may include competitions on these days)

> COMPETITION SITE PLAN

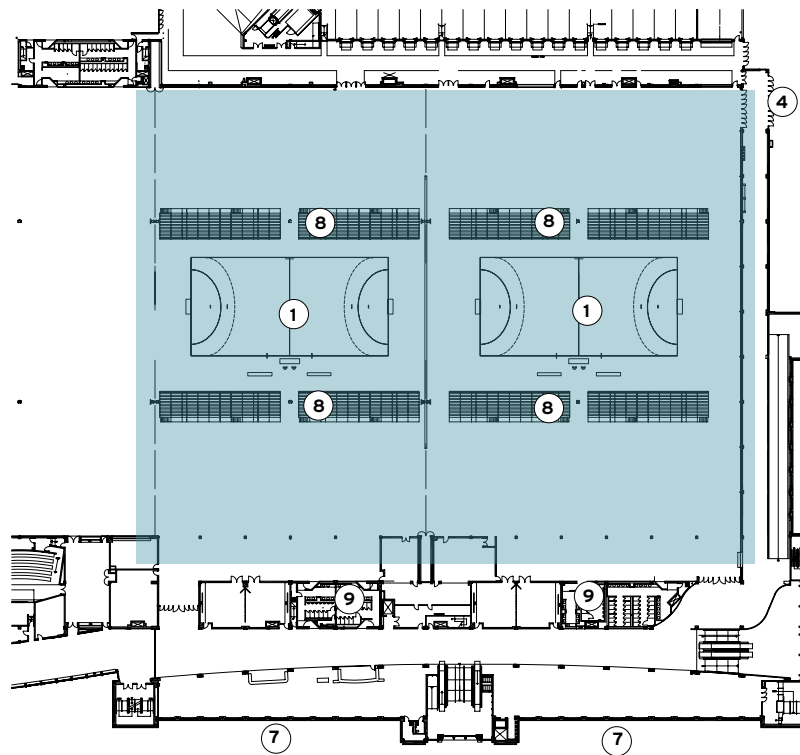
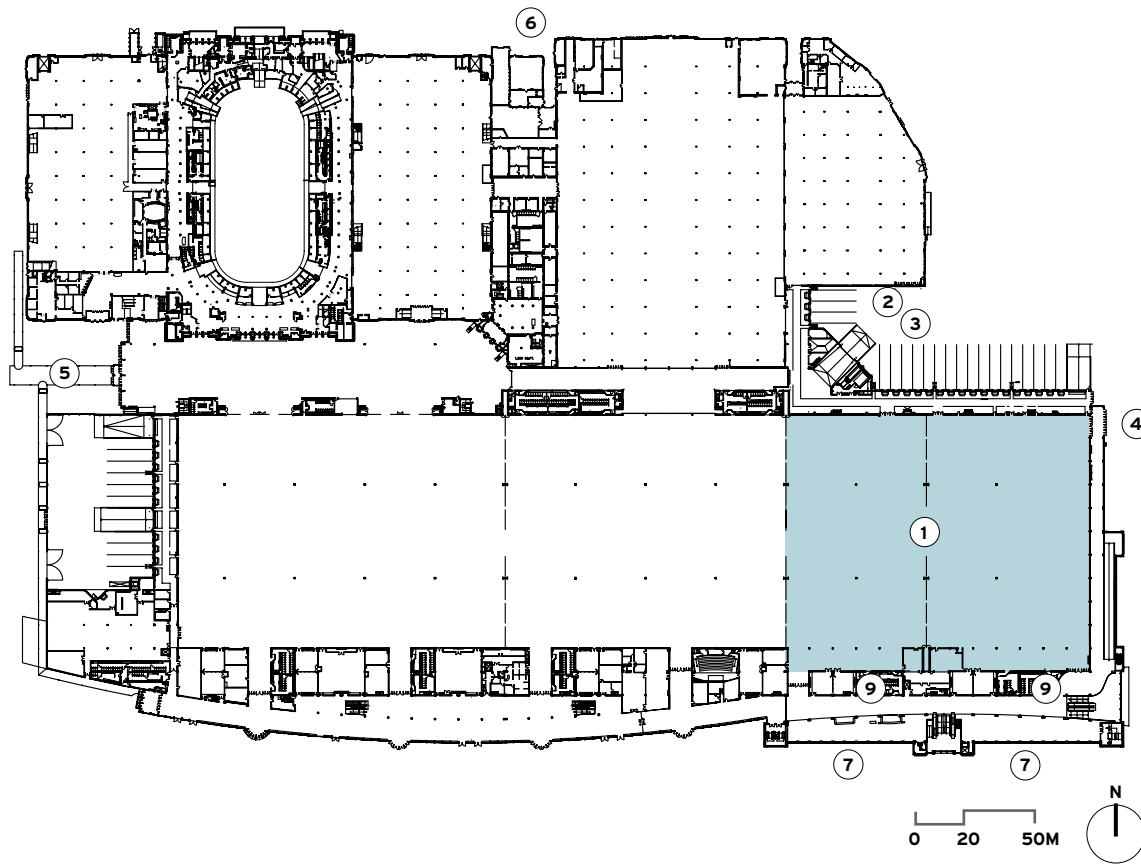

**LEGEND**

- |  |                             |
|--|-----------------------------|
| 1 COMPETITION FIELD OF PLAY                  | 7 ENTRY/EXIT FOR SPECTATORS |
| 2 ENTRY/EXIT FOR ATHLETES AND TEAM OFFICIALS | 8 SPECTATOR SEATING         |
| 3 ENTRY/EXIT FOR TECHNICAL OFFICIALS         | 9 SPECTATOR AMENITIES       |
| 4 ENTRY/EXIT FOR MEDIA                       |                             |
| 5 ENTRY/EXIT FOR SPONSORS                    |                             |
| 6 ENTRY/EXIT FOR STAFF                       |                             |

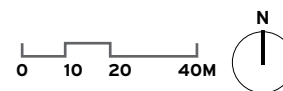



## SPORT: JUDO

### VENUE: Hershey Centre

The Hershey Centre is a multi-sport facility which showcases local, national and international talent in excellent facilities including arenas, spectator facilities, gymnasia and a FIFA regulation indoor turf field.

As a combative sports hub, the facility will include the competitions of Judo and Taekwondo with room for 5,400 spectators ready to appreciate the grace, agility and strength of these competitors.



### > SPORT & VENUE SPECIFICATIONS

#### CURRENT STATUS

- Existing
- Built in 1998
- Current/Future Owner: City of Mississauga

#### VENUE HIGHLIGHTS

- Meets all International Federation specifications
- Seating Capacity: 5,400
- Distance from village: 27 minutes/32 km
- Parking spaces: 1,920

#### CURRENT AND POST GAMES USE

- This multi-sport facility will continue to serve the needs of community users and high performance athletes.
- Hosting Experience:
  - 2009 Harlem Globetrotters
  - 2008 World Junior Championship of Hockey
  - 2007 - Present: Ontario Hockey League (OHL) Mississauga St Michael's Majors
  - 1998-2007: OHL Mississauga Ice Dogs



### > COMPETITION SCHEDULE

JULY																		
Day	Thu	Fri	Sat	Sun	Mon	Tues	Wed	Thu	Fri	Sat	Sun	Mon	Tue	Wed	Thu	Fri	Sat	Sun
Date	9	10	11	12	13	14	15	16	17	18	19	20	21	22	23	24	25	26
Judo												•	•	•	•			

- Finals (may include competitions on these days)

> COMPETITION SITE PLAN

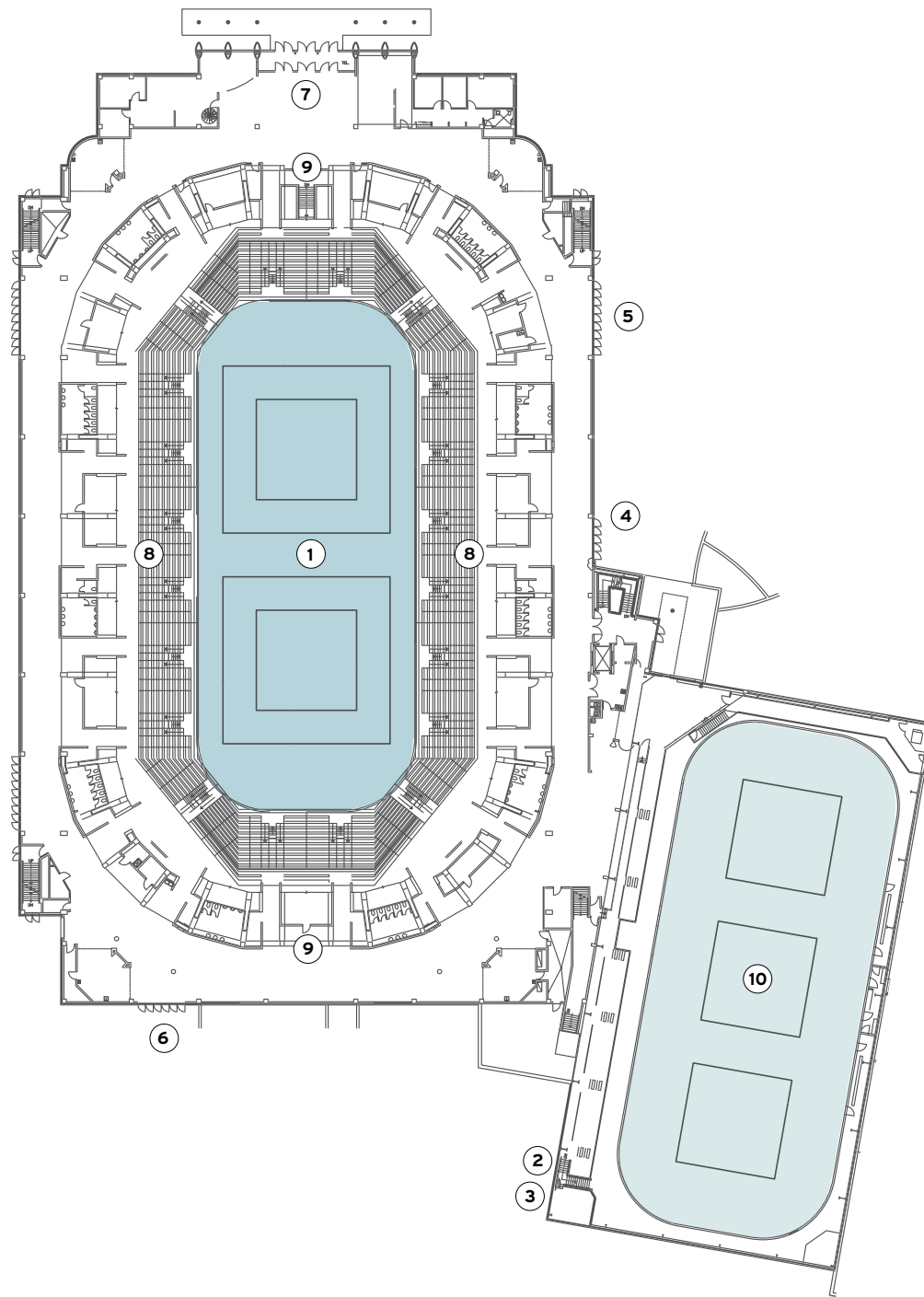

**LEGEND**

- |  |                             |
|--|-----------------------------|
| 1 COMPETITION FIELD OF PLAY                  | 7 ENTRY/EXIT FOR SPECTATORS |
| 2 ENTRY/EXIT FOR ATHLETES AND TEAM OFFICIALS | 8 SPECTATOR SEATING         |
| 3 ENTRY/EXIT FOR TECHNICAL OFFICIALS         | 9 SPECTATOR AMENITIES       |
| 4 ENTRY/EXIT FOR MEDIA                       | 10 WARM UP AREA             |
| 5 ENTRY/EXIT FOR SPONSORS                    |                             |
| 6 ENTRY/EXIT FOR STAFF                       |                             |

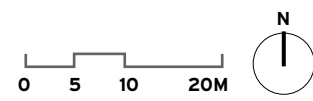



## SPORT: MODERN PENTATHLON

### VENUE: Canadian Sport Institute Ontario & Pan American Aquatics Centre

The fencing and swimming components of the Modern Pentathlon will be held at the Canadian Sport Institute Ontario and the Pan American Aquatics Centre with 10,000 seats, two 10 lane, 50m pools and a significant 3,000 seat field house, all including the latest technology to support high performance summer sports.

Located on the grounds of the University of Toronto and the City of Toronto, the Pan American Aquatics Centre is a collaborative project between the University, the City of Toronto and the 2015 Pan American Games, which combines the needs of a major event, Canada's largest university, and Canada's largest city.

#### > SPORT & VENUE SPECIFICATIONS

##### CURRENT STATUS

- New build
- Construction Status: Completed by 2014
- Current/Future owner:  
University of Toronto/City of Toronto

##### VENUE HIGHLIGHTS

- Meets all International Federation specifications
- Seating Capacity (Swimming): 10,000
- Seating Capacity (Fencing): 3,000
- Distance from village: 22 minutes/29 km
- Parking spaces: over 3,000

##### CURRENT AND POST GAMES USE

- The facility will link together community sport and recreation use, competitive use by university and sports clubs, a national training centre for Canada's top athletes and provide a venue to host the world for major national and international competitions.



#### > COMPETITION SCHEDULE | MODERN PENTATHLON

JULY																		
Day	Thu	Fri	Sat	Sun	Mon	Tues	Wed	Thu	Fri	Sat	Sun	Mon	Tue	Wed	Thu	Fri	Sat	Sun
Date	9	10	11	12	13	14	15	16	17	18	19	20	21	22	23	24	25	26
Modern Pentathlon										●	●							

- Competition
- Finals (may include competitions on these days)

> COMPETITION SITE PLANS

CANADIAN SPORT INSTITUTE ONTARIO & PAN AMERICAN AQUATICS CENTRE - FENCING/SWIMMING

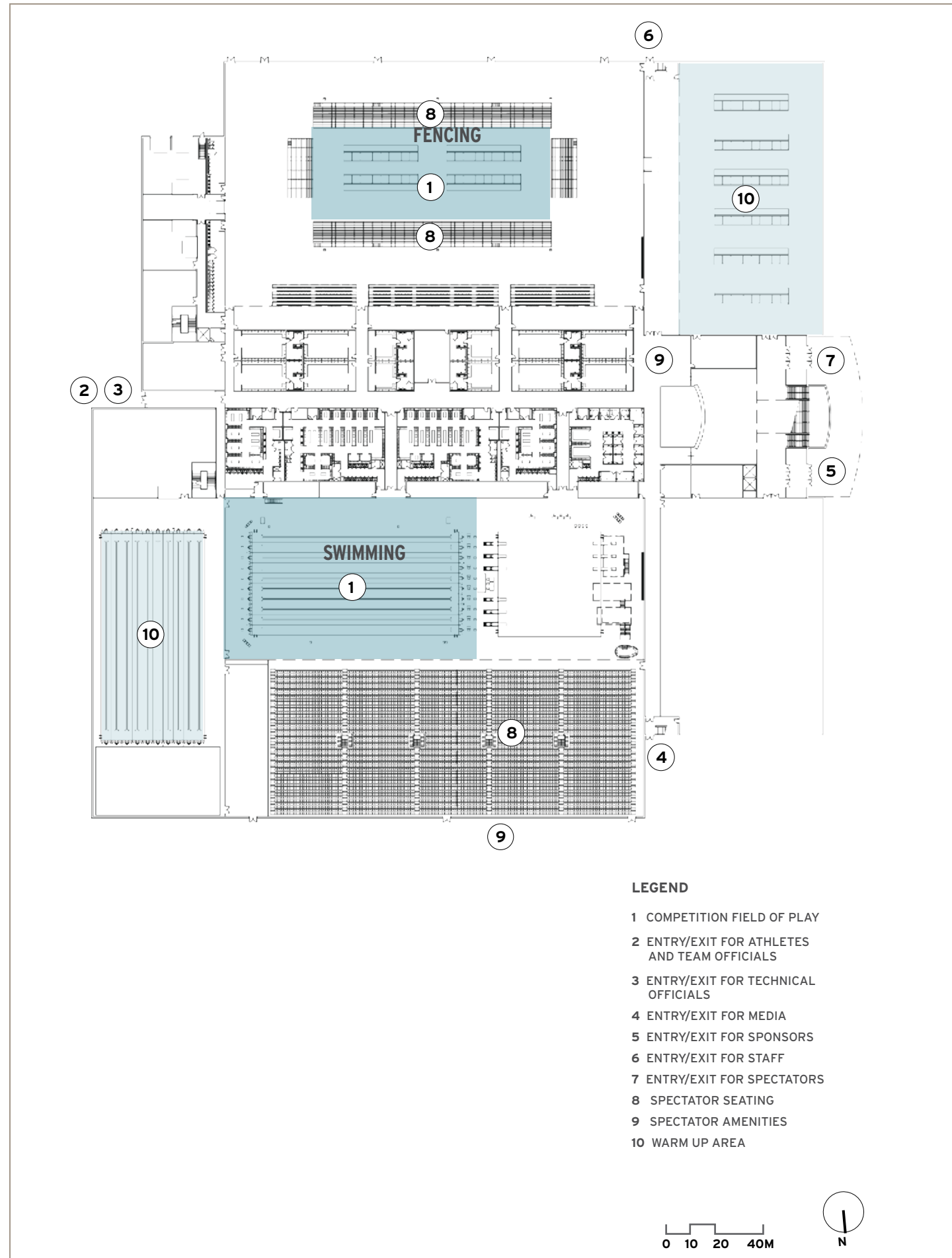

PICKERING HORSE CENTRE - RUNNING/EQUESTRIAN/SHOOTING

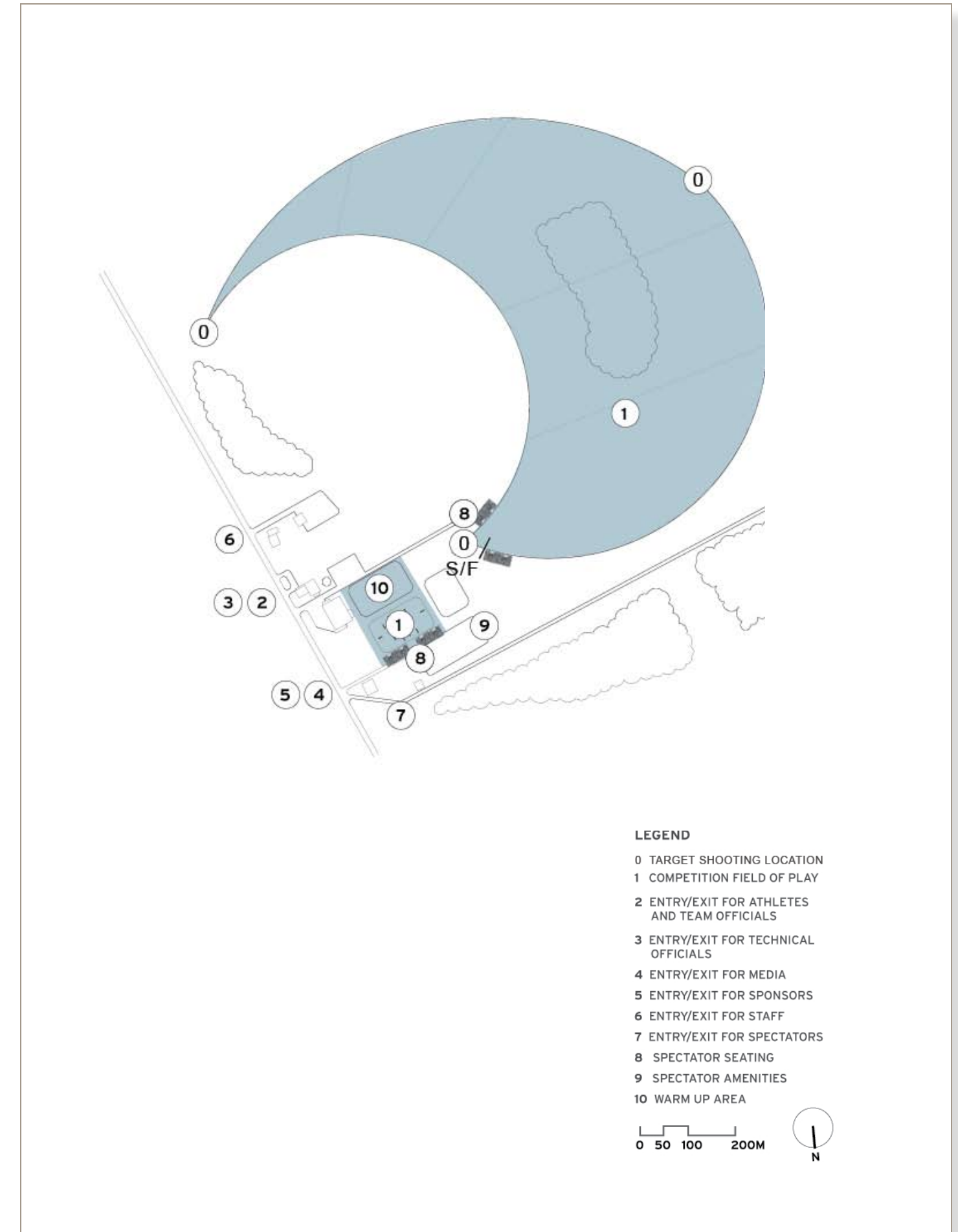



## SPORT: MODERN PENTATHLON

### VENUE: Pickering Horse Centre

The equestrian, running and shooting components will be a short distance away at the Pickering Horse Centre, where participants and spectators will be transported to an equine facility which will include all the amenities required for a first class competition.



#### > SPORT & VENUE SPECIFICATIONS

CURRENT STATUS
<ul style="list-style-type: none"> <li>Existing</li> <li>Built in 1988</li> <li>Current/Future owners: Pickering Horse Centre</li> </ul>
VENUE HIGHLIGHTS
<ul style="list-style-type: none"> <li>Meets all International Federation specifications</li> <li>Seating Capacity: 1,500</li> <li>Distance from village: 37 minutes / 52 km</li> <li>Parking spaces: over 500</li> </ul>
CURRENT AND POST GAMES USE
<ul style="list-style-type: none"> <li>Pickering Horse Centre supports the enjoyment of equestrian enthusiasts, as well as the development of recreational and sport participants, through lessons, summer camp opportunities and hosting events.</li> </ul>



## SPORT: ROWING

### VENUE: Royal Canadian Henley Rowing Course

Nestled in the heart of the Niagara wine country, the Royal Canadian Henley Rowing Course is a spectacular venue for both domestic and international events.

This FISA Category "A" International Rowing Course, has significant experience in hosting major rowing events, including the Royal Canadian Henley Regatta, a six-day, world class rowing competition drawing over 3,000 competitors from around the world.

This venue will provide athletes an opportunity to compete on a proven world class course, which provides impressive sightlines and calm waters required to reach the highest level of sport excellence possible.

To ensure the athletes can perform at optimum levels, and based on the advice of the International Sport Federation (Rowing) we will make available athlete and team official accommodations within 20 minutes of the competitive venue.

#### > SPORT & VENUE SPECIFICATIONS

CURRENT STATUS
<ul style="list-style-type: none"> <li>Existing/Minor Retrofit</li> <li>Construction status: Completed by 2014</li> <li>Current/Future owner: City of St. Catharines</li> </ul>
VENUE HIGHLIGHTS
<ul style="list-style-type: none"> <li>Meets all International Federation specifications</li> <li>Seating Capacity: 2,500</li> <li>Distance from village: 80 minutes / 110 km</li> <li>Parking spaces: 500</li> </ul>
CURRENT AND POST GAMES USE
<ul style="list-style-type: none"> <li>The rowing facilities are used year round by the rowing clubs who operate several programs including learn to row and recreational rowing, as well as a training centre for the national team.</li> <li>There are a number of large regatta events hosted on the course throughout the year, including the Royal Canadian Henley Regatta.</li> <li>Hosting Experience: <ul style="list-style-type: none"> <li>1903 - Present: Annual Royal Canadian Henley Regatta</li> <li>1999 FISA World Rowing Championships</li> </ul> </li> </ul>



#### > COMPETITION SCHEDULE

JULY																		
Day	Thu	Fri	Sat	Sun	Mon	Tues	Wed	Thu	Fri	Sat	Sun	Mon	Tue	Wed	Thu	Fri	Sat	Sun
Date	9	10	11	12	13	14	15	16	17	18	19	20	21	22	23	24	25	26
Rowing			●	●	●	●	●	●										

● Competition ● Finals (may include competitions on these days)



> COMPETITION SITE PLAN

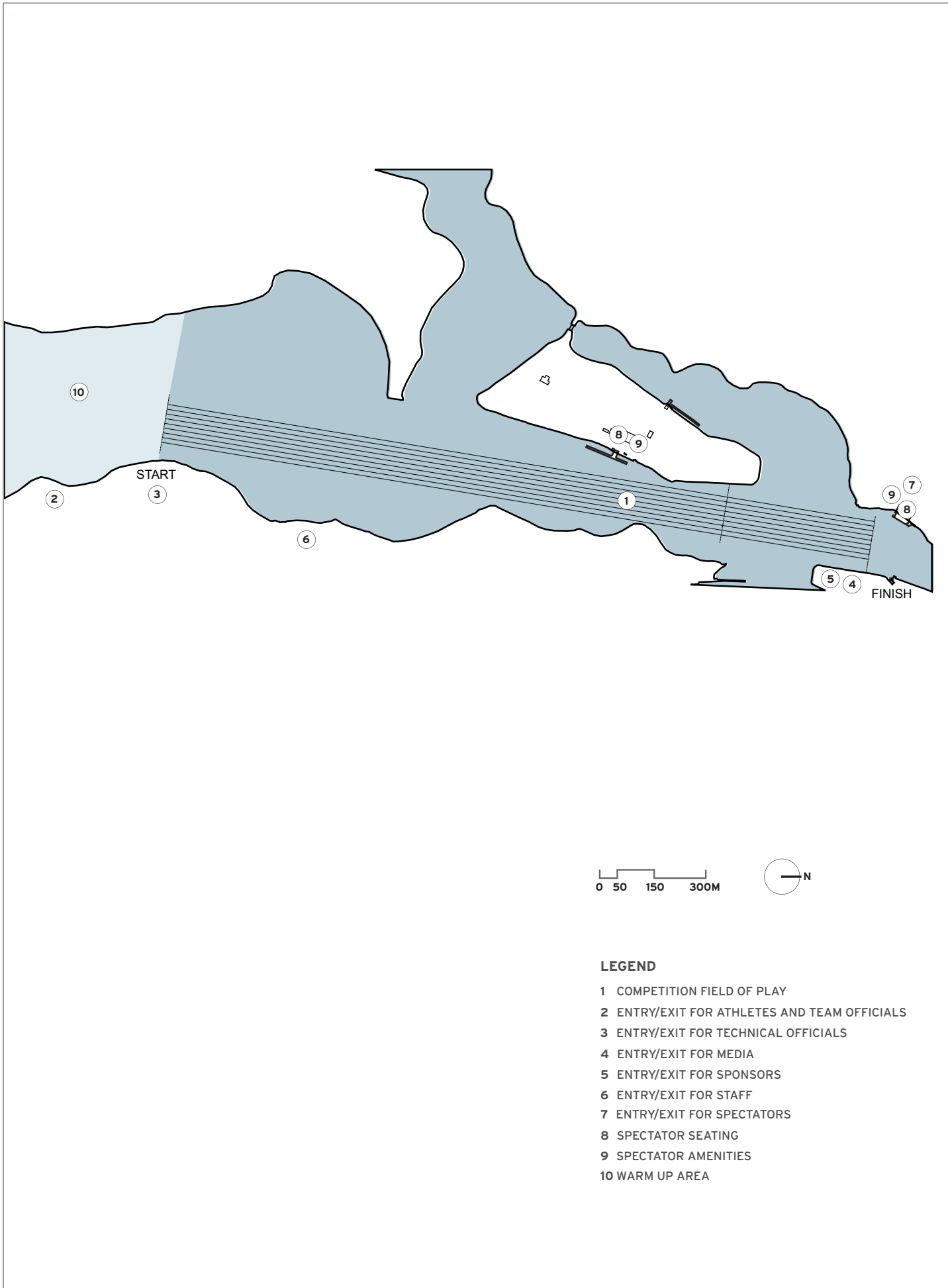

**LEGEND**

- 1 COMPETITION FIELD OF PLAY
- 2 ENTRY/EXIT FOR ATHLETES AND TEAM OFFICIALS
- 3 ENTRY/EXIT FOR TECHNICAL OFFICIALS
- 4 ENTRY/EXIT FOR MEDIA
- 5 ENTRY/EXIT FOR SPONSORS
- 6 ENTRY/EXIT FOR STAFF
- 7 ENTRY/EXIT FOR SPECTATORS
- 8 SPECTATOR SEATING
- 9 SPECTATOR AMENITIES
- 10 WARM UP AREA





## SPORT: SAILING

### VENUE: Royal Canadian Yacht Club

Founded in 1852, the Royal Canadian Yacht Club (RCYC) is Canada's premier Sailing facility, with an emphasis on family participation, the development of junior sailors, and sport excellence in Sailing.

The Club is based on the Toronto islands with convenient ferry service from the club's dedicated parking and ferry facility adjacent to the Pan American Village. The RCYC is well positioned to provide all the amenities required for a world class competition and provide athletes and officials with a state of the art facility in an ideal setting for the games. The facility will provide easy access to the race course, the comforts of new installations and the best views of Toronto.



### > SPORT & VENUE SPECIFICATIONS

#### CURRENT STATUS

- Existing
- Built in 1881
- Current/Future owner: Royal Canadian Yacht Club

#### VENUE HIGHLIGHTS

- Meets all International Federation specifications
- Seating Capacity: over 500
- Distance from village: 15 minutes/1.3 km
- Parking spaces: over 200

#### CURRENT AND POST GAMES USE

- The RCYC is an important sailing facility providing world-class facilities for national and international training and hosting.
- Hosting Experience:
  - 2006 Shark World Championship
  - 2005 8 Metre World Championship
  - 2005 J/105 North American Championship
  - 2004 Bell Mumm 30 World Championship



### > COMPETITION SCHEDULE

JULY																		
Day	Thu	Fri	Sat	Sun	Mon	Tues	Wed	Thu	Fri	Sat	Sun	Mon	Tue	Wed	Thu	Fri	Sat	Sun
Date	9	10	11	12	13	14	15	16	17	18	19	20	21	22	23	24	25	26
Sailing					●	●	●	●	●	●	●							

- Competition
- Finals (may include competitions on these days)

> COMPETITION SITE PLAN

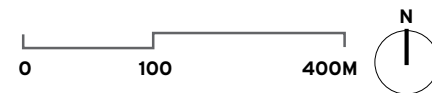
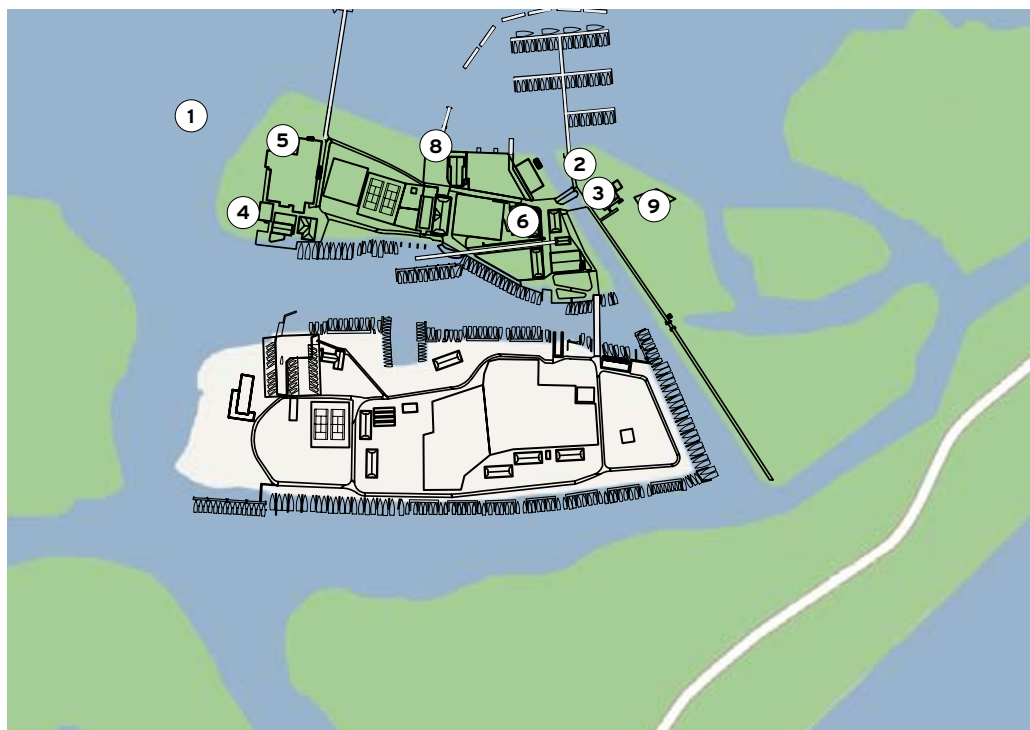
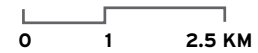

**LEGEND**

- |  |                             |
|--|-----------------------------|
| 1 COMPETITION FIELD OF PLAY                  | 7 ENTRY/EXIT FOR SPECTATORS |
| 2 ENTRY/EXIT FOR ATHLETES AND TEAM OFFICIALS | 8 SPECTATOR SEATING         |
| 3 ENTRY/EXIT FOR TECHNICAL OFFICIALS         | 9 SPECTATOR AMENITIES       |
| 4 ENTRY/EXIT FOR MEDIA                       | A B C D E YACHTING COURSE   |
| 5 ENTRY/EXIT FOR SPONSORS                    |                             |
| 6 ENTRY/EXIT FOR STAFF                       |                             |



**SPORT:**  
**SHOOTING**  
**INDOOR**

**VENUE: Ajax Community Centre**

The Ajax Community Centre is an important community sport and recreation facility that provides residents and athletes with a wide variety of facilities including four arenas, a 25m pool, squash courts, and a fitness centre.

Adapted to host the indoor shooting competition, this venue is a large complex that will provide all the amenities required for an international event.



**> SPORT & VENUE SPECIFICATIONS**

**CURRENT STATUS**

- Existing
- Built in 1967
- Current/Future Owner: Town of Ajax

**VENUE HIGHLIGHTS**

- Meets all International Federation specifications
- Seating Capacity: 1,500
- Distance from village: 38 minutes/45 km
- Parking spaces: over 500

**CURRENT AND POST GAMES USE**

- The facility is an important community asset providing community sport and recreation opportunities to residents.



**> COMPETITION SCHEDULE**

JULY																		
Day	Thu	Fri	Sat	Sun	Mon	Tues	Wed	Thu	Fri	Sat	Sun	Mon	Tue	Wed	Thu	Fri	Sat	Sun
Date	9	10	11	12	13	14	15	16	17	18	19	20	21	22	23	24	25	26
VENUE: OSHAWA GUN CLUB																		
Shooting - Indoor			●	●	●	●	●	●										
VENUE: SPORTSPLEX PARK COMMUNITY CENTRE																		
Shooting - Outdoor			●	●	●	●	●	●	●									

● Competition    ● Finals (may include competitions on these days)

> COMPETITION SITE PLANS

AJAX COMMUNITY CENTRE - SHOOTING INDOOR

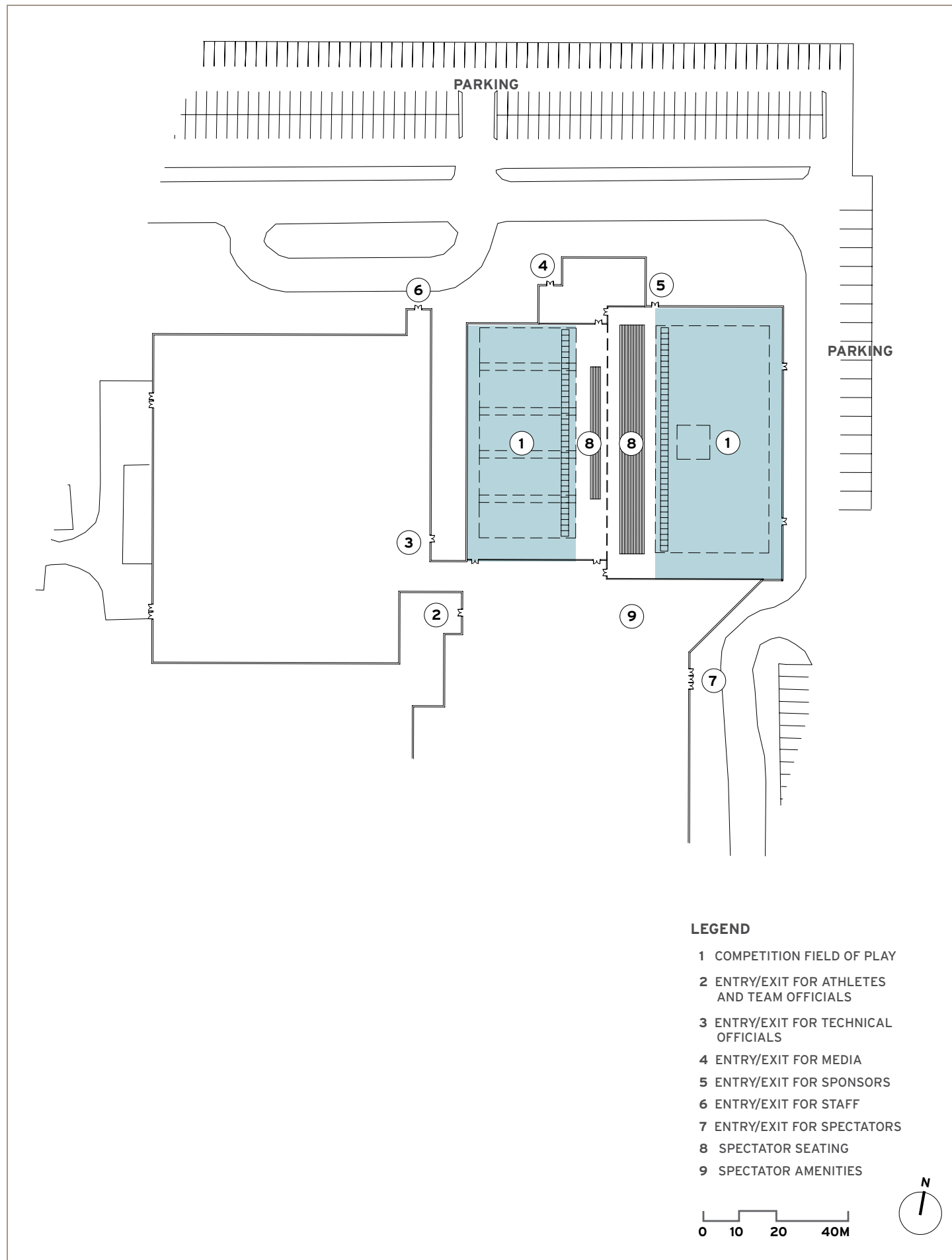

OSHAWA SKEET & GUN CLUB - SHOOTING OUTDOOR

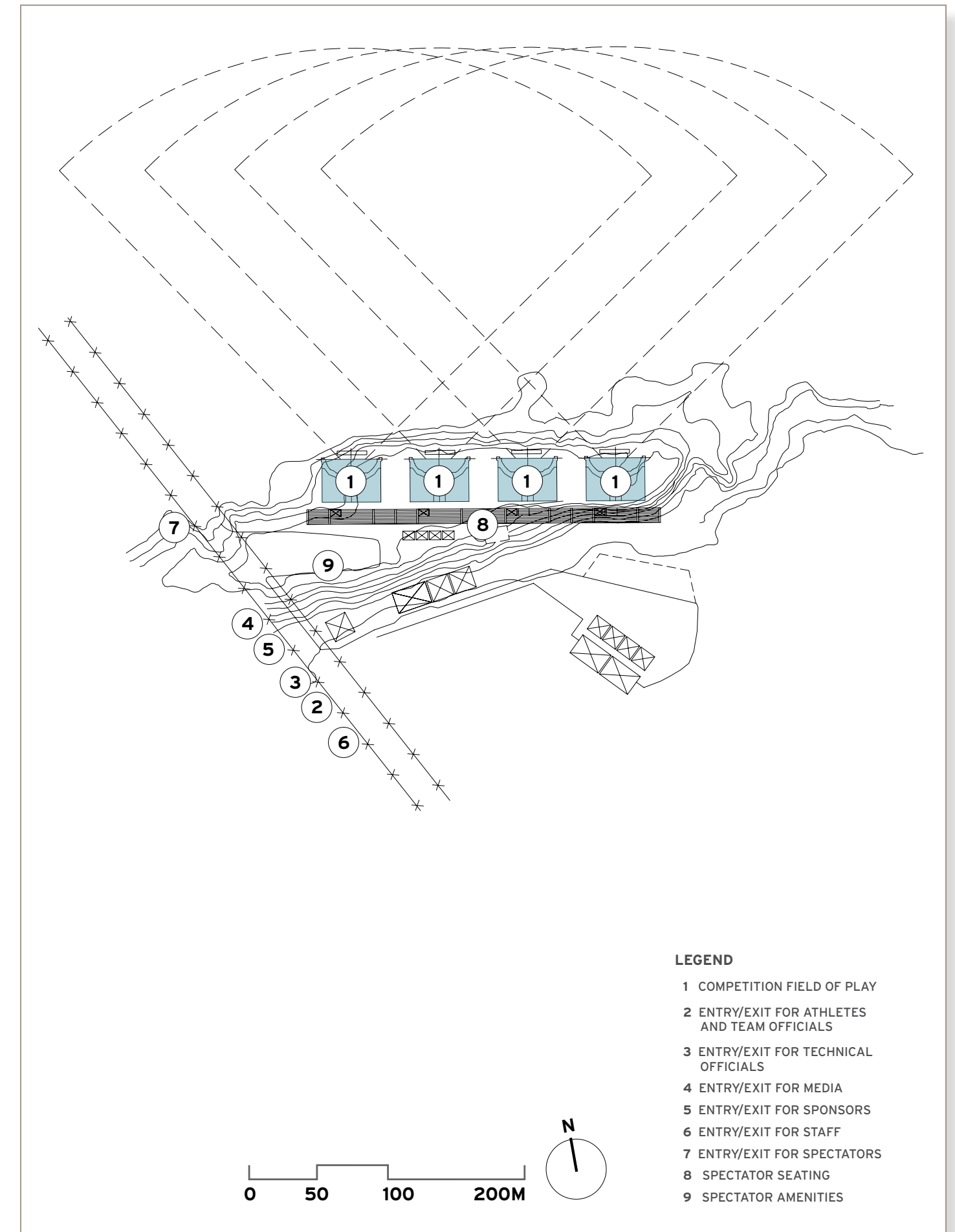



**SPORT:**  
**SHOOTING**  
**OUTDOOR**

**VENUE: Oshawa Skeet & Gun Club**

Located on a 100 acre property, the Oshawa Skeet & Gun Club is a large venue for competitive and recreational shooting.

Having hosted numerous national competitions, the site includes all the required components to host the Pan American Games.

With many sports clustered in the area such as Boxing and Indoor Shooting spectators and participants will have substantial opportunities to enjoy a variety of sports in a compact region.

> **SPORT & VENUE SPECIFICATIONS**

CURRENT STATUS
<ul style="list-style-type: none"> <li>Existing</li> <li>Current/Future owner: Oshawa Skeet and Gun Club</li> </ul>
VENUE HIGHLIGHTS
<ul style="list-style-type: none"> <li>Meets all International Federation specifications</li> <li>Seating Capacity: 1,500</li> <li>Distance from village: 40 minutes / 74 km</li> <li>Parking spaces: over 500</li> </ul>
CURRENT AND POST GAMES USE
<ul style="list-style-type: none"> <li>The OSGC is a multidiscipline shooting facility featuring Skeet, International Skeet, Trap, Wobble Trap, 5-Stand, and Sporting Clays.</li> <li>Hosting Experience: <ul style="list-style-type: none"> <li>2008 Ontario Provincial Skeet Championships</li> <li>2008 Canadian Open Championships</li> <li>2002 Ontario Provincial Skeet Championships</li> <li>2002 Canadian Open Skeet Championships.</li> <li>2002 Canadian Open Sporting Clays Championships</li> <li>2002 Canadian FITASC Championships (Federation Internationale de Tir Aux Armes Sportives de Chasse)</li> </ul> </li> </ul>



**SPORT:**  
**TABLE TENNIS**

**VENUE: Centennial Community Centre**

This facility offers a multi-sport environment for sport and recreation users looking to get active and participate in sport. In addition to the arena, the facility has a 25 metre pool, fitness centre and meeting rooms.

Within the 2,500 seat main arena hosting the table tennis competition and the adjacent area housing the required warm-up and training area, this venue will provide a compact setting for the fast-paced action of this racquet sport.

Given the close proximity to the competitive venues for Water Polo it will create a cluster of sports, enhancing spectator opportunities during the Games.

> **SPORT & VENUE SPECIFICATIONS**

CURRENT STATUS
<ul style="list-style-type: none"> <li>Existing</li> <li>Built 1972, renovated 1999</li> <li>Current/Future owner: Town of Markham</li> </ul>
VENUE HIGHLIGHTS
<ul style="list-style-type: none"> <li>Meets all International Federation specifications</li> <li>Seating Capacity: 2,500</li> <li>Distance from village: 27 minutes / 29 km</li> <li>Parking spaces: over 1,000</li> </ul>
CURRENT AND POST GAMES USE
<ul style="list-style-type: none"> <li>The facility will continue to serve the residents and athletes in the area, seeking enhanced sport and recreation opportunities.</li> </ul>



> **COMPETITION SCHEDULE**

JULY																		
Day	Thu	Fri	Sat	Sun	Mon	Tues	Wed	Thu	Fri	Sat	Sun	Mon	Tue	Wed	Thu	Fri	Sat	Sun
Date	9	10	11	12	13	14	15	16	17	18	19	20	21	22	23	24	25	26
Table Tennis			●	●	●	●	●	●	●	●								

● Competition ● Finals (may include competitions on these days)



> COMPETITION SITE PLAN

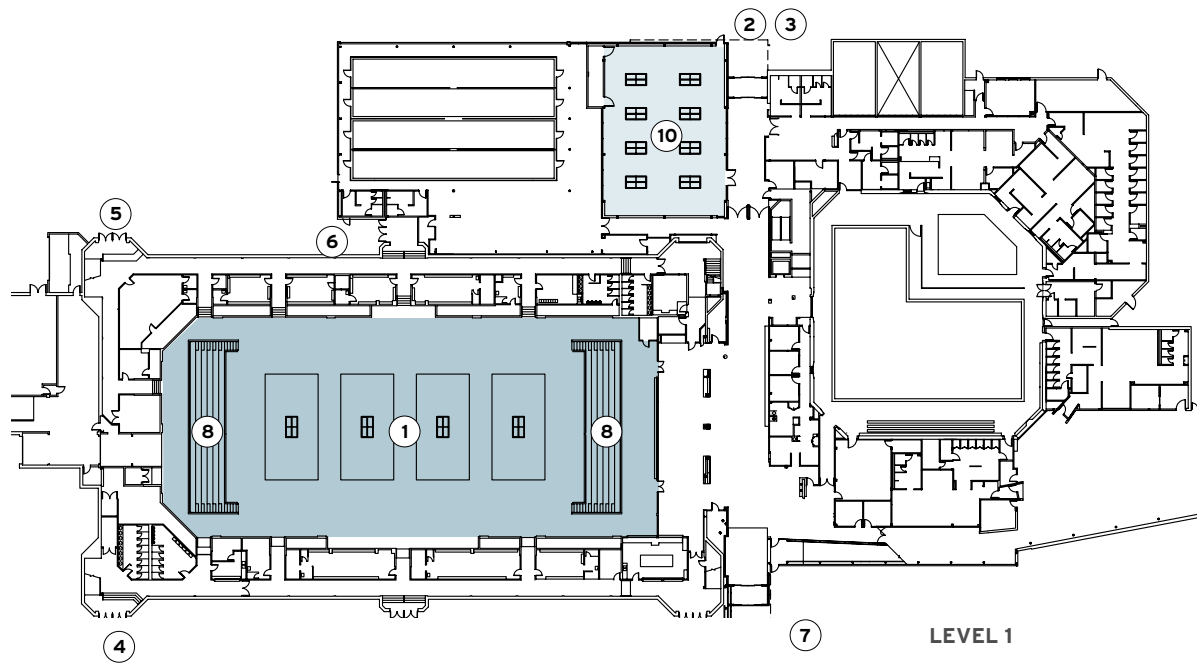
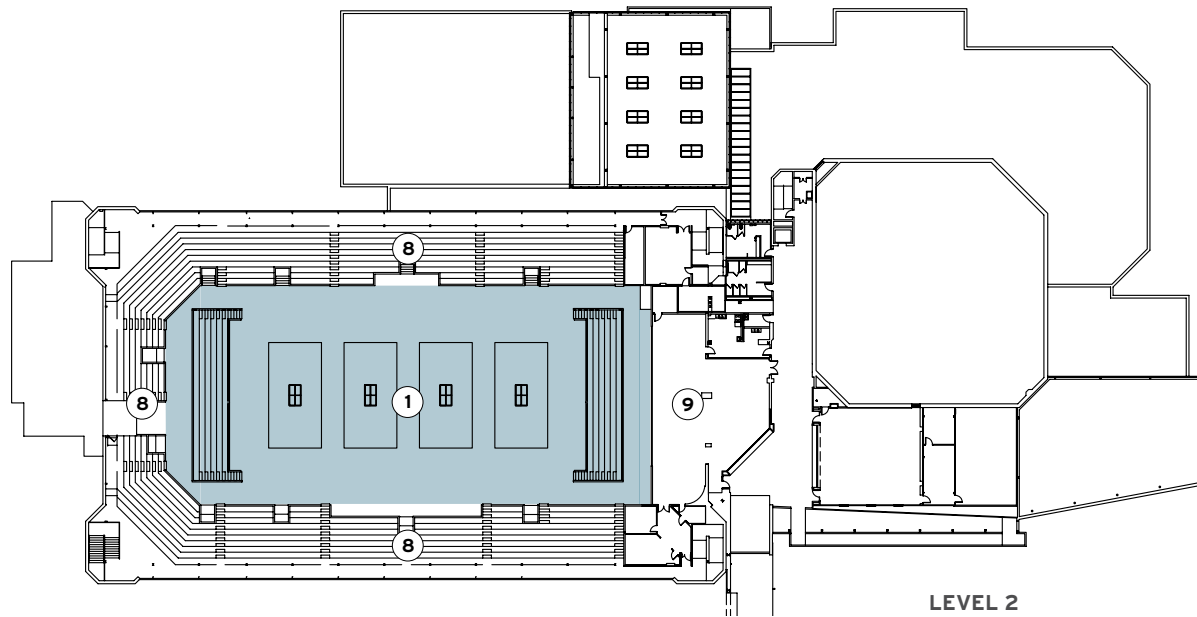

**LEGEND**

- |  |                             |
|--|-----------------------------|
| 1 COMPETITION FIELD OF PLAY                  | 7 ENTRY/EXIT FOR SPECTATORS |
| 2 ENTRY/EXIT FOR ATHLETES AND TEAM OFFICIALS | 8 SPECTATOR SEATING         |
| 3 ENTRY/EXIT FOR TECHNICAL OFFICIALS         | 9 SPECTATOR AMENITIES       |
| 4 ENTRY/EXIT FOR MEDIA                       | 10 WARM UP AREA             |
| 5 ENTRY/EXIT FOR SPONSORS                    |                             |
| 6 ENTRY/EXIT FOR STAFF                       |                             |

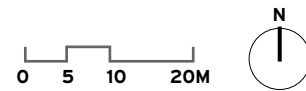



**SPORT:**  
**TAEKWONDO**

**VENUE:** Hershey Centre

The Hershey Centre is a multi-sport facility which showcases local, national and international talent in excellent facilities including arenas, spectator facilities, gymnasia and a FIFA regulation indoor turf field.

As a combative sports hub, the facility will include the competitions of Judo and Taekwondo with room for 5,400 spectators ready to appreciate the grace, agility and strength of these competitors.



> **SPORT & VENUE SPECIFICATIONS**

**CURRENT STATUS**

- Existing
- Built in 1998
- Current/Future Owner: City of Mississauga

**VENUE HIGHLIGHTS**

- Meets all International Federation specifications
- Seating Capacity: 5,400
- Distance from village: 27 minutes/32 km
- Parking spaces: 1,920

**CURRENT AND POST GAMES USE**

- This important multi-sport facility will continue to serve the needs of community users and high performance athletes.
- Hosting Experience:
  - 2009 Harlem Globetrotters
  - 2008 World Junior Championship of Hockey
  - 2007 - Present: Ontario Hockey League Mississauga St Michael's Majors
  - 1998-2007: OHL Mississauga Ice Dogs



> **COMPETITION SCHEDULE**

JULY																		
Day	Thu	Fri	Sat	Sun	Mon	Tues	Wed	Thu	Fri	Sat	Sun	Mon	Tue	Wed	Thu	Fri	Sat	Sun
Date	9	10	11	12	13	14	15	16	17	18	19	20	21	22	23	24	25	26
Taekwondo			●	●	●	●												

● Finals (may include competitions on these days)

> COMPETITION SITE PLAN

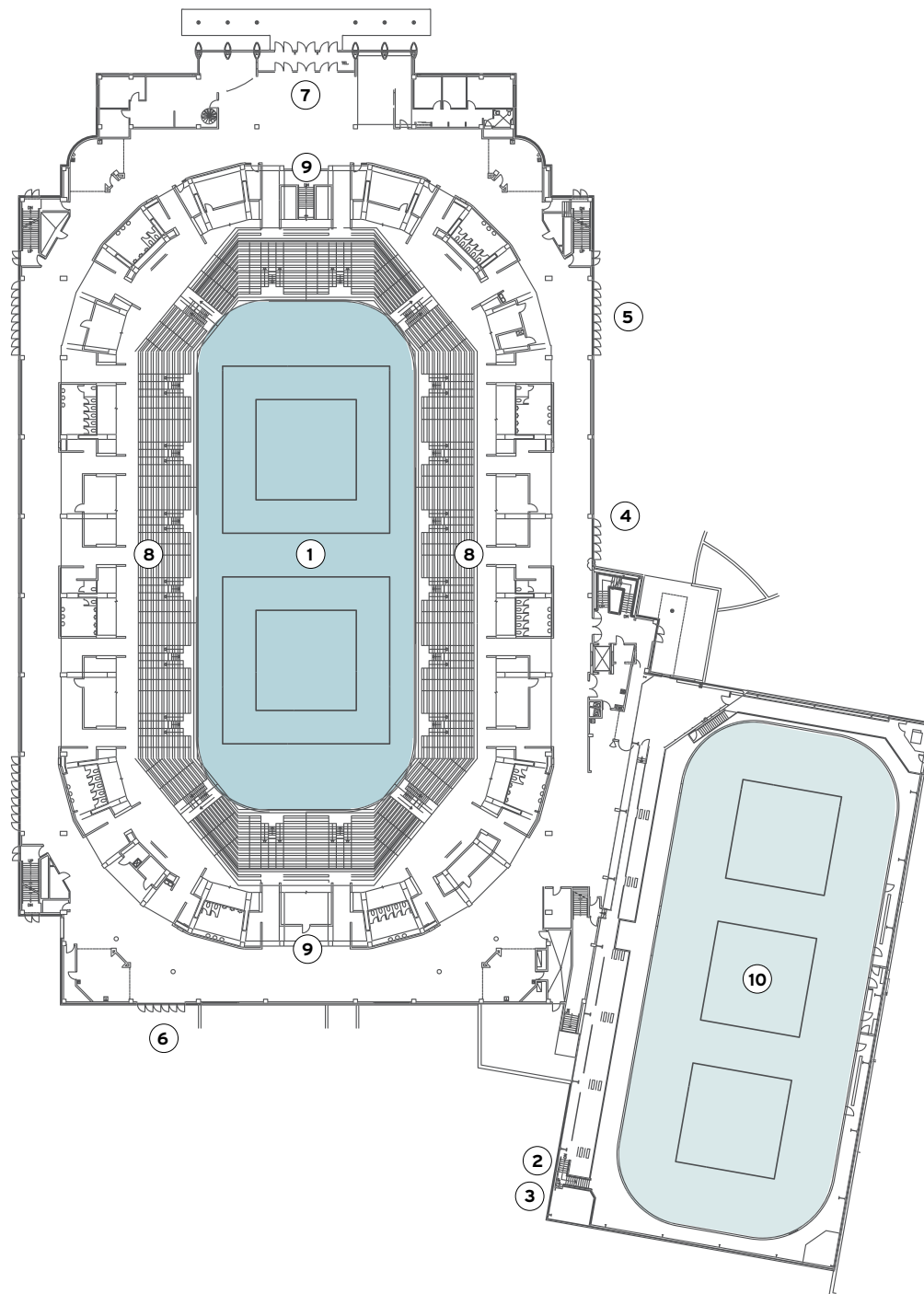

**LEGEND**

- |  |                             |
|--|-----------------------------|
| 1 COMPETITION FIELD OF PLAY                  | 7 ENTRY/EXIT FOR SPECTATORS |
| 2 ENTRY/EXIT FOR ATHLETES AND TEAM OFFICIALS | 8 SPECTATOR SEATING         |
| 3 ENTRY/EXIT FOR TECHNICAL OFFICIALS         | 9 SPECTATOR AMENITIES       |
| 4 ENTRY/EXIT FOR MEDIA                       | 10 WARM UP AREA             |
| 5 ENTRY/EXIT FOR SPONSORS                    |                             |
| 6 ENTRY/EXIT FOR STAFF                       |                             |

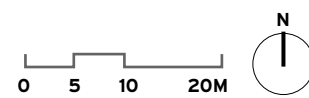



## SPORT: TENNIS

### VENUE: The Rexall Centre

The Rexall Centre has been built not only as an international Tennis centre but also with the local community in mind. The park-like setting provides dining, shopping and interactive activities to add to the Tennis experience.

The focus of the Rexall Centre is the 16 Tennis courts built adjacent to a 12,500 seat grandstand court. It also provides year-round training facilities, community programming and is home to Tennis Canada.

The facility hosts the WTA/ATP Rogers Cup, classified as a Premier event under the Sony Ericsson WTA Tour.



### > SPORT & VENUE SPECIFICATIONS

#### CURRENT STATUS

- Existing
- Built in 2004
- Current/Future Owner: Tennis Canada

#### VENUE HIGHLIGHTS

- Meets all International Federation specifications
- Seating Capacity: 12,500
- Distance from village: 27 minutes/39 km
- Parking spaces: 11,000

#### CURRENT AND POST GAMES USE

- Canada's National Tennis Centre
- Hosting Experience:
  - Bi-annual Annual ATP Tennis Masters Canada Rogers Cup
  - Bi-annual WTA Rogers Cup
  - The Rogers Cup is classified as a Premier event under the Sony Ericsson WTA Tour.



### > COMPETITION SCHEDULE

JULY																		
Day	Thu	Fri	Sat	Sun	Mon	Tues	Wed	Thu	Fri	Sat	Sun	Mon	Tue	Wed	Thu	Fri	Sat	Sun
Date	9	10	11	12	13	14	15	16	17	18	19	20	21	22	23	24	25	26
Tennis					●	●	●	●	●	●	●	●	●	●	●	●		

- Competition
- Finals (may include competitions on these days)

> COMPETITION SITE PLAN

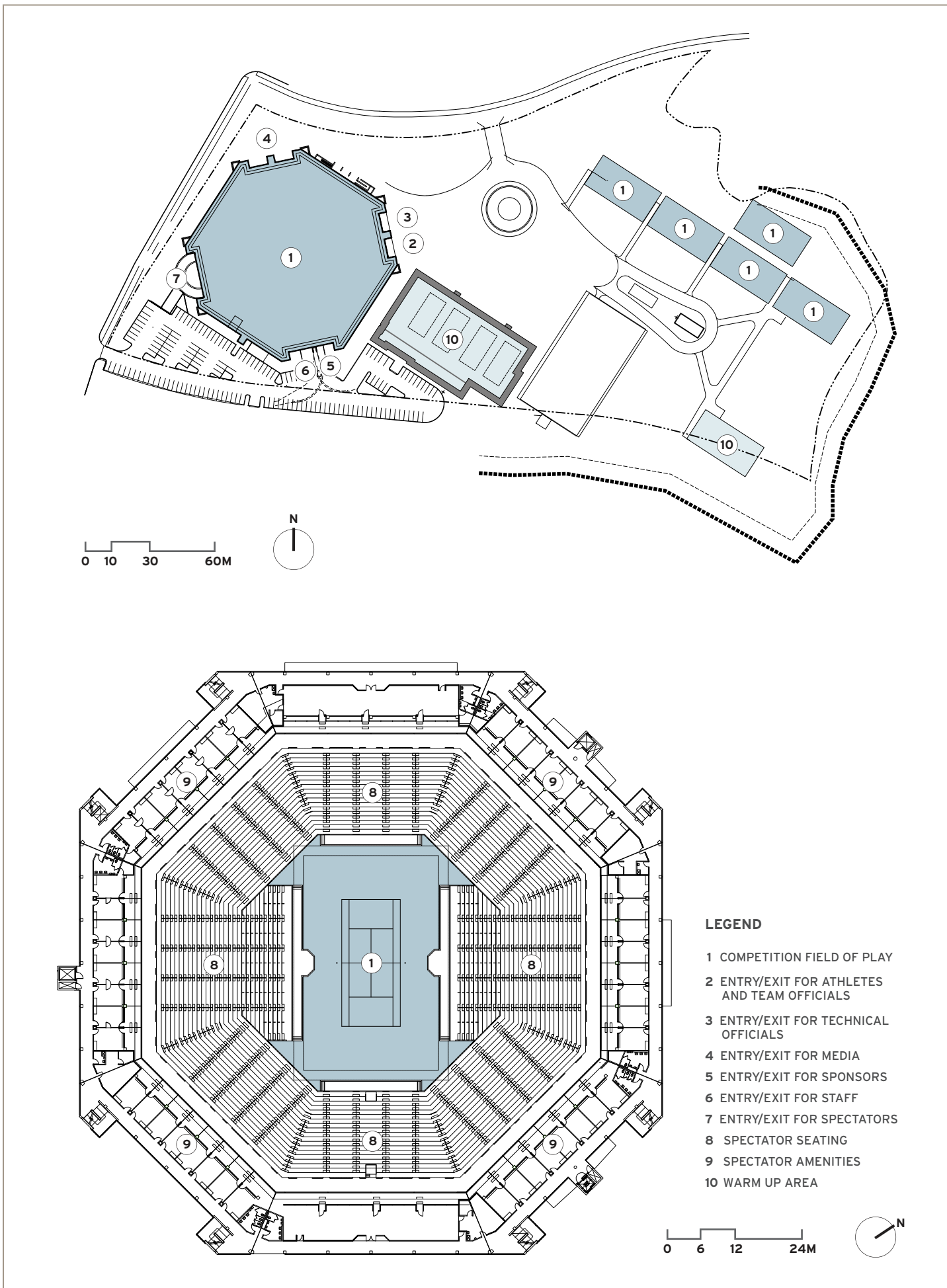



## SPORT: TRIATHLON

### VENUE: Ontario Place

Home to the 2000 ITU Toronto World Cup, the Triathlon course is centrally located within Ontario Place and Exhibition Place on the Toronto waterfront, minutes from the Pan American Village.

Triathlon will be part of a significant cluster of sport venues around Exhibition Place, including Karate, Gymnastics, Beach Volleyball, Road Cycling, Football, and Handball.

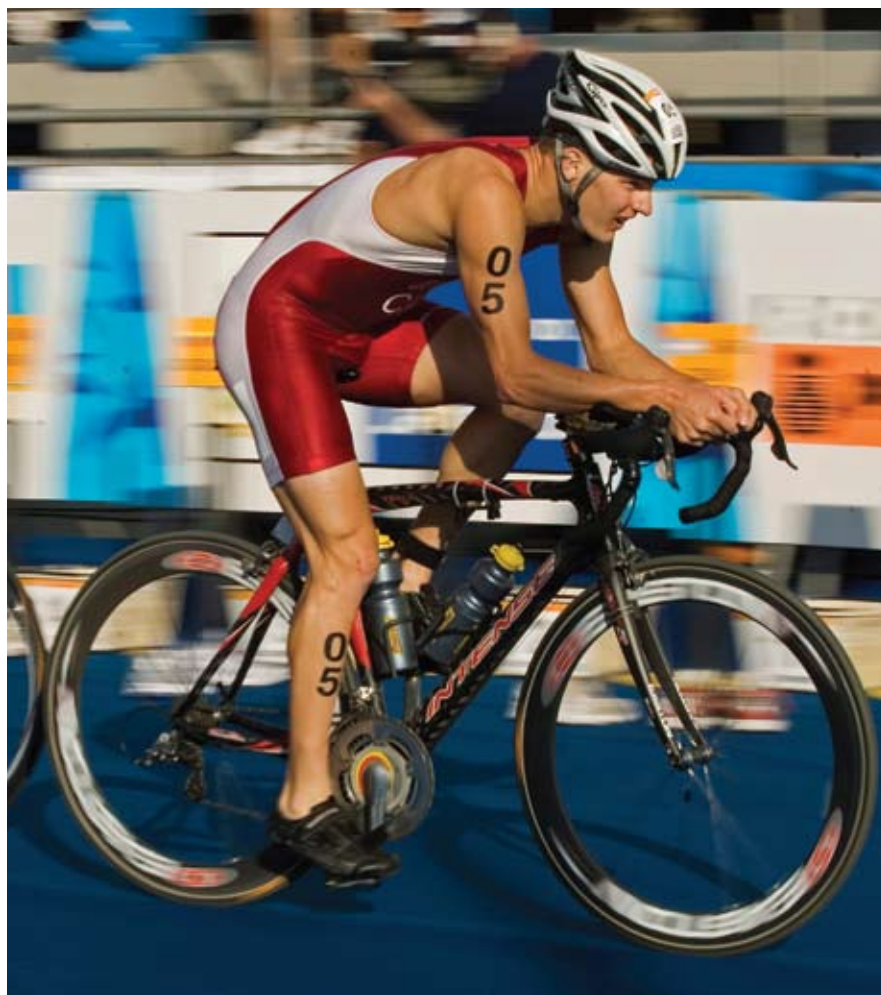

### > SPORT & VENUE SPECIFICATIONS

#### CURRENT STATUS

- Existing
- Current/Future Owner: Province of Ontario

#### VENUE HIGHLIGHTS

- Meets all International Federation specifications
- Seating Capacity: 2,500
- Distance from village: 5 minutes/6 km
- Parking spaces: 7,000

#### CURRENT AND POST GAMES USE

- Ontario Place is an internationally acclaimed cultural, leisure and entertainment venue. The complex extends throughout three man-made islands along the Lake Ontario waterfront.
- Hosting Experience:
  - 2006 to Present - Annual Rogers Chinese Lantern Festival
  - Annual Canadian International Air Show
  - 2000 ITU Toronto World Cup Triathlon



### > COMPETITION SCHEDULE

JULY																		
Day	Thu	Fri	Sat	Sun	Mon	Tues	Wed	Thu	Fri	Sat	Sun	Mon	Tue	Wed	Thu	Fri	Sat	Sun
Date	9	10	11	12	13	14	15	16	17	18	19	20	21	22	23	24	25	26
Triathlon			●															

- Finals (may include competitions on these days)

> COMPETITION SITE PLAN

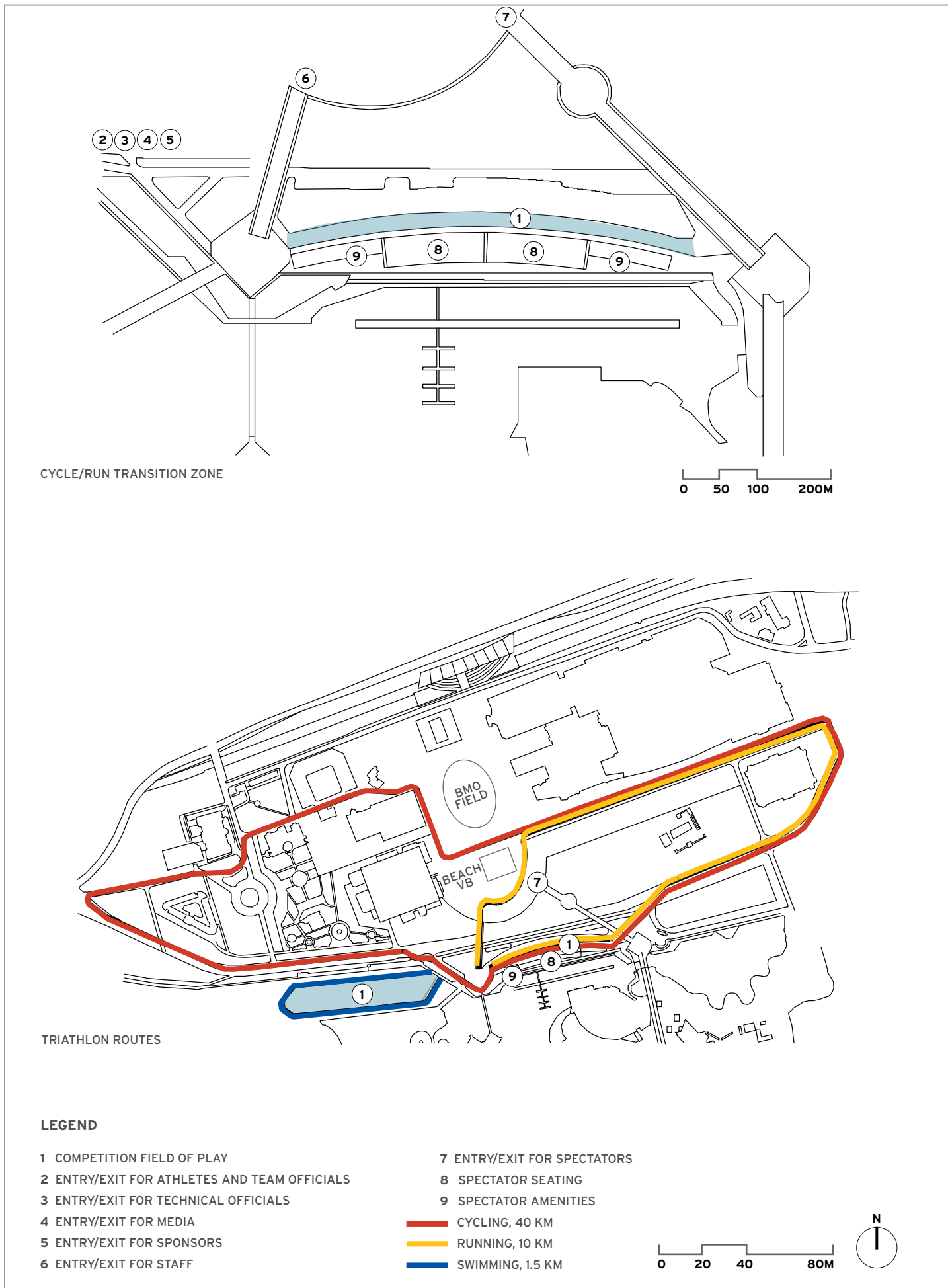

CYCLE/RUN TRANSITION ZONE

0 50 100 200M

TRIATHLON ROUTES

**LEGEND**

- |  |                             |
|--|-----------------------------|
| 1 COMPETITION FIELD OF PLAY                  | 7 ENTRY/EXIT FOR SPECTATORS |
| 2 ENTRY/EXIT FOR ATHLETES AND TEAM OFFICIALS | 8 SPECTATOR SEATING         |
| 3 ENTRY/EXIT FOR TECHNICAL OFFICIALS         | 9 SPECTATOR AMENITIES       |
| 4 ENTRY/EXIT FOR MEDIA                       |                             |
| 5 ENTRY/EXIT FOR SPONSORS                    | — CYCLING, 40 KM            |
| 6 ENTRY/EXIT FOR STAFF                       | — RUNNING, 10 KM            |
|  | — SWIMMING, 1.5 KM          |

0 20 40 80M





**SPORT:**  
**VOLLEYBALL**  
**INDOOR**

**VENUE: Copps Coliseum**

At 17,500 seats, Copps Coliseum represents the 3rd largest indoor facility for the Games and will provide Volleyball athletes and spectators with one of the largest and most adaptable venues in the Games.

During the Games, its close proximity to the Athletics, Football and Track Cycling venues will create a significant cluster of venues for three important sports within one km of each other making it easy for athletes and spectators to witness sport excellence at its best.



> **SPORT & VENUE SPECIFICATIONS**

CURRENT STATUS
<ul style="list-style-type: none"> <li>Existing</li> <li>Built in 1985</li> <li>Current/Future Owner: City of Hamilton</li> </ul>
VENUE HIGHLIGHTS
<ul style="list-style-type: none"> <li>Meets all International Federation specifications</li> <li>Seating Capacity: 17,500</li> <li>Distance from village: 45 minutes/68 km</li> <li>Parking spaces: 8,400</li> </ul>
CURRENT AND POST GAMES USE
<ul style="list-style-type: none"> <li>Internationally recognized as a superior professional sports facility, Copps Coliseum can comfortably accommodate large scale events as its configuration can be easily adapted to suit diverse requirements.</li> <li>Hosting Experience:             <ul style="list-style-type: none"> <li>1996 - Present: American Hockey League Hamilton Bulldogs</li> <li>Canadian Figure Skating Championships</li> <li>NHL Hockey Games</li> <li>WCF World Curling Championships</li> <li>FIBA World Basketball Championship</li> <li>IIHF World Junior Hockey Championships</li> <li>IJF World Judo Championships</li> </ul> </li> </ul>



> **COMPETITION SCHEDULE**

JULY																		
Day	Thu	Fri	Sat	Sun	Mon	Tues	Wed	Thu	Fri	Sat	Sun	Mon	Tue	Wed	Thu	Fri	Sat	Sun
Date	9	10	11	12	13	14	15	16	17	18	19	20	21	22	23	24	25	26
VENUE: COPPS COLISEUM/MCMASTER UNIVERSITY																		
Volleyball Indoor (W)			●	●	●		●	●										
Volleyball Indoor (M)											●	●	●		●	●		
VENUE: EXHIBITION PLACE																		
Volleyball Beach					●	●	●	●	●	●	●	●						

● Competition    ● Finals (may include competitions on these days)

> COMPETITION SITE PLANS

COPPS COLISEUM - VOLLEYBALL INDOOR

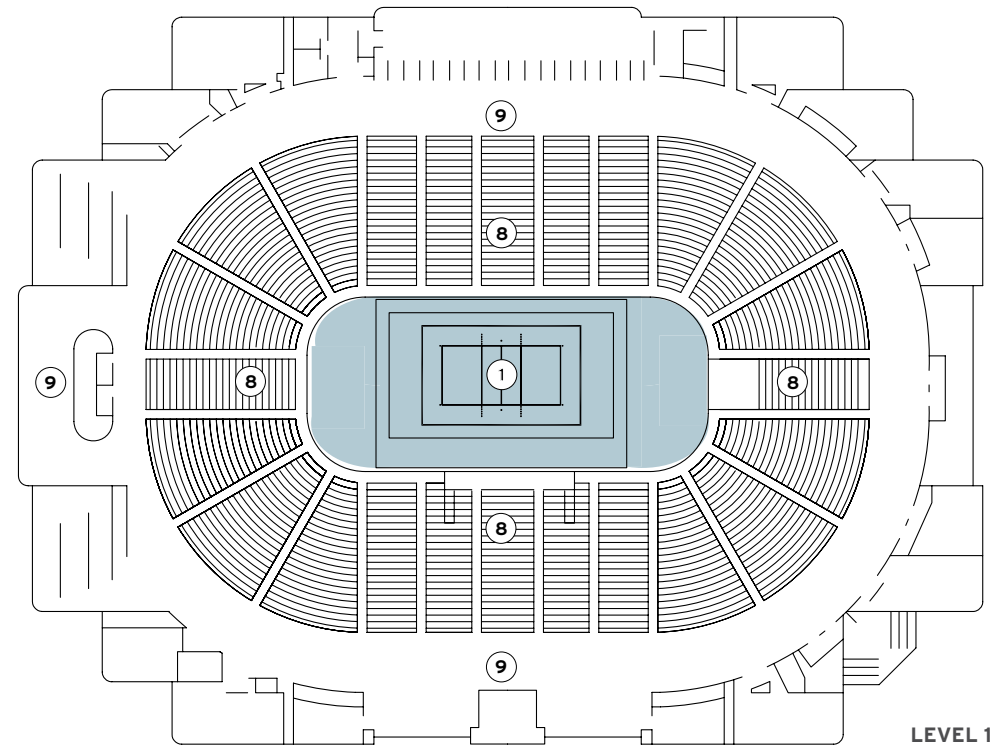
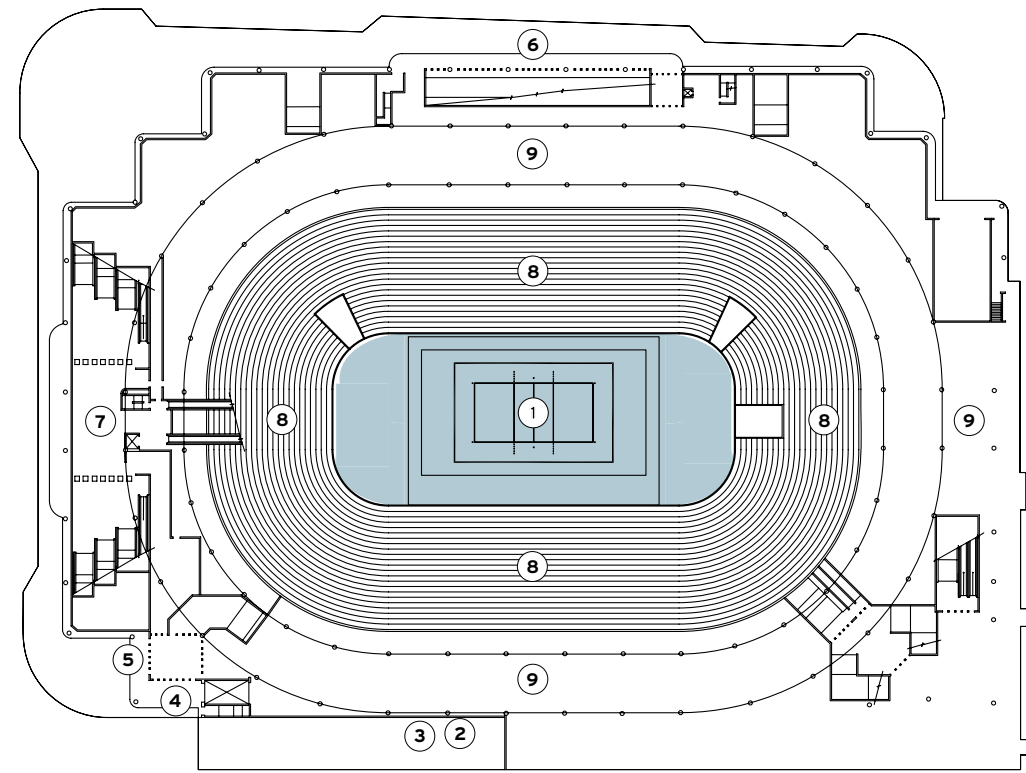

LEGEND

- |  |                             |
|--|-----------------------------|
| 1 COMPETITION FIELD OF PLAY                  | 7 ENTRY/EXIT FOR SPECTATORS |
| 2 ENTRY/EXIT FOR ATHLETES AND TEAM OFFICIALS | 8 SPECTATOR SEATING         |
| 3 ENTRY/EXIT FOR TECHNICAL OFFICIALS         | 9 SPECTATOR AMENITIES       |
| 4 ENTRY/EXIT FOR MEDIA                       |                             |
| 5 ENTRY/EXIT FOR SPONSORS                    |                             |
| 6 ENTRY/EXIT FOR STAFF                       |                             |

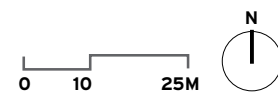

EXHIBITION PLACE - VOLLEYBALL BEACH

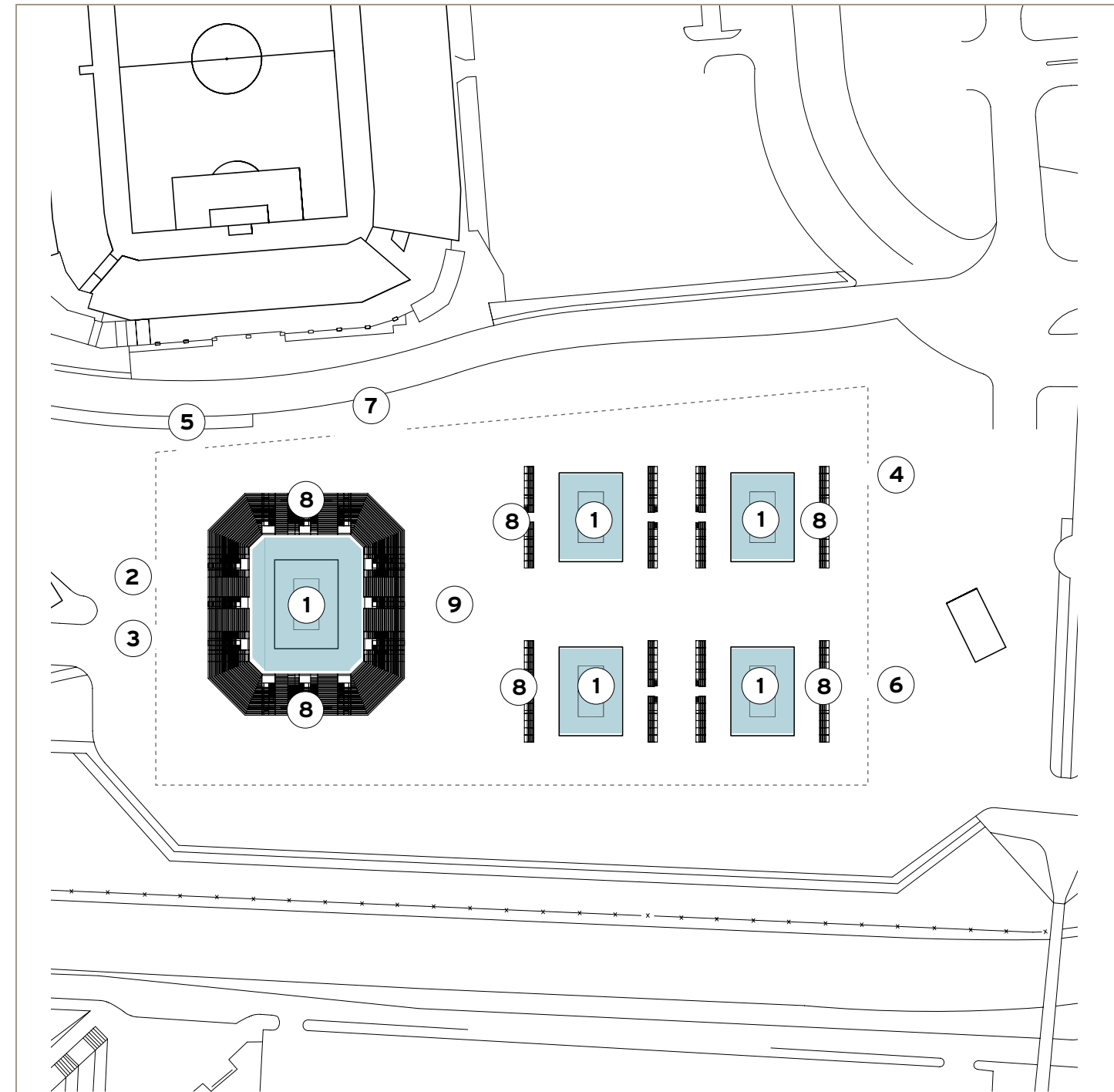

LEGEND

- |  |                             |
|--|-----------------------------|
| 1 COMPETITION FIELD OF PLAY                  | 7 ENTRY/EXIT FOR SPECTATORS |
| 2 ENTRY/EXIT FOR ATHLETES AND TEAM OFFICIALS | 8 SPECTATOR SEATING         |
| 3 ENTRY/EXIT FOR TECHNICAL OFFICIALS         | 9 SPECTATOR AMENITIES       |
| 4 ENTRY/EXIT FOR MEDIA                       |                             |
| 5 ENTRY/EXIT FOR SPONSORS                    |                             |
| 6 ENTRY/EXIT FOR STAFF                       |                             |

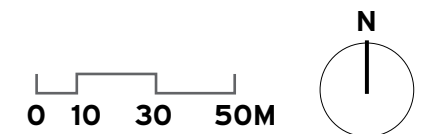



**SPORT:**  
**VOLLEYBALL**  
**BEACH**

**VENUE: Exhibition Place**

Beach Volleyball will make its home at a new 5,000 seat facility at Exhibition Place, a lakefront complex that is a vibrant destination for public celebrations, festivals and events.

One of the most exciting sports on the program, Beach Volleyball will take centre stage amongst a significant cluster of sports for the Games, five minutes from the Pan American Village.

Sports competing at Exhibition Place also include Karate, Gymnastics, Handball, Triathlon, Football, and Road Cycling.

> **SPORT & VENUE SPECIFICATIONS**

CURRENT STATUS
<ul style="list-style-type: none"> <li>• Temporary facility</li> <li>• Ready for 2015</li> <li>• Current/Future owner: N/A</li> </ul>
VENUE HIGHLIGHTS
<ul style="list-style-type: none"> <li>• Meets all International Federation specifications</li> <li>• 1 stadium court with 4 adjacent courts</li> <li>• Seating Capacity: 5,000</li> <li>• Distance from village: 5 minutes / 6 km</li> <li>• Parking spaces: 7,400</li> </ul>
CURRENT AND POST GAMES USE
<ul style="list-style-type: none"> <li>• Exhibition Place is a mixed-use property on the Toronto shore of Lake Ontario, featuring expo, trade, and banquet centres, theater and music buildings, parkland, sports facilities, and a number of civic, provincial, and national historic sites.</li> <li>• Hosting Experience:             <ul style="list-style-type: none"> <li>• 2003 Dalai Lama's Visit</li> <li>• 2002 Royal Visit / Queen Elizabeth II</li> <li>• 2002 World Youth Day / Pope John Paul II</li> <li>• Annual - Present: Canadian National Exhibition (over 1 million annual visitors)</li> </ul> </li> </ul>



**SPORT:**  
**WEIGHTLIFTING**

**VENUE: Roy Thomson Hall**

Roy Thomson Hall, located in the heart of the Toronto theatre district, has a unique curvilinear exterior design and sloping glass canopy that make this concert hall one of Toronto's landmarks.

This venue, which has hosted some of the greatest musical performers in the world, will be converted into one of the most unique weightlifting venues, including separate warm up and training areas in an adjacent area of the facility. The warm up area is less than 10 metres from the competition field of play.

> **SPORT & VENUE SPECIFICATIONS**

CURRENT STATUS
<ul style="list-style-type: none"> <li>• Existing</li> <li>• Built in 1982</li> <li>• Current/Future owner: City of Toronto</li> </ul>
VENUE HIGHLIGHTS
<ul style="list-style-type: none"> <li>• Meets all International Federation specifications</li> <li>• Seating Capacity: 2,500</li> <li>• Distance from village: 5 minutes / 3 km</li> <li>• Parking spaces: over 500</li> </ul>
CURRENT AND POST GAMES USE
<ul style="list-style-type: none"> <li>• Roy Thomson Hall is home to the Toronto Symphony Orchestra and hosts multiple concerts and events annually including the Toronto International Film Festival</li> </ul>



> **COMPETITION SCHEDULE**

JULY																		
Day	Thu	Fri	Sat	Sun	Mon	Tues	Wed	Thu	Fri	Sat	Sun	Mon	Tue	Wed	Thu	Fri	Sat	Sun
Date	9	10	11	12	13	14	15	16	17	18	19	20	21	22	23	24	25	26
Weightlifting				•	•	•	•	•										

• Finals (may include competitions on these days)



> COMPETITION SITE PLAN

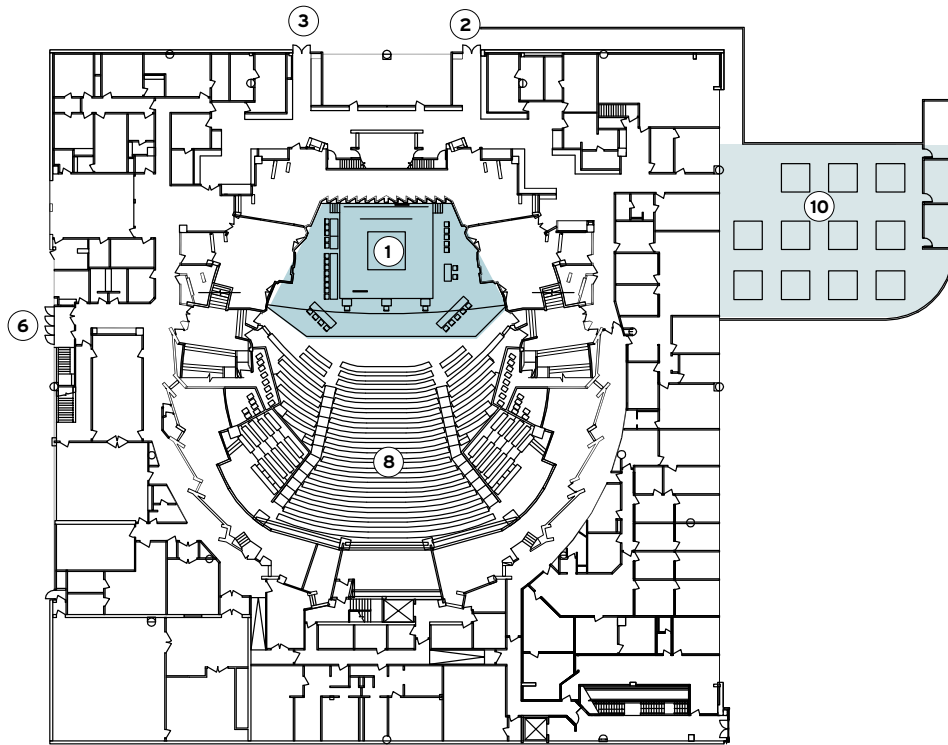
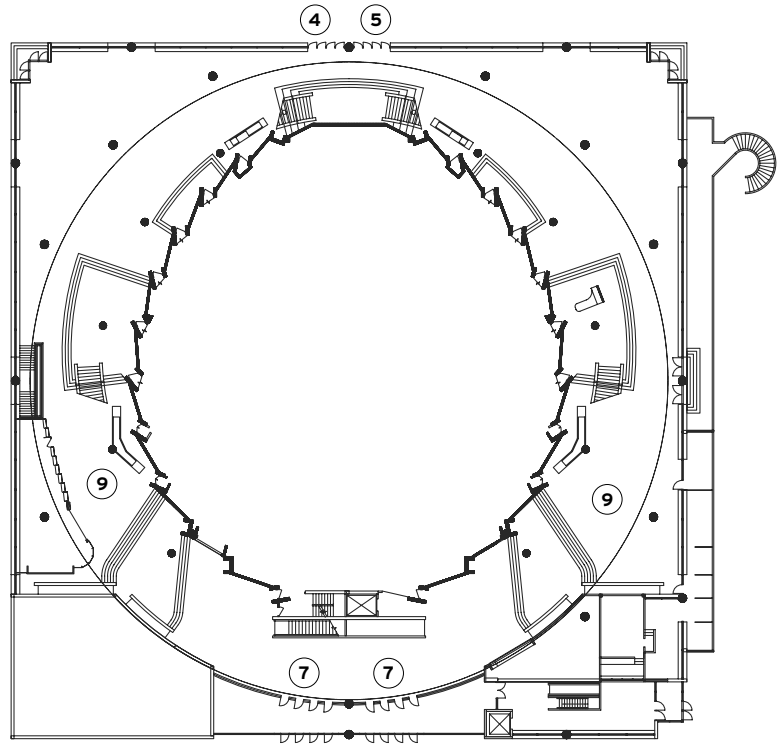

**LEGEND**

- |  |                             |
|--|-----------------------------|
| 1 COMPETITION FIELD OF PLAY                  | 7 ENTRY/EXIT FOR SPECTATORS |
| 2 ENTRY/EXIT FOR ATHLETES AND TEAM OFFICIALS | 8 SPECTATOR SEATING         |
| 3 ENTRY/EXIT FOR TECHNICAL OFFICIALS         | 9 SPECTATOR AMENITIES       |
| 4 ENTRY/EXIT FOR MEDIA                       | 10 WARM UP AREA             |
| 5 ENTRY/EXIT FOR SPONSORS                    |                             |
| 6 ENTRY/EXIT FOR STAFF                       |                             |

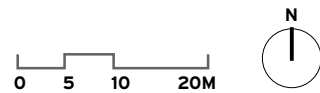



## SPORT: WRESTLING

### VENUE: Powerade Centre

This venue is home to major sports teams as well as community groups and grass-roots sports. In addition to its 5,000 seat arena, the facility includes two arenas and five illuminated baseball diamonds, a rugby field, and a cricket pitch.

The sport of Wrestling will find its home during the Games within this large capacity venue with an adjacent warm-up and training venue.



### > SPORT & VENUE SPECIFICATIONS

#### CURRENT STATUS

- Existing
- Built 1998
- Current/Future Owner: City of Brampton

#### VENUE HIGHLIGHTS

- Meets all International Federation specifications
- Seating Capacity: 5,000
- Distance from village: 30 minutes/38 km
- Parking spaces: 1,400

#### CURRENT AND POST GAMES USE

- A significant sport and recreation facility in the region, the facility is the home of the Brampton Battalion of the Ontario Hockey League, host to major concerts and events and provides a venue for significant community sport and recreation.
- Hosting Experience:
  - Skate Canada 2009 Synchro Skating Sectionals
  - International Ice Hockey Federation World Junior Exhibition Game
  - Regional and National Skating Championships



### > COMPETITION SCHEDULE

JULY																		
Day	Thu	Fri	Sat	Sun	Mon	Tues	Wed	Thu	Fri	Sat	Sun	Mon	Tue	Wed	Thu	Fri	Sat	Sun
Date	9	10	11	12	13	14	15	16	17	18	19	20	21	22	23	24	25	26
Wrestling														•	•	•	•	

- Finals (may include competitions on these days)

> COMPETITION SITE PLAN

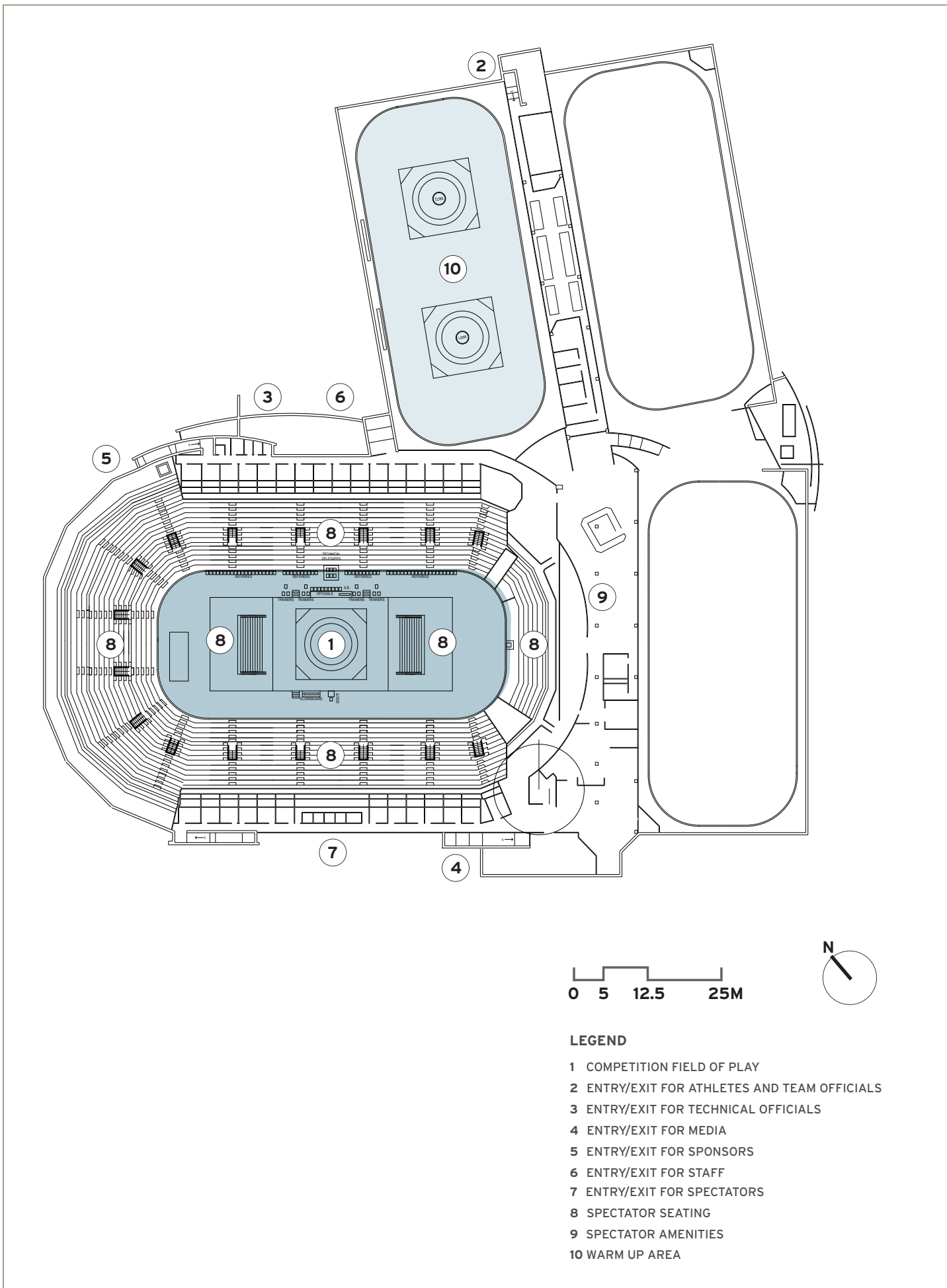

- LEGEND**
- 1 COMPETITION FIELD OF PLAY
  - 2 ENTRY/EXIT FOR ATHLETES AND TEAM OFFICIALS
  - 3 ENTRY/EXIT FOR TECHNICAL OFFICIALS
  - 4 ENTRY/EXIT FOR MEDIA
  - 5 ENTRY/EXIT FOR SPONSORS
  - 6 ENTRY/EXIT FOR STAFF
  - 7 ENTRY/EXIT FOR SPECTATORS
  - 8 SPECTATOR SEATING
  - 9 SPECTATOR AMENITIES
  - 10 WARM UP AREA





**SPORT:**  
**BASEBALL**

**VENUE: Rogers Centre**

The Rogers Centre, located minutes from the Pan American Village, will be the principal Baseball venue for the Games. Often referred to as the “eight wonder of the world”, the facility, with its retractable roof, will offer a Baseball schedule that is sheltered from weather delays, and when open, will provide the single best view of Toronto’s CN Tower. The Rogers Centre will also host the Opening and Closing Ceremonies for the Games.

As the home of Major League Baseball’s Toronto Blue Jays, and the 2009 World Baseball Classic, this venue will provide all participants with a unique setting that exceeds the international specification for the Games, and includes the highest broadcast and technological standards for a sports event.

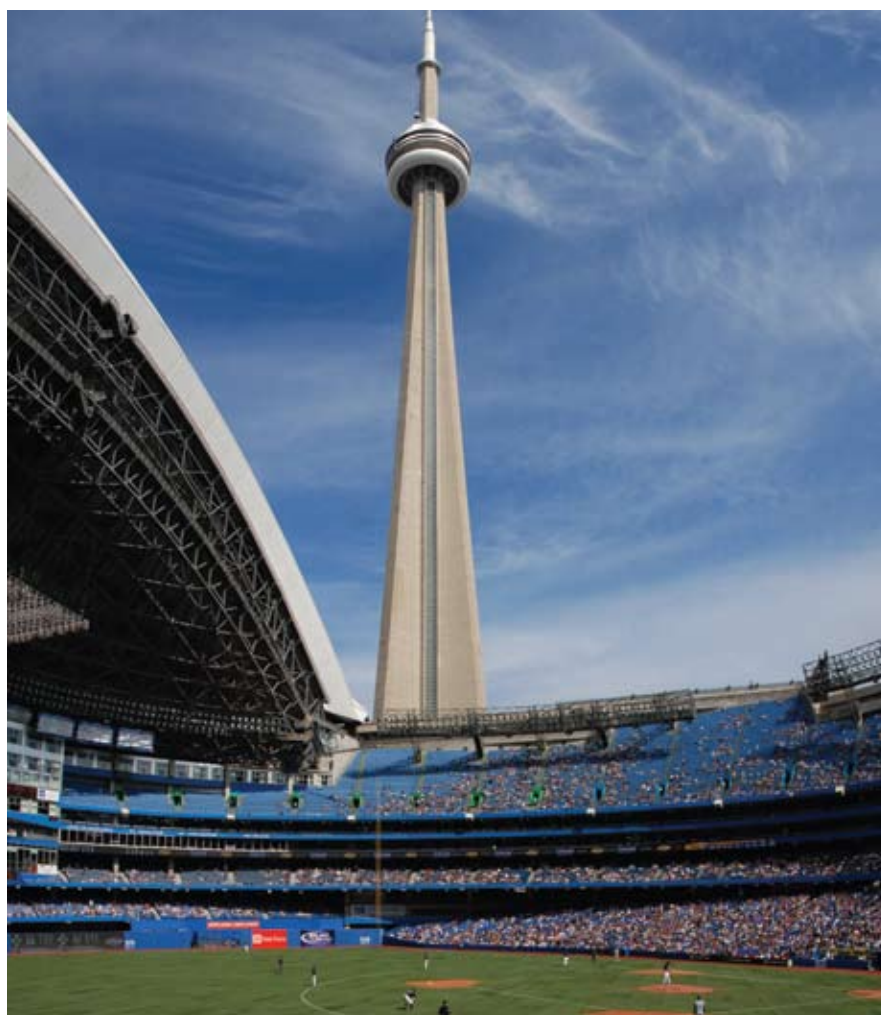

**> SPORT & VENUE SPECIFICATIONS**

CURRENT STATUS
<ul style="list-style-type: none"> <li>Existing</li> <li>Built in 1989</li> <li>Current/Future Owner: Rogers Communications Inc.</li> </ul>
VENUE HIGHLIGHTS
<ul style="list-style-type: none"> <li>Meets all International Federation specifications</li> <li>Seating Capacity: 46,000</li> <li>Distance from village: 5 minutes/3 km</li> <li>Parking spaces: over 17,500</li> </ul>
CURRENT AND POST GAMES USE
<ul style="list-style-type: none"> <li>Roger Centre facility’s capacity ranges from 5,000 to 60,000 for sports events, concerts, family shows, trade shows and conventions.</li> <li>Hosting Experience:               <ul style="list-style-type: none"> <li>1989 - Present: MLB’s Toronto Blue Jays</li> <li>2009 World Baseball Classic</li> <li>2008 1st NFL Game in Canada</li> <li>1992 &amp; 1993 MLB World Series</li> <li>1991 MLB All Star Game.</li> </ul> </li> </ul>

**> COMPETITION SCHEDULE**

JULY																		
Day	Thu	Fri	Sat	Sun	Mon	Tues	Wed	Thu	Fri	Sat	Sun	Mon	Tue	Wed	Thu	Fri	Sat	Sun
Date	9	10	11	12	13	14	15	16	17	18	19	20	21	22	23	24	25	26
Baseball						●	●	●	●	●	●	●						

● Competition    ● Finals (may include competitions on these days)

> COMPETITION SITE PLAN - ROGERS CENTRE

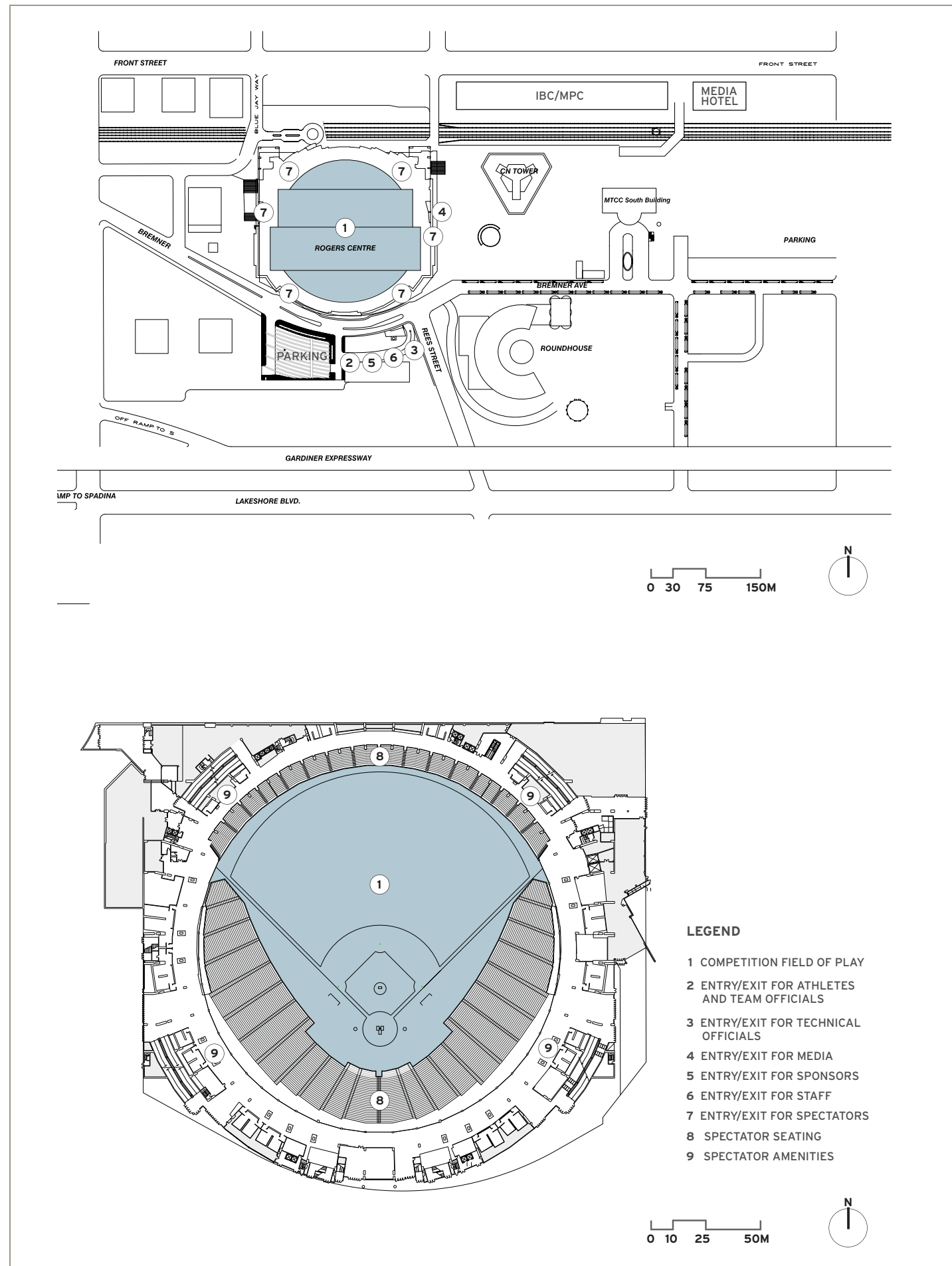

> COMPETITION SITE PLAN - RICHMOND GREEN SPORTS CENTRE AND PARK

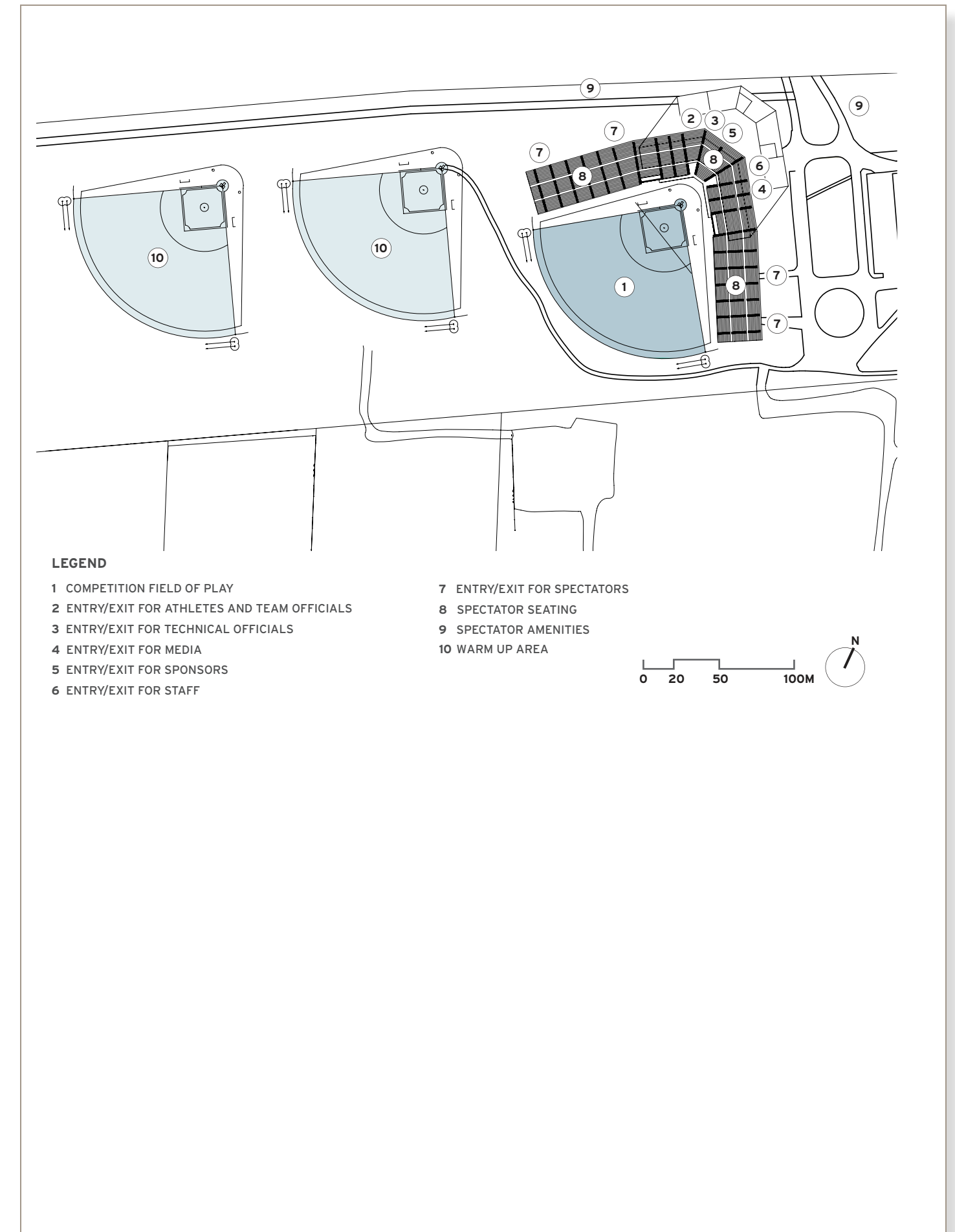



## SPORT: BASEBALL

### VENUE: Richmond Green Sports Centre and Park

Richmond Green Sports Centre and Park is an existing multi-sport complex, including 26,000 sq. ft. of indoor sport facilities to support outdoor fields for baseball, softball, football, lawn bowling, roller sports and park space.

This exciting facility, identified as the secondary venue for baseball - supporting the Rogers Centre as the principal venue - combines the needs of needs of a high performance athlete with a significant community asset capable of hosting a major international competition such as the 2015 Pan American Games.



#### > SPORT & VENUE SPECIFICATIONS

CURRENT STATUS
• Existing
• Built in 1993
• Current/Future Owner: Town of Richmond Hill
VENUE HIGHLIGHTS
• Meets all International Federation specifications
• Seating Capacity: 10,000
• Distance from village: 28 minutes/32 km
• Parking spaces: over 1,000
CURRENT AND POST GAMES USE
• The facility is an important community asset providing community sport and recreation opportunities to residents.



## SPORT: BOWLING – 10-PIN

### VENUE: Classic Bowl

Classic Bowl is a 6,500 m<sup>2</sup> facility providing 60 lanes of 10-pin bowling, which has previously hosted major Professional Bowlers Association events.

The facility will be transformed into a spectators venue that will allow excellent sightlines to enjoy the crashing of the pins, while providing the athletes with a spectacular setting to demonstrate their skills.

#### > SPORT & VENUE SPECIFICATIONS

CURRENT STATUS
• Existing
• Built in 1991
• Current/Future Owner: Classic Bowl
VENUE HIGHLIGHTS
• Meets all International Federation specifications
• Seating Capacity: 1,000
• Distance from village: 27 minutes/34 km
• Parking spaces: over 500
CURRENT AND POST GAMES USE
• The facility is a significant asset for the sport and is heavily utilized by bowlers of all types from recreational to competitive users.



#### > COMPETITION SCHEDULE

JULY																		
Day	Thu	Fri	Sat	Sun	Mon	Tues	Wed	Thu	Fri	Sat	Sun	Mon	Tue	Wed	Thu	Fri	Sat	Sun
Date	9	10	11	12	13	14	15	16	17	18	19	20	21	22	23	24	25	26
Bowling – 10-Pin												•	•	•	•	•	•	

• Competition    • Finals (may include competitions on these days)



> COMPETITION SITE PLAN

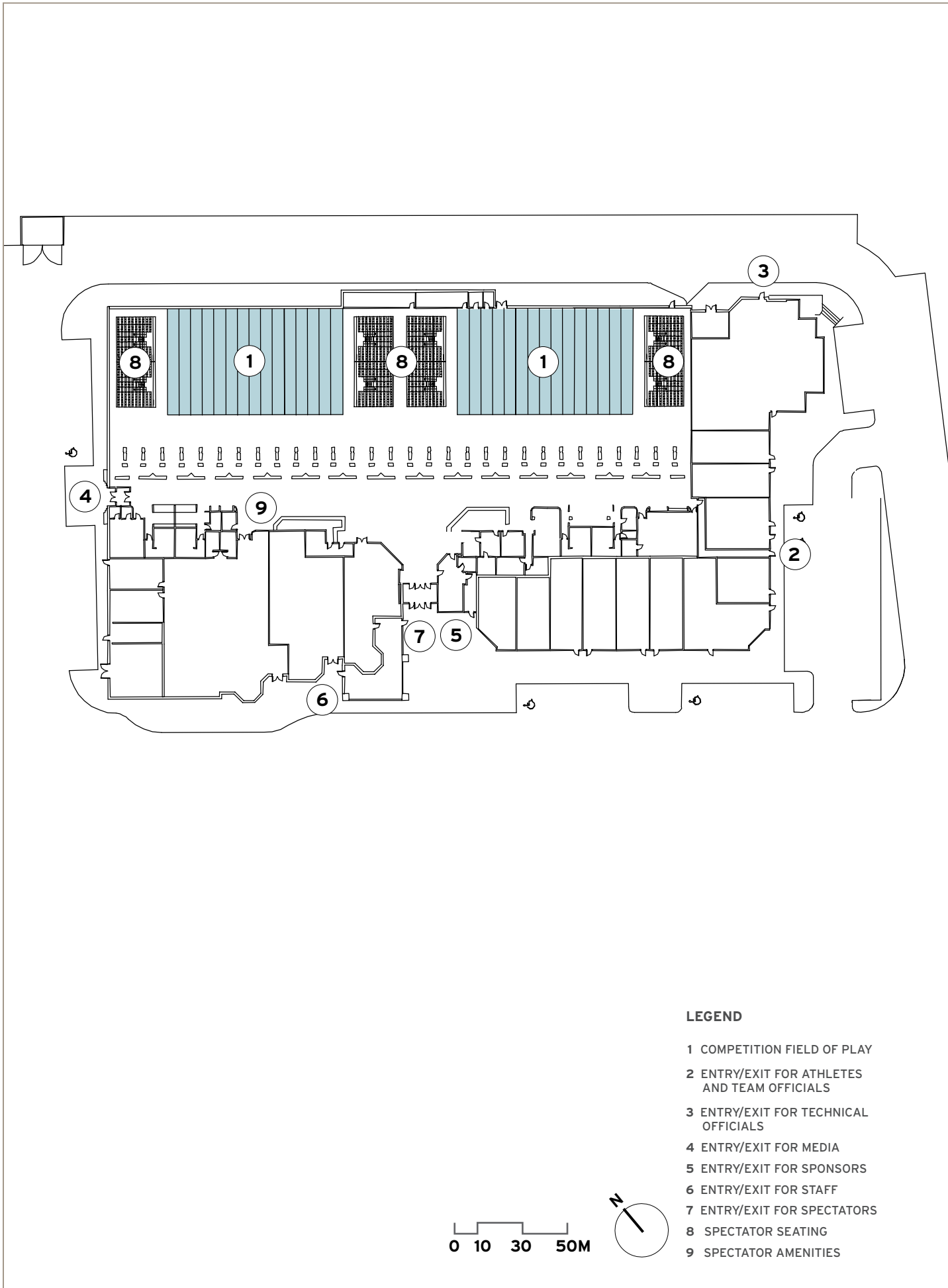

**LEGEND**

- 1 COMPETITION FIELD OF PLAY
- 2 ENTRY/EXIT FOR ATHLETES AND TEAM OFFICIALS
- 3 ENTRY/EXIT FOR TECHNICAL OFFICIALS
- 4 ENTRY/EXIT FOR MEDIA
- 5 ENTRY/EXIT FOR SPONSORS
- 6 ENTRY/EXIT FOR STAFF
- 7 ENTRY/EXIT FOR SPECTATORS
- 8 SPECTATOR SEATING
- 9 SPECTATOR AMENITIES

0 10 30 50M

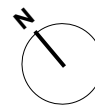



## SPORT: FUTSAL

### VENUE: Goldring Centre for High Performance Sport

The Goldring Centre for High Performance Sport at the University of Toronto is a sports complex that will house research and teaching labs, a strength and conditioning centre, a state-of-the-art sport medicine clinic and a 2,000 seat multi-sport field house.

The venue will house the Futsal competition – an exciting fast-paced football sport sure to revel in the newly built facility, which is adjacent to Varsity Stadium, a site for the Football competition.

### > SPORT & VENUE SPECIFICATIONS

#### CURRENT STATUS

- New Build
- Construction Status: Completed by 2014
- Current/Future Owner: University of Toronto

#### VENUE HIGHLIGHTS

- Meets all International Federation specifications
- Seating Capacity: 2,000
- Distance from village: 5 minutes/6 km
- Parking spaces: over 3,000

#### CURRENT AND POST GAMES USE

- University of Toronto's Goldring Centre for High Performance Sport will create a space where researchers, graduate students, sport scientists, athletic therapists and coaches can converge to develop the latest techniques for taking Canada's top athletes to the next level.



### > COMPETITION SCHEDULE

JULY																		
Day	Thu	Fri	Sat	Sun	Mon	Tues	Wed	Thu	Fri	Sat	Sun	Mon	Tue	Wed	Thu	Fri	Sat	Sun
Date	9	10	11	12	13	14	15	16	17	18	19	20	21	22	23	24	25	26
Futsal													●	●	●	●	●	●

- Competition
- Finals (may include competitions on these days)

> COMPETITION SITE PLAN

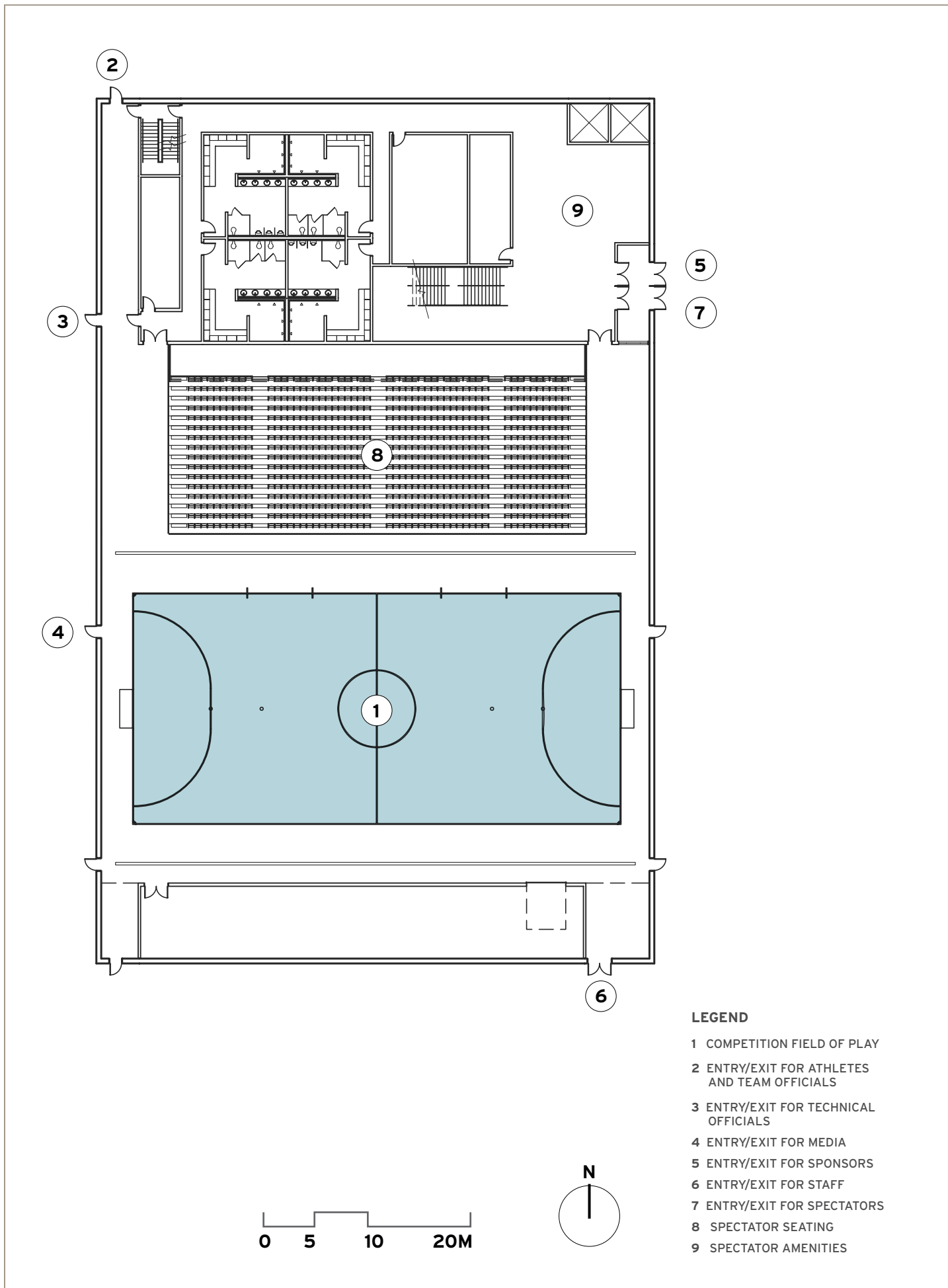

LEGEND

- 1 COMPETITION FIELD OF PLAY
- 2 ENTRY/EXIT FOR ATHLETES AND TEAM OFFICIALS
- 3 ENTRY/EXIT FOR TECHNICAL OFFICIALS
- 4 ENTRY/EXIT FOR MEDIA
- 5 ENTRY/EXIT FOR SPONSORS
- 6 ENTRY/EXIT FOR STAFF
- 7 ENTRY/EXIT FOR SPECTATORS
- 8 SPECTATOR SEATING
- 9 SPECTATOR AMENITIES



## SPORT: KARATE

### VENUE: Direct Energy Centre

With stunning design, the Direct Energy Centre is the focal point of Toronto's Exhibition Place, a lakefront complex that is a vibrant destination for public celebrations, festivals and events.

Magnificent in size and flexibility, the venue offers 100,000 m<sup>2</sup> of contiguous exhibit and event space, divisible into nine halls. Adapted for a number of sports, the Handball competition will be housed in this facility, which includes a significant cluster of sports for the Games, five minutes from the Pan American Village.

Sports competing at Exhibition Place also include Gymnastics, Beach Volleyball, Triathlon, Football, and Road Cycling.



### > SPORT & VENUE SPECIFICATIONS

#### CURRENT STATUS

- Existing
- Built in 1997
- Current/Future owner: City of Toronto

#### VENUE HIGHLIGHTS

- Meets all International Federation specifications
- Seating Capacity: 1,000
- Distance from village: 5 minutes/6 km
- Parking spaces: 7,400

#### CURRENT AND POST GAMES USE

- Exhibition Place is a mixed-use property on the Toronto shore of Lake Ontario, featuring expo, trade, and banquet centres, theater and music buildings, parkland, sports facilities, and a number of civic, provincial, and national historic sites.
- Hosting Experience:
  - 2003 Dalai Lama's Visit
  - 2002 Royal Visit / Queen Elizabeth II
  - 2002 World Youth Day / Pope John Paul II
  - Annual: Canadian National Exhibition (over 1 million annual visitors)



### > COMPETITION SCHEDULE

JULY																		
Day	Thu	Fri	Sat	Sun	Mon	Tues	Wed	Thu	Fri	Sat	Sun	Mon	Tue	Wed	Thu	Fri	Sat	Sun
Date	9	10	11	12	13	14	15	16	17	18	19	20	21	22	23	24	25	26
Karate			•	•	•													

- Finals (may include competitions on these days)

> COMPETITION SITE PLAN

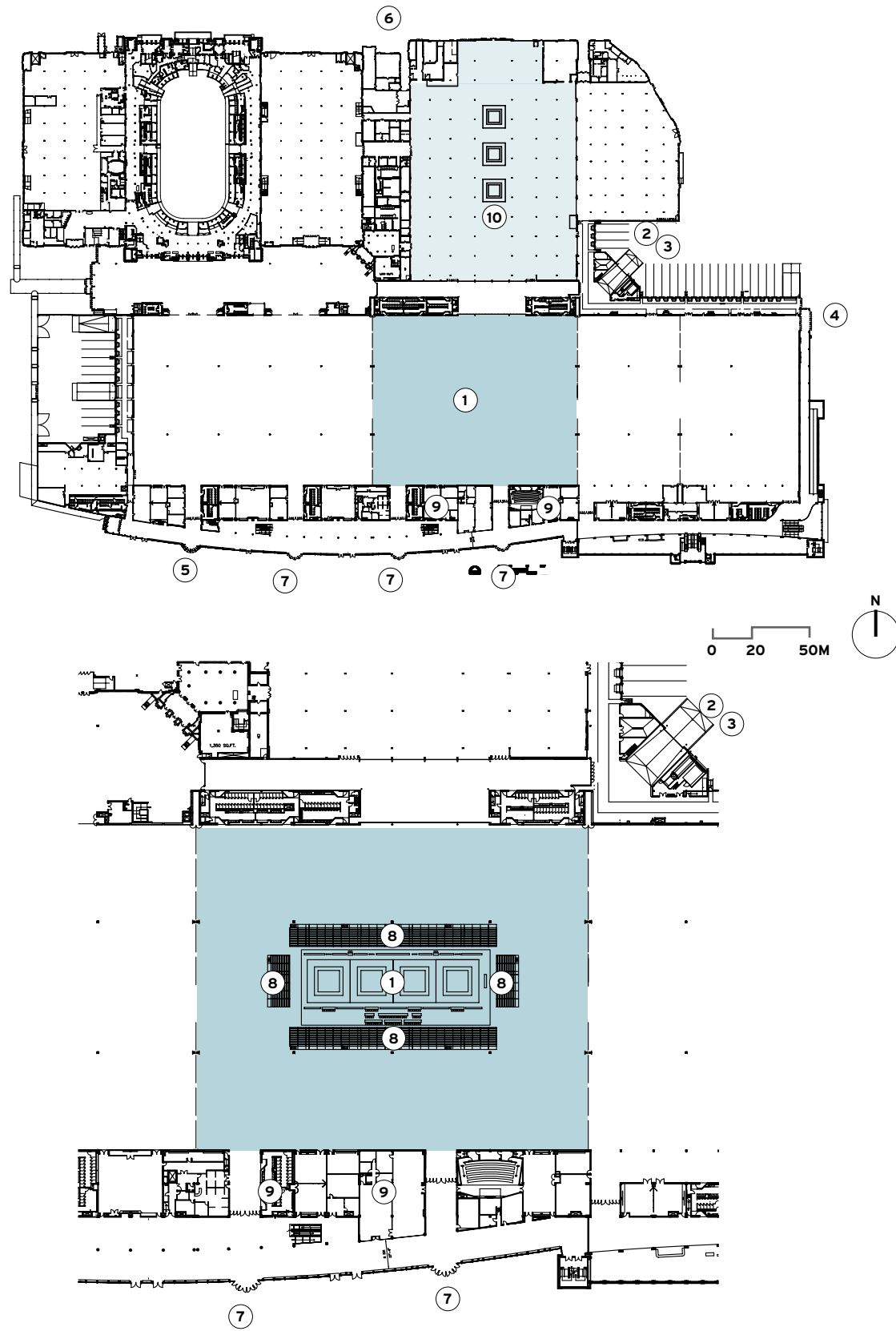

LEGEND

- |  |                             |
|--|-----------------------------|
| 1 COMPETITION FIELD OF PLAY                  | 7 ENTRY/EXIT FOR SPECTATORS |
| 2 ENTRY/EXIT FOR ATHLETES AND TEAM OFFICIALS | 8 SPECTATOR SEATING         |
| 3 ENTRY/EXIT FOR TECHNICAL OFFICIALS         | 9 SPECTATOR AMENITIES       |
| 4 ENTRY/EXIT FOR MEDIA                       | 10 WARM UP AREA             |
| 5 ENTRY/EXIT FOR SPONSORS                    |                             |
| 6 ENTRY/EXIT FOR STAFF                       |                             |

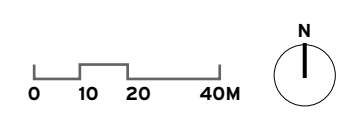



**SPORT:**  
**RACQUETBALL**

**VENUE: Ryerson University**

Racquetball will find its home in a planned new sport development at Ryerson University.

Located five minutes from the Pan American Village and in the heart of Toronto, this venue is in close proximity to other sport venues.



**> SPORT & VENUE SPECIFICATIONS**

CURRENT STATUS
<ul style="list-style-type: none"> <li>• Construction Status: Existing/Retrofit</li> <li>• Built in 1995</li> <li>• Current/Future Owner: Ryerson University</li> </ul>
VENUE HIGHLIGHTS
<ul style="list-style-type: none"> <li>• Meets all International Federation specifications</li> <li>• Seating Capacity: over 500</li> <li>• Distance from village: 5 minutes /6 km</li> <li>• Parking Spaces: 1,000</li> </ul>
CURRENT AND POST GAMES USE
<ul style="list-style-type: none"> <li>• This venue will be home to Ryerson University Inter-university athletics program, intramural sports program and community access for individual use.</li> </ul>



**> COMPETITION SCHEDULE**

JULY																		
Day	Thu	Fri	Sat	Sun	Mon	Tues	Wed	Thu	Fri	Sat	Sun	Mon	Tue	Wed	Thu	Fri	Sat	Sun
Date	9	10	11	12	13	14	15	16	17	18	19	20	21	22	23	24	25	26
Racquetball												●	●	●	●	●	●	●

● Competition ● Finals (may include competitions on these days)

> COMPETITION SITE PLAN

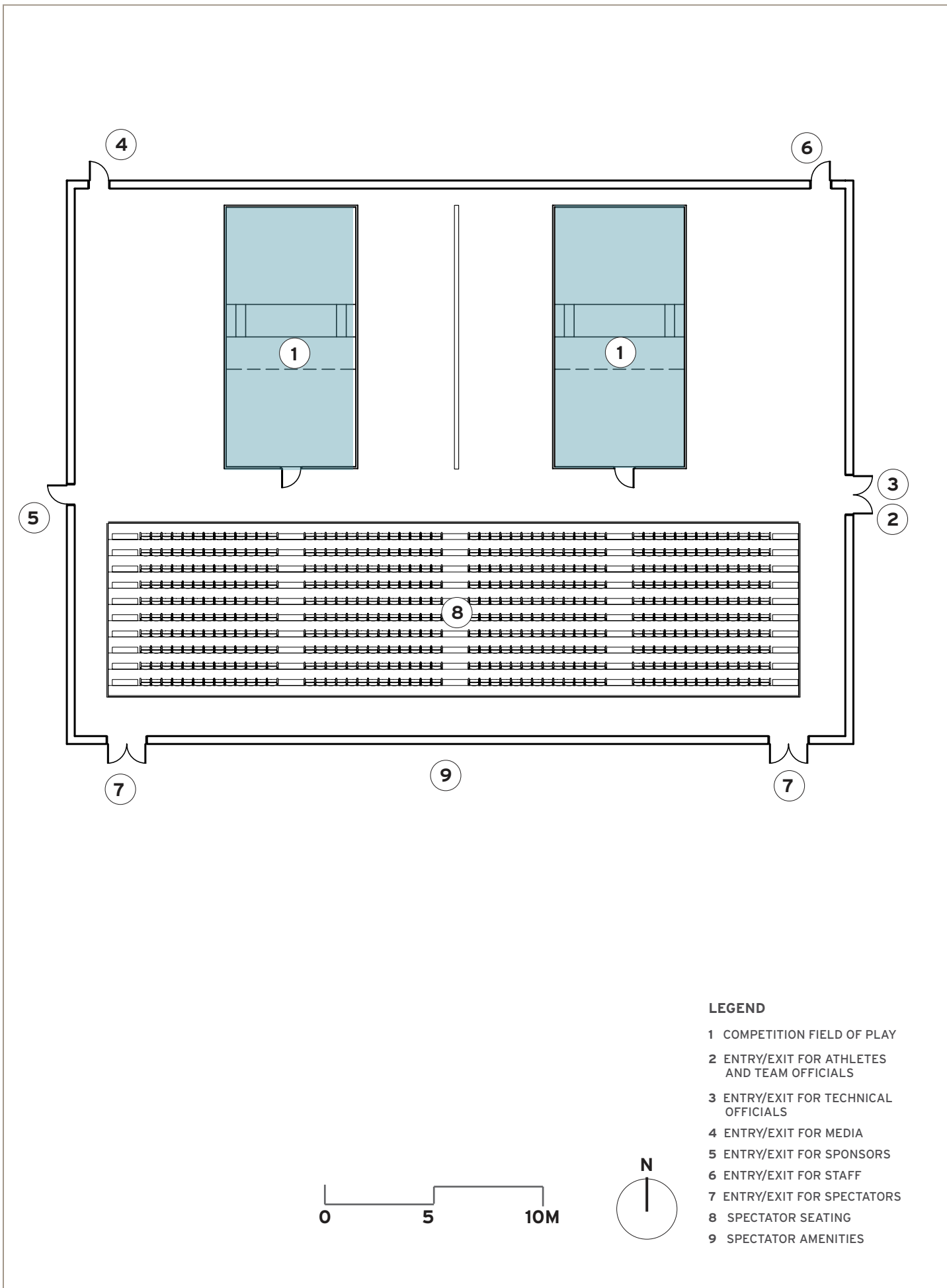

**LEGEND**

- 1 COMPETITION FIELD OF PLAY
- 2 ENTRY/EXIT FOR ATHLETES AND TEAM OFFICIALS
- 3 ENTRY/EXIT FOR TECHNICAL OFFICIALS
- 4 ENTRY/EXIT FOR MEDIA
- 5 ENTRY/EXIT FOR SPONSORS
- 6 ENTRY/EXIT FOR STAFF
- 7 ENTRY/EXIT FOR SPECTATORS
- 8 SPECTATOR SEATING
- 9 SPECTATOR AMENITIES



**SPORT:**  
**ROLLER SPORTS**

**VENUE: Iceland Mississauga**

Iceland Mississauga is a four arena complex, including an international size facility with 1,000 seats. This large facility provides a great venue with an adjacent warm up and training area for the artistic component and an outdoor venue for the track component.

As this site is adjacent to the Judo venue, it will create a cluster of sports making it easy for athletes and spectators to witness sport excellence at its best.



> **SPORT & VENUE SPECIFICATIONS**

**CURRENT STATUS**

- Existing
- Built in 1996
- Current/Future Owner: City of Mississauga

**VENUE HIGHLIGHTS**

- Meets all International Federation specifications
- Seating Capacity: 1000
- Distance from village: 27 minutes / 32 km
- Parking spaces: over 2,000

**CURRENT AND POST GAMES USE**

- Iceland Mississauga, a state-of-the-art, four pad ice complex, is situated on 160 acres of parkland. The parkland surrounding Iceland includes a Skateboard park, two artificial sports fields, walking trails, and picnic areas.



> **COMPETITION SCHEDULE**

JULY																		
Day	Thu	Fri	Sat	Sun	Mon	Tues	Wed	Thu	Fri	Sat	Sun	Mon	Tue	Wed	Thu	Fri	Sat	Sun
Date	9	10	11	12	13	14	15	16	17	18	19	20	21	22	23	24	25	26
Roller Sports Artistic												●	●	●				
Roller Sports Track															●	●	●	

- Finals (may include competitions on these days)

> COMPETITION SITE PLAN

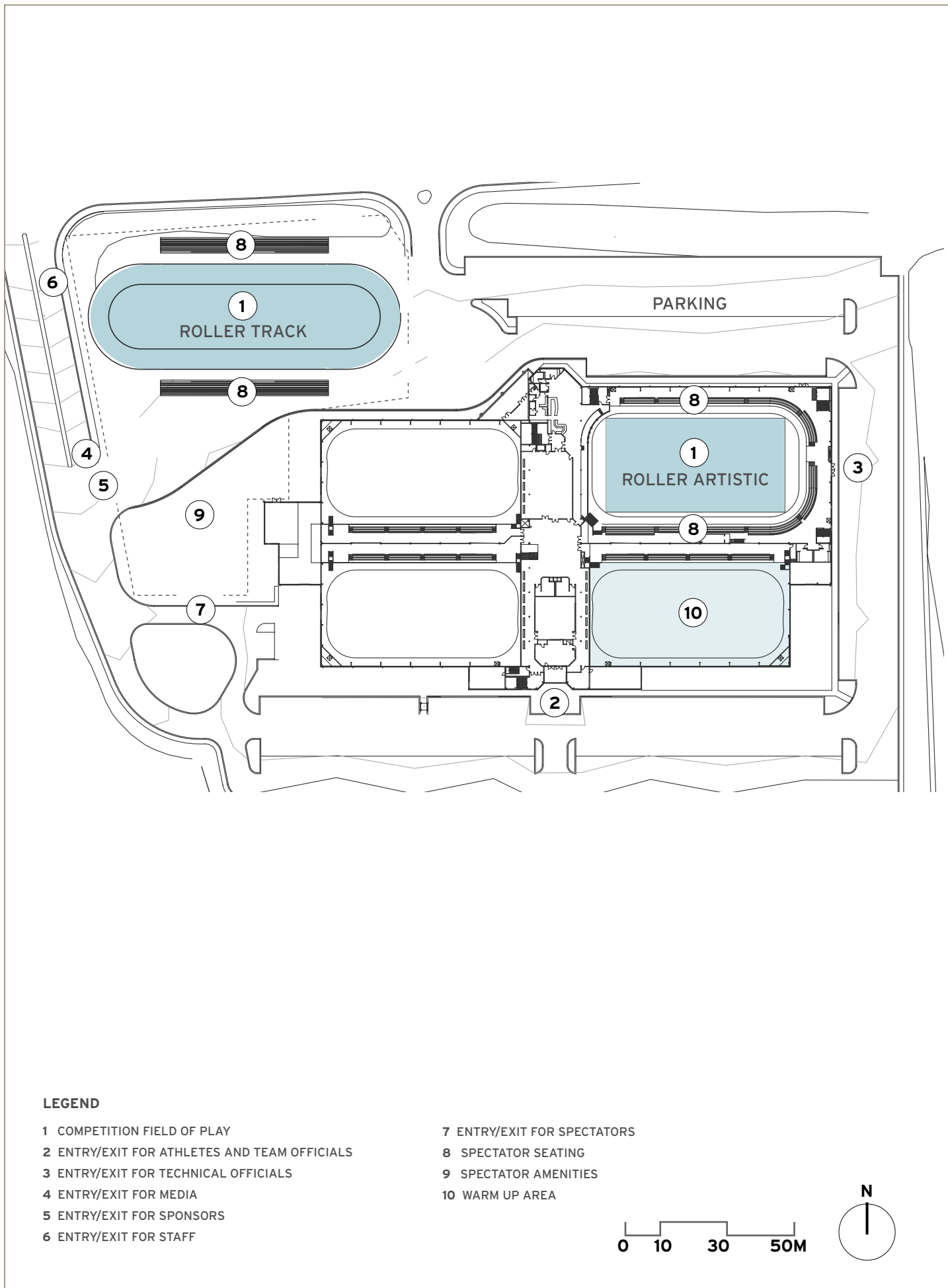

**LEGEND**

- |  |                             |
|--|-----------------------------|
| 1 COMPETITION FIELD OF PLAY                  | 7 ENTRY/EXIT FOR SPECTATORS |
| 2 ENTRY/EXIT FOR ATHLETES AND TEAM OFFICIALS | 8 SPECTATOR SEATING         |
| 3 ENTRY/EXIT FOR TECHNICAL OFFICIALS         | 9 SPECTATOR AMENITIES       |
| 4 ENTRY/EXIT FOR MEDIA                       | 10 WARM UP AREA             |
| 5 ENTRY/EXIT FOR SPONSORS                    |                             |
| 6 ENTRY/EXIT FOR STAFF                       |                             |

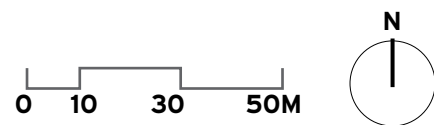



**SPORT:**  
**RUGBY SEVENS**

**VENUE:** Fletcher's Fields Rugby Park

Fletcher's Fields is one of Canada's major rugby centres. With its six fields, the Park has played host to major international matches, including the Churchill Cup featuring international teams such as Canada, England Saxons, Ireland A, Scotland A, the USA, and Argentinian XV.

With significant experience hosting international matches, this venue has solid footing and excellent sightlines to enhance the playing and viewing experience for all.



**> SPORT & VENUE SPECIFICATIONS**

**CURRENT STATUS**

- Existing
- Built in 1968
- Current/Future owner: Fletcher's Fields Rugby Park

**VENUE HIGHLIGHTS**

- Meets all International Federation specifications
- Seating Capacity: over 5,000
- Distance from village: 30 minutes / 29 km
- Parking spaces: over 1,000

**CURRENT AND POST GAMES USE**

- Fletcher's Fields is home to several competitive rugby clubs and is frequently used by Canada's national team. The fields are also used to host other local sport events such as football and lacrosse. Fletcher's Fields has hosted many international rugby games.
- Hosting Experience:
  - 2003 - 2009 Churchill Cup
  - Numerous International Matches



**> COMPETITION SCHEDULE**

JULY																		
Day	Thu	Fri	Sat	Sun	Mon	Tues	Wed	Thu	Fri	Sat	Sun	Mon	Tue	Wed	Thu	Fri	Sat	Sun
Date	9	10	11	12	13	14	15	16	17	18	19	20	21	22	23	24	25	26
Rugby (W)														●	●			
Rugby (M)																●	●	

- Competition
- Finals (may include competitions on these days)

> COMPETITION SITE PLAN

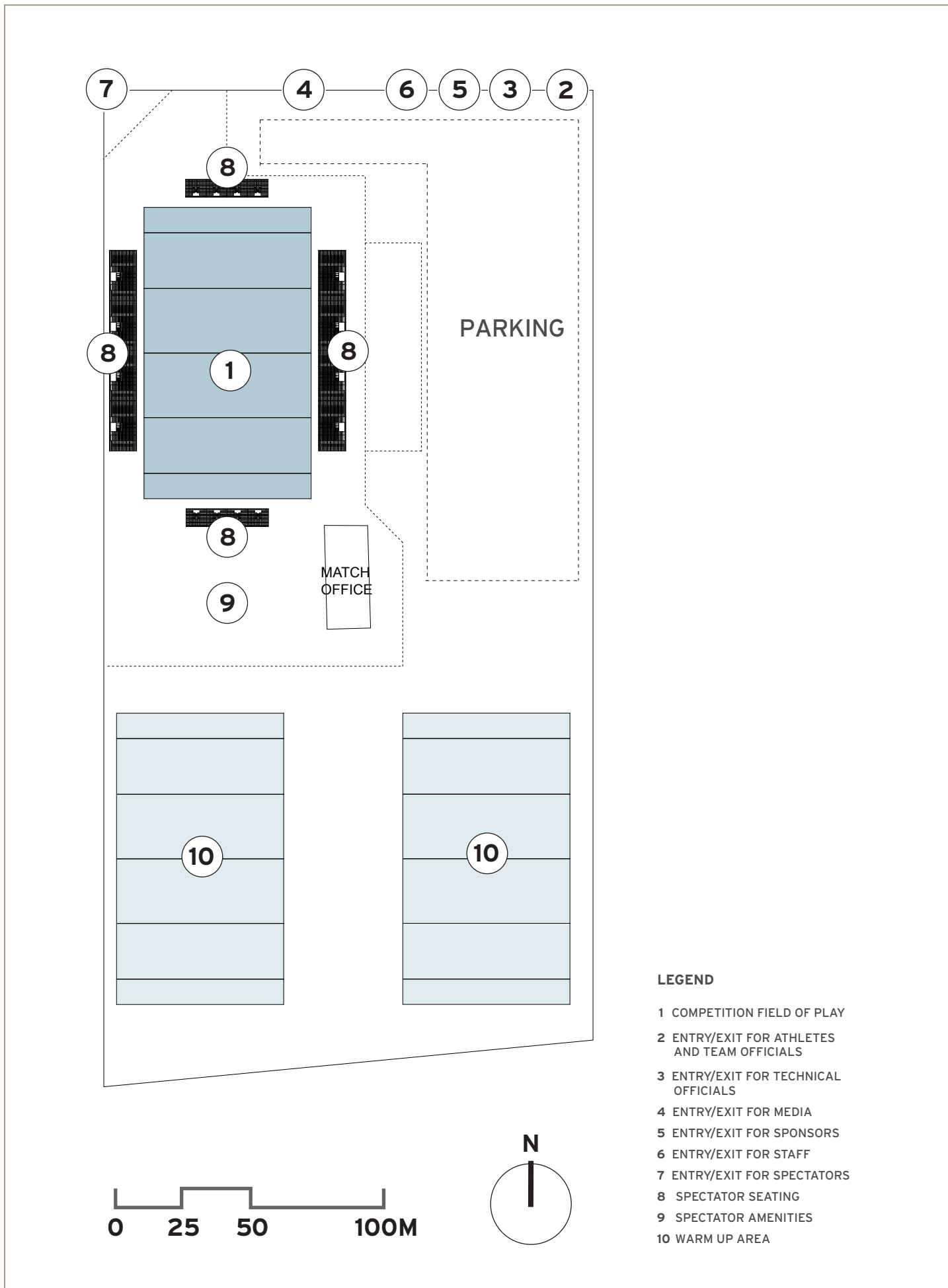

**LEGEND**

- 1 COMPETITION FIELD OF PLAY
- 2 ENTRY/EXIT FOR ATHLETES AND TEAM OFFICIALS
- 3 ENTRY/EXIT FOR TECHNICAL OFFICIALS
- 4 ENTRY/EXIT FOR MEDIA
- 5 ENTRY/EXIT FOR SPONSORS
- 6 ENTRY/EXIT FOR STAFF
- 7 ENTRY/EXIT FOR SPECTATORS
- 8 SPECTATOR SEATING
- 9 SPECTATOR AMENITIES
- 10 WARM UP AREA





## SPORT: SOFTBALL

### VENUE: Lakefront West Park

Lakefront West Park is one of the region's newest and largest multi-diamond facilities. With eight lighted fields on the shores of Lake Ontario, and nestled in Lynde Shore Conservation area, this venue will include a 10,000 seat main stadium providing a large venue to accommodate this popular sport.

With a number of sports clustered in the area, such as Boxing, spectators and participants will have substantial opportunities to enjoy a variety of sports in a compact region.



### > SPORT & VENUE SPECIFICATIONS

#### CURRENT STATUS

- Existing
- Built in 1995
- Current/Future Owner: City of Oshawa

#### VENUE HIGHLIGHTS

- Meets all International Federation specifications
- Seating Capacity: 10,000
- Distance from village: 40 minutes / 59 km
- Parking spaces: over 2,500

#### CURRENT AND POST GAMES USE

- In addition to multiple community and competitive leagues, its large number of diamonds makes it a perfect tournament facility for provincial, national and international events.



### > COMPETITION SCHEDULE

JULY																		
Day	Thu	Fri	Sat	Sun	Mon	Tues	Wed	Thu	Fri	Sat	Sun	Mon	Tue	Wed	Thu	Fri	Sat	Sun
Date	9	10	11	12	13	14	15	16	17	18	19	20	21	22	23	24	25	26
Softball												●	●	●	●	●	●	

- Competition
- Finals (may include competitions on these days)

> COMPETITION SITE PLAN

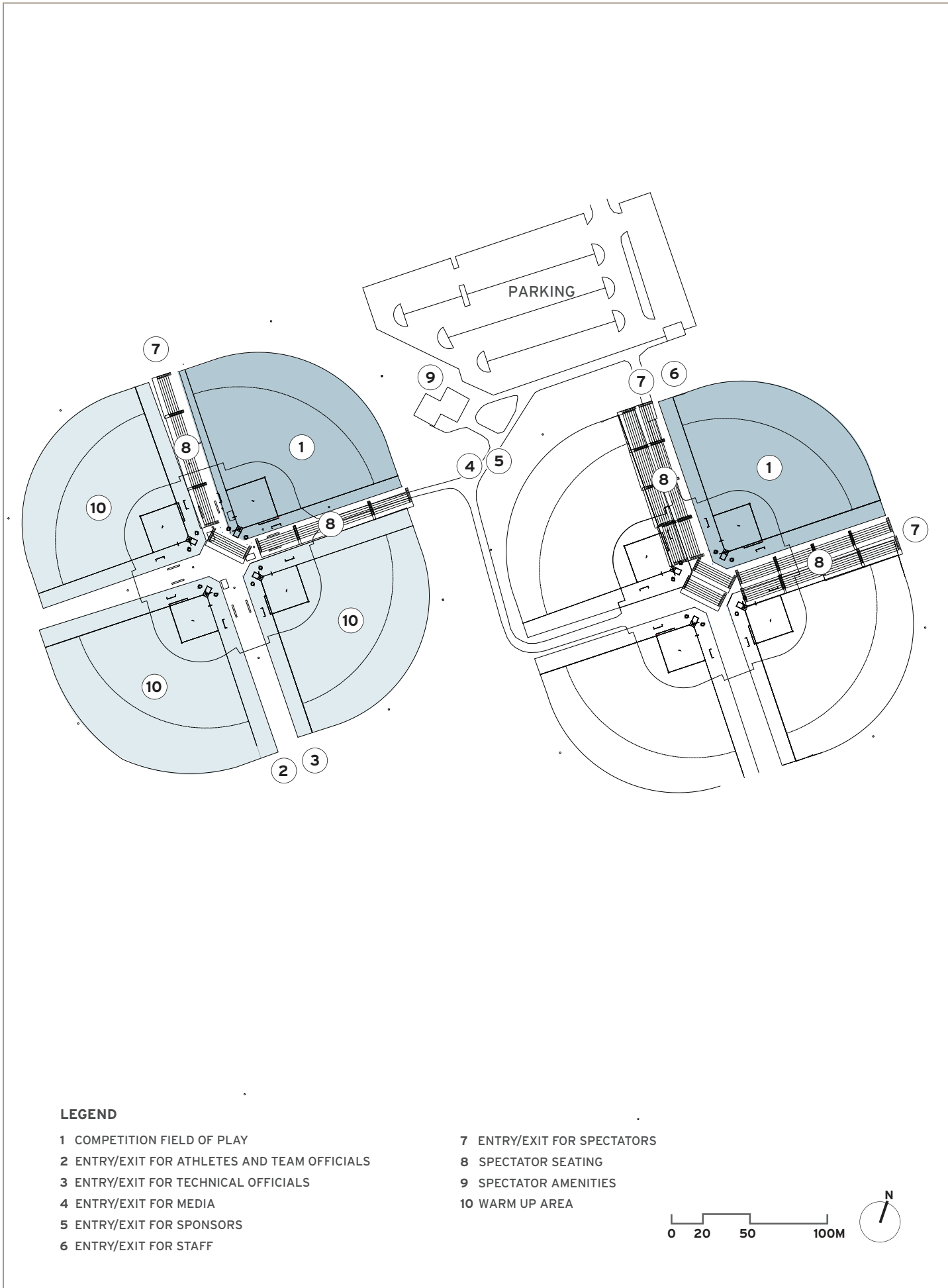

**LEGEND**

- |  |                             |
|--|-----------------------------|
| 1 COMPETITION FIELD OF PLAY                  | 7 ENTRY/EXIT FOR SPECTATORS |
| 2 ENTRY/EXIT FOR ATHLETES AND TEAM OFFICIALS | 8 SPECTATOR SEATING         |
| 3 ENTRY/EXIT FOR TECHNICAL OFFICIALS         | 9 SPECTATOR AMENITIES       |
| 4 ENTRY/EXIT FOR MEDIA                       | 10 WARM UP AREA             |
| 5 ENTRY/EXIT FOR SPONSORS                    |                             |
| 6 ENTRY/EXIT FOR STAFF                       |                             |

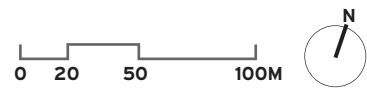



**SPORT:**  
**SQUASH**

**VENUE:** Metro Toronto Convention Centre

All squash events will be take place at the Metro Toronto Convention Centre with the main stadium court located at the John Bassett Centre. This 1,330 seat, multi-purpose theatre is a self-contained venue within the North Building of the Metro Toronto Convention Centre, which has hosted the Canadian Squash Championships.

The adjacent Hall B will house a second stadium court with 1,000 seats and four additional squash courts, minutes from the Pan American Village and in the same complex as the Media Centre.



> **SPORT & VENUE SPECIFICATIONS**

CURRENT STATUS
<ul style="list-style-type: none"> <li>Existing</li> <li>Built in 1984</li> <li>Current/Future Owner: Province of Ontario</li> </ul>
VENUE HIGHLIGHTS
<ul style="list-style-type: none"> <li>Meets all International Federation specifications</li> <li>Seating Capacity: 1,300</li> <li>Distance from village: 5 minutes / 3 km</li> <li>Parking spaces: 1,700</li> </ul>
CURRENT AND POST GAMES USE
<ul style="list-style-type: none"> <li>With its stepped seating, balcony and state-of-the-art features, the John Bassett Theatre has been the venue of choice for many corporate events, a number of nationally-televised award shows, community events and countless national and international TV specials.</li> <li>Hosting Experience:               <ul style="list-style-type: none"> <li>2007 &amp; 2008 Pace Canadian Squash Classic</li> </ul> </li> </ul>



> **COMPETITION SCHEDULE**

JULY																		
Day	Thu	Fri	Sat	Sun	Mon	Tues	Wed	Thu	Fri	Sat	Sun	Mon	Tue	Wed	Thu	Fri	Sat	Sun
Date	9	10	11	12	13	14	15	16	17	18	19	20	21	22	23	24	25	26
Squash											●	●	●	●	●	●	●	●

● Competition    ● Finals (may include competitions on these days)

> COMPETITION SITE PLAN

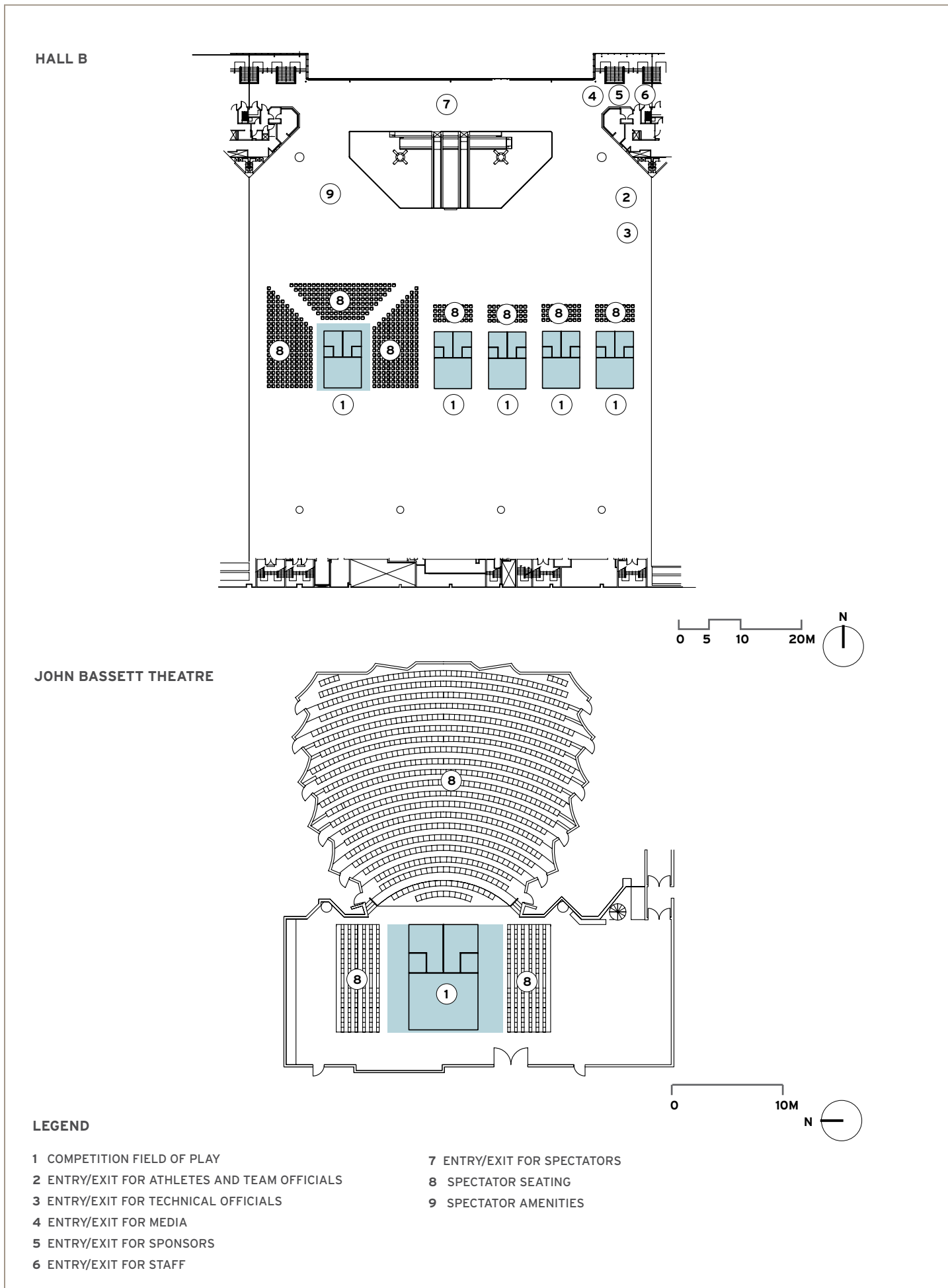



**SPORT:**  
**WATER SKI/  
WAKEBOARD**

**VENUE: Long Pond - Toronto Island**

Long Pond, on Toronto Island offers a fully protected water course with a perfect width and length for water skiing and wakeboarding. The shoreline on both sides of the course is sloped to minimize wake rebound. As a spectator venue, the Long Pond site provides unobstructed viewing for the entire length of the course and has an existing grandstand already in place.

Combining its previous experience as a venue for major sport events and a fantastic view of the City of Toronto landscape, this one of a kind site will deliver some of the most exciting moments of the Games.

**> SPORT & VENUE SPECIFICATIONS**

CURRENT STATUS
<ul style="list-style-type: none"> <li>Existing</li> <li>Current/Future Owner: City of Toronto</li> </ul>
VENUE HIGHLIGHTS
<ul style="list-style-type: none"> <li>Meets all International Federation specifications</li> <li>Seating Capacity: 5,000</li> <li>Distance from village: 15 minutes /1 km</li> <li>Parking spaces: Ferry Service to Competition Site</li> </ul>
CURRENT AND POST GAMES USE
<ul style="list-style-type: none"> <li>Long Pond was specifically designed as a watersports course and has a long history of hosting international water skiing, wakeboarding and rowing events.</li> <li>Hosting Experience:               <ul style="list-style-type: none"> <li>2009 Toronto International Dragon Boat Race Festival</li> <li>2005 - 2008 Wakestock Festival; World Wakestock Association World Series of Wakeboarding</li> <li>1979 - World Water Ski Championships</li> </ul> </li> </ul>



**> COMPETITION SCHEDULE**

JULY																		
Day	Thu	Fri	Sat	Sun	Mon	Tues	Wed	Thu	Fri	Sat	Sun	Mon	Tue	Wed	Thu	Fri	Sat	Sun
Date	9	10	11	12	13	14	15	16	17	18	19	20	21	22	23	24	25	26
Water Ski/Wakeboard															●	●	●	●

● Competition    ● Finals (may include competitions on these days)

> COMPETITION SITE PLAN

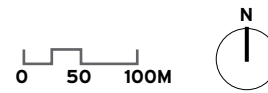
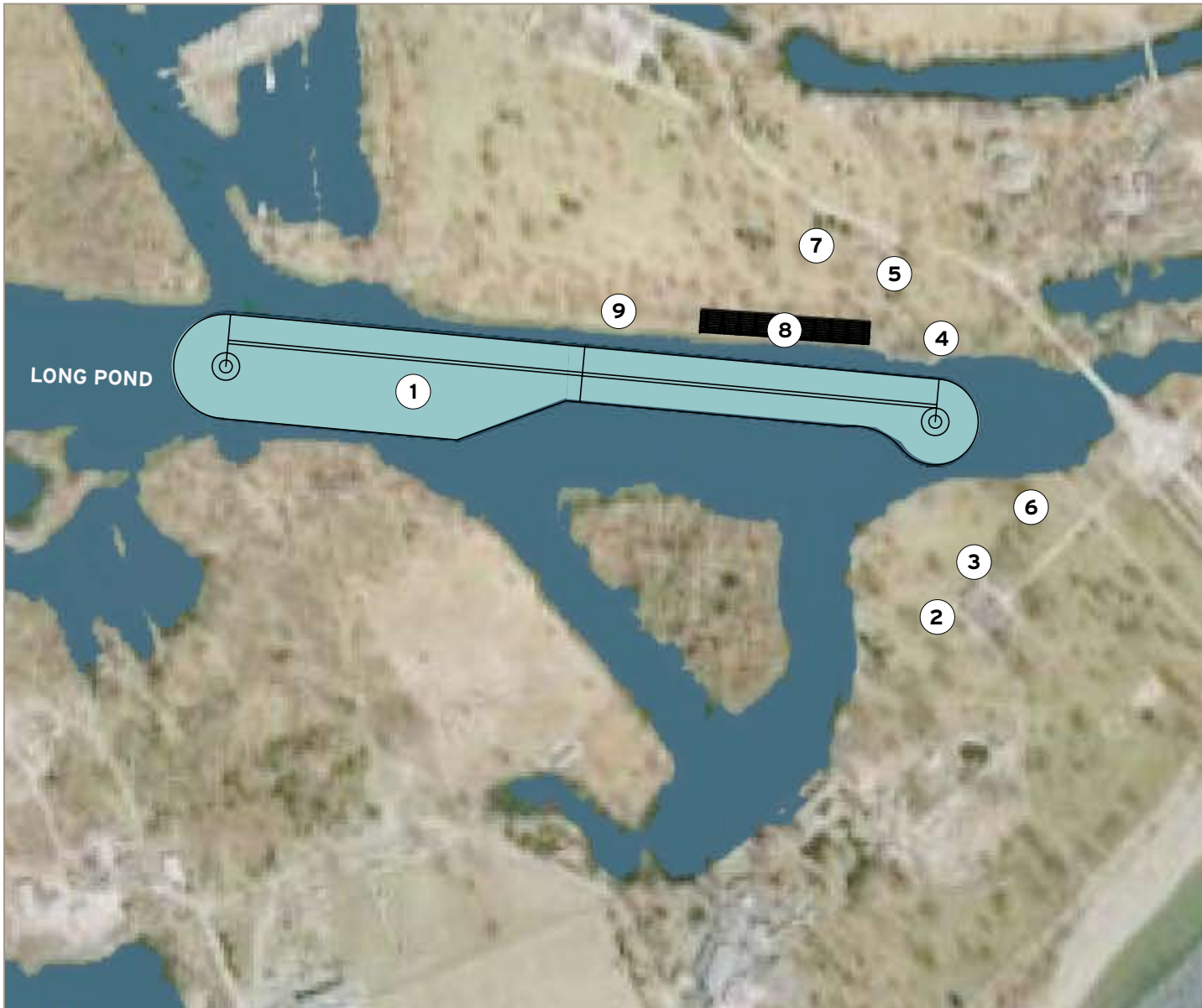

**LEGEND**

- 1 COMPETITION FIELD OF PLAY
- 2 ENTRY/EXIT FOR ATHLETES AND TEAM OFFICIALS
- 3 ENTRY/EXIT FOR TECHNICAL OFFICIALS
- 4 ENTRY/EXIT FOR MEDIA
- 5 ENTRY/EXIT FOR SPONSORS
- 6 ENTRY/EXIT FOR STAFF
- 7 ENTRY/EXIT FOR SPECTATORS
- 8 SPECTATOR SEATING
- 9 SPECTATOR AMENITIES

## **SECTION HIGHLIGHTS:**

Beginning a year before the Games, the Toronto 2015 cultural festival will showcase artists and performers from throughout the Western Hemisphere. The festival will peak with the athlete-friendly Opening and Closing Ceremonies staged in the comfort of a 46,000-seat, retractable-roof stadium with the indoor athlete marshalling area just steps away. The Games' cultural program will break new ground by celebrating innovation in sport, technology, social enterprise, education and business.





# CEREMONIES, CULTURE AND INNOVATION

## THE IMPACT OF CULTURAL ENTERPRISE ON TORONTO

- The cultural sector in Toronto employs more than 133,000 people and generates approximately \$9 billion annually
- Employment in the creative sector is growing by 2.1% annually, compared with 1.8% growth in the financial services sector
- In 2006, more than 11.5 million people attended almost 25,000 arts and cultural events funded by the City of Toronto

edented investment in cultural infrastructure. The Royal Ontario Museum, Art Gallery of Ontario, Royal Conservatory of Music, National Ballet School, Gardiner Museum and Ontario College of Art and Design are all world-class institutions that have recently benefited from major renovations and expansions – in each case designed by world-renowned architects – to their respective facilities.

The Toronto International Film Festival continues to cement its reputation as the largest and arguably most influential film festival in the world. Toronto's rich festival schedule also includes traditional successes like the Canadian Aboriginal Festival, along with newer additions like the Scotiabank Nuit Blanche Toronto and Luminato, a major new international festival.

## OPENING CEREMONY

The Opening Ceremony will take place on July 10, 2015 at the Rogers Centre, the world's first stadium with a fully-retractable roof. The Stadium seats 46,000 and is equipped with state-of-the-art production, broadcast

and web-based technology. The retractable roof ensures that weather will not adversely affect the ceremony or the athletes. In fact, with the athletes marshalling in the Metro Toronto Convention Centre (MTCC), 600m from the floor of the Rogers Centre, the athletes will be in climate-controlled, comfortable and secure environments for the entirety of their time preparing for and participating in the Opening Ceremony. The short distance between the MTCC and Rogers Centre can be enclosed by a canopy for protection in the unlikely event of wet weather or for added security.

As part of Toronto 2015's overall athlete-centred approach to the Games, both the Opening Ceremony and the Closing Ceremony will be distinctly athlete-friendly.

## CEREMONIES: TAKING CARE OF THE ATHLETES

- Marshalling area for ceremonies is 600 m from the Rogers Centre
- Fully climate-controlled environment with seating
- Access to washrooms and refreshments
- Closed-circuit feed of live ceremonies for athletes in marshalling area
- Strict adherence to PASO regulations regarding length of ceremonies

Teams will marshal in climate-controlled comfort with ample seating, an appropriate number of washrooms, complimentary refreshments and closed-circuit monitors showing the live proceedings of the ceremonies.

The ceremonies will follow PASO regulations, including the full engagement of the PASO Chancellor, PASO Executive Committee, Technical Commission and NOC members in the planning. The ceremonies will reflect all PASO protocol and cultural regulations including English and Spanish communication, transportation time for the athletes, access routes, security and a commitment to meeting the time allocation prescribed. Detailed plans for the Opening Ceremony and the Closing Ceremony will be shared with the PASO Executive Committee one year in advance of the Games.

### PAN AMERICAN FLAME

The Pan American flame is an important, symbolic and moving element of the Games and, in particular, of the Opening Ceremony. Section XV of the Pan American Regulation describes the procedure for the entry of the flame into the stadium and the lighting of the flame cauldron. One of the most distinctive elements of that procedure is the acknowledgment by the flame bearer of the four car-

dinal points – north, south, east and west. While the exact details of the ceremony are understandably still to be confirmed, Toronto 2015 plans to extend this elegant aspect of the ceremony by bringing four smaller Pan American flame torches to the Games from the four cardinal points of the Province of Ontario, thereby involving the entire province, building excitement and anticipation for the Games and focusing specifically on involving children and youth in the torch relays. At the Opening Ceremony, the four smaller torches will unite to light the single torch that will ignite the Pan American flame cauldron.

As Athletics will not take place at the Rogers Centre, an additional flame cauldron will be established at the Athletics Stadium, as prescribed by PASO regulations. Following the conclusion of the Opening Ceremony, the Pan American flame will be transferred to the Athletics Stadium and later returned to Rogers Centre for the Closing Ceremony.

### CLOSING CEREMONY

The Closing Ceremony will also take place in the controlled comfort of the Rogers Centre with a similarly comfortable marshalling plan for the athletes. The ceremony will celebrate the performances of the athletes, the accomplishments of PASO and the multicultural character of both the host city and the nations in the PASO family.

The Closing Ceremony will follow all applicable PASO regulations.

### AWARD CEREMONIES AT INDIVIDUAL VENUES

All medal award ceremonies will take place at the applicable sport venues after each competition and will be conducted in accordance with the guidelines of PASO and the respective International Sport Federations and under the overall supervision and control of the PASO Executive Committee.



↑ TORONTO BLUE JAYS AT ROGERS CENTRE  
PHOTO CREDIT: TOURISM TORONTO



↑ NEW YEAR'S EVE CELEBRATION AT NATHAN PHILLIPS SQUARE

## VICTORY CELEBRATIONS

Victory celebrations will be held daily at Nathan Phillips Square – Toronto's civic square situated on the grounds of the futuristic Toronto City Hall. Nathan Phillips Square is a well-tested event venue, regularly hosting concerts and exhibitions as well as the annual Cavalcade of Lights holiday festivities and the city's annual New Year's Eve celebration.

The victory celebrations will be an opportunity to recognize the medalists in the evening when even greater numbers of people will be able to celebrate the athletes' achievements. This will open the Games to all area residents and provide additional broadcast and media opportunities. Different programs will be designed for each day to include music and cultural entertainment.

## TORONTO 2015 CULTURAL FESTIVAL

Toronto 2015 will coordinate and sponsor a Pan American cultural festival that will begin in the years before the Games and continue through to the conclusion of the 2015 Games. This celebration will help build the brand and awareness of the Pan American Games as well as encourage Canada's arts and cultural organizations to seek out and form partnerships with organizations in other Pan American countries. Through an exchange of art, culture and sport throughout the Americas and the Caribbean, the festival will emphasize the

connections among Pan American peoples and nations, with a special emphasis on both Aboriginal cultures and the countries that have hosted previous Pan American Games. This approach will simultaneously link nationalities and ethnicities while enhancing the profile of PASO and the Pan American Games movement.

During the Games, the cultural festival will create a constant sense of the Games atmosphere, even away from the sport venues. The vast majority of festival events, performances and installations will be free to attendees to ensure that the widest possible range of people are able to participate.

## COUNTDOWN CELEBRATION

In addition to hosting test events at new and renovated sport venues, Toronto 2015 will host a number of public celebrations and cultural events throughout the city and more widely in Ontario as part of an informal countdown to the start of the Games. These events will feature athlete and mascot appearances and cultural elements, along with opportunities to enhance the marketing of the Games through on-site ticket sales, volunteer recruitment and merchandise sales.

## YOUTH FESTIVAL

Youth engagement programs are among the many hallmarks of the work PASO supports throughout the Western Hemisphere. The Youth Festival will be a critical element of the cultural program of Toronto 2015. Contemplating initiatives related to youth volunteering, employment and leadership, the Toronto 2015 Pan American Youth Festival will take the spirit of youth engagement into communities across the Toronto region in the pre-Games period. Promoting the ideals of diversity, collaboration and healthy, active living, the Youth Festival will organize concerts, neighbourhood interactive exhibitions (for example, of the sports of the Pan American Games) and virtual networks designed to attract and interest the widest variety of youth. The festival will engage youth in the Pan American Games



CANADIAN ABORIGINAL FESTIVAL  
PHOTO CREDIT: TOURISM TORONTO

and provide them with opportunities for personal growth and development.

### **FESTIVAL OF CULTURE AND SPORT**

The Pan American Games celebrate sport and culture, uniting the diverse nations of PASO in the shared passion for friendly competition and the pursuit of excellence in sport. Of course, not all sports are part of the Pan American Games Sport Program and many of Toronto's diverse communities have strong ties to particular sports that are not part of the Pan American Games tradition. In an effort to engage the full tapestry of Toronto's diverse community and to interest new fans in the Pan American Games, Toronto 2015 will sponsor a selection of sport festivals for non-Pan American sports. Likely examples of festival sports include cricket and lacrosse, Canada's national sport. Toronto 2015 will consult with the region's diverse communities and sport leaders to identify additional festival partners.

### **EDUCATIONAL PROGRAM**

Toronto 2015 will build on the Canadian Olympic Committee's landmark Canadian Olympic School Program in partnership with local, provincial and select national schools. This multilingual initiative engages both teachers and students in values-based education for Grades 2 through 12. The program will provide resources and encourage Canadian children and youth to learn more about the nations and cultures of the Americas and the Caribbean. While the Pan American Games will be the platform for this program, the content of the educational modules will go far beyond sport to include geography, history, politics and culture.

### **COLLABORATIVE INNOVATION**

The heart of the Pan American Games, indeed of any international multi-sport games, is and always will be sport. Increasingly, however, the cultural program is being recognized as an integral element of most games. Toronto 2015 will expand the cultural program to include a number of other facets that will be united by the concept of "collaborative innovation."

An open and informed exchange of ideas and a shared sense of responsibility for solving problems and sparking progress hold the most hope

for initiating real change, for creating prosperity, for enriching lives, and for fostering equality, stability and inclusion. Toronto 2015 will strive to encourage this process by incorporating programming along three themes:

- Innovation in Sport and Life Sciences
- Innovation in Technology and Entrepreneurship
- Innovation in Social Justice and Sustainability

In each case, Toronto 2015 will partner with leading Canadian organizations, from businesses to universities and from hospitals to social service organizations, to lead a number of initiatives that reach out to the nations of the Western Hemisphere, inviting experts to engage in the Toronto 2015 collaborative innovation program, to share ideas and best practices and to help push forward the leading edge of progress with the ultimate goals of benefiting the individuals, communities and countries of the Americas and the Caribbean.

The specific program will evolve as Toronto 2015 engages in its own process of collaborative innovation with local and international partners, but the strategy will begin with a number of initial projects.

## INNOVATION IN SPORT AND LIFE SCIENCES

**Sport and Wellness Innovation Symposium:** During the 2015 Games, the Sport and Wellness Innovation Symposium will encourage collaboration among PASO nations and NOC's by inviting sport and wellness leaders from the Americas and the Caribbean to join with Canada's innovators in presentations and dialogue. The symposium will work closely with the media relations office of Toronto 2015 to ensure that examples, findings and innovations from the symposium are available to complement and enrich the daily coverage of the Games competition.

**Technology and Healthy Aging Symposium:** The focus of programs around sport and healthy activity is usually on children and youth, but with aging populations around the world, the activity levels of older adults is becoming increasingly important. Technology can help prolong brain and physical fitness and improve quality of life. This symposium will showcase a

variety of new technologies from games to computer-assisted devices to help connect this important demographic group to the legacy and impact of the 2015 Pan American Games.

Both the Sport and Wellness Innovation Symposium and the Technology and Healthy Aging Symposium will take place at MaRS, Toronto's hub for innovation and collaboration across the disciplines of science, business and finance.

## INNOVATION IN TECHNOLOGY AND ENTREPRENEURSHIP

**Youth Science Fair:** Toronto will host a Pan American youth science fair designed to attract and encourage the brightest minds to use science to solve social challenges and/or create economic opportunity.

**Virtual Think Tank:** Toronto 2015 will sponsor a series of online conferences for innovative thinkers on a variety of subjects. The goal will be to bring the latest technological breakthroughs to a group of leaders who will be able to envision and even accelerate the application of technology to the problems and opportunities of the day.

## INNOVATION IN SOCIAL JUSTICE AND SUSTAINABILITY

**Mayors' Conference:** Toronto 2015 will facilitate a conference for Mayors from throughout PASO to discuss the best practices and innovative strategies for addressing the most pressing urban issues of the Western Hemisphere.

**Making Change, Leaders in Social Innovation:** In the cultural elements of the Toronto 2015 Games, from the Opening Ceremony to the musical performances and the Games website, leaders in creating social change – the innovators whose work tackles hunger, disease, poverty and disability, whose efforts protect cultures, knowledge or the environment – will be part of the program. Videos, displays, information and even appearances by social innovators from throughout the Western Hemisphere will be integrated into the Games cultural program.

**Youth Difference Makers' Conference:** Toronto will host youth from throughout the Americas and Caribbean who have made a difference in their home communities through volunteering, leadership and innovation. The conference will encourage them to share innovative ideas and powerful resources in order to advance their work and create new social innovations.

## SECTION HIGHLIGHTS:

Toronto 2015's innovative media plan begins by working with Guadalajara 2011 to ensure that the 2011 Pan American Games have a significant broadcast presence in Canada. Then in 2015, Toronto's aggressive approach to utilizing new media will connect more people to the Games in more ways than ever before. Toronto is a global media capital with strong infrastructure and significant multi-sport games broadcast experience. The city also offers large media clusters in both sport and multicultural programming.



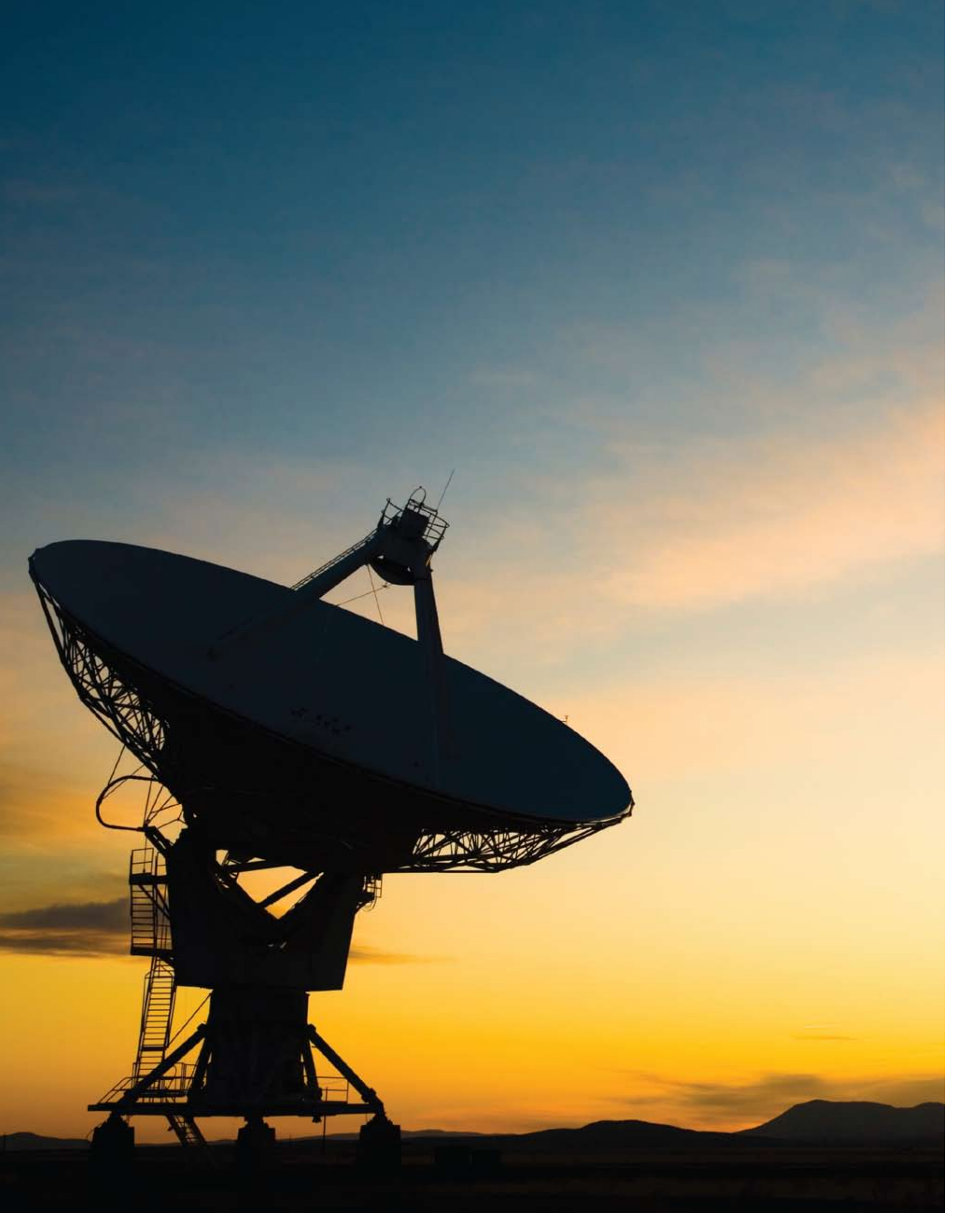

# MEDIA FACILITIES AND SERVICES

## EXTENSIVE EXPERIENCE

Canada's media industry has extensive experience working at the highest level both domestically and with international partners to deliver outstanding results in sport broadcast, print and new media. Toronto is the media centre of the country, with exceptional infrastructure in terms of talent, technology and equipment. Toronto 2015 is ready to help media partners throughout the Americas and Caribbean tell the story of the Pan American Games.

Toronto boasts three major national television networks; six major daily newspapers (two with national readership); four general all-sports television networks; seven specialty sport networks covering everything from basketball to motorsports, and combative sports to international sports coverage; and one of the first all-sports radio stations in the world.

Canada has a proud tradition of hosting international sporting events and providing world-class television feeds for events such as the 1988 Olympic Winter Games in Calgary, the 1999 Pan American Games in Winnipeg, the 2007 FIFA Under-20 World Cup and the upcoming 2010 Olympic and Paralympic Winter Games in Vancouver.

## CANADA'S MULTICULTURAL MEDIA

Canada's multicultural society is reflected in its media resources. The country offers more than 250 ethnicity-, nationality- or language-specific newspapers, representing more than 40 cultures, including 7 non-English dailies. Several Spanish-language print and online media outlets, including the daily *El Popular*, Canada's national Hispanic newspaper, are based in Toronto. Ethnic television is flourishing. Canada's first multicultural television station is based in Toronto and broadcasts programming in 22 languages. Seven more ethnic specialty and pay-television services, and 44 digital specialty services, have been licensed across the country.

Canada has 14 full-service radio stations providing programming for different multicultural groups. More than 60 mainstream radio stations include ethnic programming in their schedules.

### A MEDIA AND MARKETING PLAN THAT BEGINS IN 2011

To help drive excitement in Canada for the 2015 Pan American Games, to build the Pan American brand and to increase exposure for 2015 partners, advertisers and sponsors, Toronto 2015 is committed to working with Guadalajara 2011 to provide up to 50 hours of broadcast coverage of the 2011 Games in Canada.

## A VISIONARY BROADCAST PLAN

Toronto 2015 is committed to telling the story of the Games throughout Canada, the Caribbean and the Americas. That commitment will begin with the 2011 Games when Toronto 2015 will work with Guadalajara to provide up to 50 hours of coverage of the 2011 Games in Canada. This will grow to more than 300 hours in English, Spanish and French for the 2015 Games.

Toronto 2015 is also committed to leveraging Toronto's proximity to the United States and Toronto's outstanding media services to make every effort to bring coverage of

the 2015 Games to the vast United States market and to reach the international television audience through daily highlight packages.



## EMERGING MEDIA

As much as television is the dominant medium in the sport world of 2009, internet-based media are rapidly revolutionizing the coverage of sports. By 2015, the balance will likely have swung decidedly toward new media and Toronto 2015 will be ready to capitalize on the latest developments in media technology.

It is premature to speculate on the exact trends and new technologies of 2015, but Toronto 2015 will assemble a technology plan and team that will be adaptable and capable of accommodating the technological advances of the next six years. Part of the evaluation of new technology will be its reliability. The 2015 Games will employ only proven technology to deliver the results and stories of the Games.

Toronto 2015 will ensure that the widest range of users, from the traditional main-stream media to the average fan, regardless of physical location, will have access to the most accurate, complete and up-to-date information possible through the most convenient delivery vehicle. These strategies must, however, maintain the integrity of the Games' responsibilities to its broadcast partners.

## MEDIA CENTRE

The Media Centre (MC) will include both the Main Press Centre (MPC) and the International Broadcast Centre (IBC). It will be located in the heart of downtown Toronto at the Metro Toronto Convention Centre (MTCC) and will be the most important venue for the work of the more than 1,500 media personnel from television (including the host broadcaster), web-based media, radio and print media.

Media will have instant access to results and information about events and athletes. The main MC and the peripheral media centres at sport venues will be connected, both through hard lines and wireless technology, to the city-wide high-speed network and to the Games-specific wide area network (WAN) providing continuous live video, voice and data communications.

### Location

The MC will be strategically located in the MTCC, surrounded by numerous sport venues and the Pan American Village. The MTCC has over 55,000 m<sup>2</sup> (600,000 ft<sup>2</sup>) of usable space and all the amenities and services required by reporters and broadcasters. The MTCC is located adjacent to one of the designated media hotels, the InterContinental Toronto Centre. The other media hotels are the Westin Harbour Castle and the Renaissance Hotel (located at the Rogers Centre) which are less than 2 kms from the MTCC.

### Space, Layout and Services

The MC will have a minimum of 4,645 m<sup>2</sup> (50,000 ft<sup>2</sup>) available for the IBC and more than 1,858 m<sup>2</sup> (20,000 ft<sup>2</sup>) for the MPC. The main lobby

of the MC will have an information desk offering service in English, Spanish, Portuguese and French. The information desk will provide:

- daily schedules and results
- transportation information
- travel information
- lost and found
- responses to general inquiries

The main lobby area will also include a convenience store, post office/courier services, banking, restaurant/ food services (24 hours), translation services, newsstand featuring newspapers from Pan American countries, medical/pharmacy services, and a tour centre for members of the media who wish to visit Toronto area tourist locations. The MC will also include a media transport hub linking with sport and non-competition venues, as well as media parking.

#### Main Press Centre

The MPC will provide all services and facilities required by print, web and photo journalists including:

- Individual desks with power outlets and telephones
- Wi-Fi broadband capability throughout the facility with high-speed wired connections for laptops and printers
- On-site technology help desk
- Photocopiers and scanners
- Photo services centre including repairs and servicing, equipment loans, computer stations for editing photographs and image production
- News conference area with large high-definition TV screens that receive broadcast feeds from the venues
- Translation services

The MPC will house the media relations office of the Toronto 2015 Pan American Games Organizing Committee, the Canadian Olympic Committee and any other Pan American country that requires media office space. Each sport venue will also have workrooms set up for members of the accredited media.

#### International Broadcast Centre

The IBC will accommodate the needs of the host broadcaster and rights holders. Up to 140 m<sup>2</sup> (1,500 ft<sup>2</sup>) of raw space will be provided to each rights holder at no cost. Any additional space or improvements requested by the rights holders will be at their own expense in accordance with the rate card established by the host broadcaster. The raw space provided for the broadcast rights holders will be available during the Games period and for a reasonable time leading up to the Games period.

The IBC will include the following services:

- Booking office to serve the needs of the rights holders as provided by the host broadcaster
- Archives service to make available – for a nominal fee – footage that rights holders may not otherwise be able to obtain
- Master control to accept and distribute live venue feeds to the rights holders
- Secure space to store equipment

Each Toronto 2015 competition venue will feature the following broadcast services:

- A host broadcaster liaison to assist the rights holders on-site
- Commentator positions on a bookable basis
- A limited number of observer seats
- Mixed zone interview area for rights holders
- Electronic News Gathering (ENG) drop-off zones
- Dedicated parking

#### EXPERIENCE IN SPORT BROADCASTING

Canada has extensive experience in organizing and hosting national and international sport events, and Canadian television is recognized internationally for its world-class broadcasting standards. Over the last decade, Canada has provided the host broadcaster for numerous international events, including the Pan American Games as well as world championships in sports including Athletics, Aquatics, Road Cycling, Canoe/Kayak, Weightlifting, Skiing, Curling and Ice Hockey.

#### HOST BROADCASTER

The Toronto 2015 Organizing Committee will identify a host broadcaster that will provide Games coverage that meets the highest global standard for an event of the scale, scope and prestige of the Pan American Games. Canada is home to a number of potential host broadcaster partners, including three national broadcast television networks, two of whom have extensive experience as Olympic and/or Pan American Games broadcasters. Additionally, Canada has four general all-sports cable networks with outstanding credentials in producing live sports coverage. Cable television in Canada is extremely prevalent with almost 90% of Canadian homes receiving their television feeds by either cable or direct-to-home (DTH) technologies like satellite providers.

## **SECTION HIGHLIGHTS:**

The best technologies are both new and proven. Toronto 2015 will infuse technology that meets that standard through every aspect of the Games. Using advanced technology is the standard operating procedure in Toronto, a leading technology-adopting city that is the highest per-capita user of personal wireless devices in North America. The competitive Canadian telecommunications and technology sector ensures that the best products and services are readily available and the competition keeps prices low.





# TELECOMMUNICATIONS AND TECHNOLOGY

## CANADA: A WORLD LEADER IN TECHNOLOGY

Toronto 2015 recognizes that modern multi-sport games depend heavily on technology. The Toronto 2015 Games will integrate advanced and proven technology into every aspect of Games delivery. The Games Technology Group (GTG), the managers of all Toronto 2015 technology and related support, will be involved in the operations of every department. The GTG will also benefit from the significant pool of resources – particularly equipment and expertise – already available in Toronto, Canada’s technology and media hub.

Canada and Toronto are world leaders in telecommunications and technology. Toronto’s digital telecommunications infrastructure supports North America’s largest flat-rate local telephone calling area, the continent’s highest percentage of wire-line telecommunications converted to fibre optic cable, and the highest per capita use of wireless devices of any city in North America.

### CUTTING-EDGE AND PROVEN TECHNOLOGY

Toronto 2015 will employ proven technologies with trusted and experienced suppliers to provide reliable and redundant services in the following key areas of technology:

- Timing, Scoring and Results
- Telephone and Communications
- Web, Internet and Data Communications including transmission of broadcast signals
- Games Enabling Systems including Accreditation and Games Information
- Venue Technology including computers, office equipment, and sound and video devices
- Office Services
- Resource management including finance, staff, volunteers and equipment assets
- Transportation and logistics

## TORONTO 2015 PAN AMERICAN GAMES TECHNOLOGY

Toronto 2015 technology will bring fans closer than ever before to the action, providing timely and robust information through a wide variety of vehicles. It will provide the Games operations team with swift and accurate information at all times. It will enable media partners to serve their customers in the best ways possible. It will facilitate the movement of people and resources, the security of Games venues, and the successful marketing of the Games.

Toronto 2015 is also committed to meeting the high standards of international sport federations by using timing and scoring technologies that are both precise and reliable. All necessary equipment, including scoreboards, cables, optical fibre, TV generators, state-of-the-art timekeeping and data-handling technology, will be adapted to the requirements of each sport. In addition, on-site professionals will be available at all times to manage the technology. A Games technology provider will be responsible for the official timekeeping and data handling for every competition at every venue. The technology used for the Toronto 2015 Games will also ensure an efficient and effective accreditation process as well as a means of registering volunteers.

## THE BEST TECHNOLOGY FOR ALL GAMES PARTNERS

Toronto 2015 will work with the following stakeholders to ensure that the most reliable, accurate and timely information is available as they require:

- PASO
- Broadcasters
- Media
- Sport
- NOC's and Team Services
- Ticketing
- Venue Operators



## RATES AND COSTS

Due to vigorous competition in the Canadian telecommunications industry, the Canadian Radio-television Telecommunications Commission (CRTC) has deregulated the tariffs on telecommunications infrastructure and allowed market forces to push prices lower. The Organisation for Economic Co-operation and Development (OECD) has studied the prices of internet, business and residential telecommunications services and found that Canada has the lowest prices in the G7. This pricing context will ensure that rates provided to Games partners as part of the Toronto 2015 enhanced rate card system will be extremely competitive and offer excellent value.

## ACCREDITATION

Toronto 2015 will employ the most up-to-date and proven technology available to provide a highly accurate and efficient accreditation process. The goal will be to use technological solutions to ensure quality service and expedited processing for the athletes, teams, officials, volunteers, staff, media and other members of the PASO family.

To that end, Toronto 2015 will open its Accreditation Centre several months in advance of the Games to ensure that all accreditation is managed in a timely manner. As the dates of the Games approach, the second main Accreditation Centre will become operational at the Pan American Village. There will be smaller accreditation centres at the host hotel and the Media Centre, as well as an accreditation help desk at Lester B. Pearson International Airport.

### TORONTO REGION DIGITAL INFRASTRUCTURE:

- Voice
- Data
- Video
- High Speed Internet
- Fax
- Wireless phone – voice & data
- Wireless – Wi-Fi Hotspots
- Wireless – Fixed Wireless Broadband

### APPLIED CUTTING EDGE TECHNOLOGY

Predicting the use of specific technologies six years in advance of the 2015 Games is challenging, but Toronto 2015 is committed to building cutting edge technology into the planning and delivery of the Games in ways that are reliable and provide valuable enhancements to the Games experience.

While the next six years may see the following two examples usurped by newer and more applicable technologies, here are two ways that Toronto 2015 could use technology to enrich the Pan American Games experience for members of the PASO family.

**Connecting in the Digital Dining Hall:** Microsoft Surface is a technology that puts a powerful computer in a table top. Using just touches of a finger and movements of a hand, users can interact with Microsoft Surface, engaging the high-tech table as actively as any computer. Surface also interacts directly and wirelessly with personal hand-held devices like wireless phones and can transfer information from one unit to the other. An example of a way this technology could be applied would be to equip the tables in the Village Dining Hall with Microsoft Surface. This way, without even looking up from their meals, Village residents would be able to check Games results, schedules and live competition. They would be able to look up shuttle schedules, see meal ingredients, respond to a reporter's e-mail question, or send a press photo home to family members. They could check up-to-the-minute weather forecasts, book a trip to Niagara Falls or simply watch a funny video on YouTube. The only limit to the uses of Surface is the imagination.

**Handheld GPS Tracking:** At a large multi-sport games, NOC officials and chefs de mission need to keep track of everything from equipment to athletes. Toronto 2015 could make this process simple by providing GPS (Global Positioning System) tags for anything mobile and important. The tags could go with valuable equipment, the basketball team's shuttle or fellow NOC officials. With a quick glance at a BlackBerry handheld device (invented in Ontario and provided by Toronto 2015), an NOC official would be able to see exactly where those tags were and, with another quick touch, call or send an instant message to the person associated with that tag.

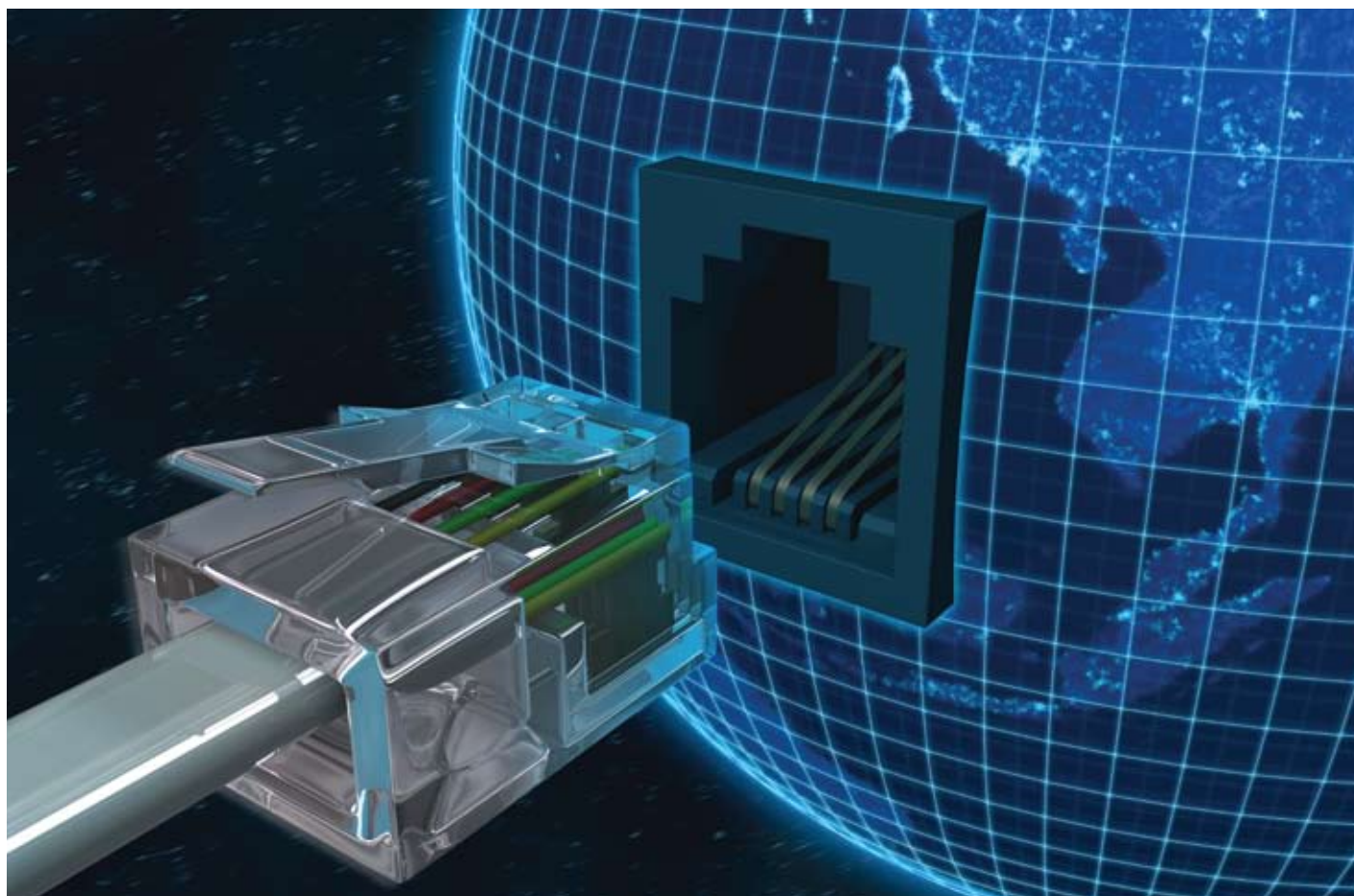

## **SECTION HIGHLIGHTS:**

Toronto 2015 has guaranteed commitments from all three levels of government – federal, provincial and municipal – accounting for 90% of the Games budget. With the Province of Ontario guaranteeing any budget deficits and a comprehensively precise budget forecast that incorporates 120 work packages and 2,000 lines of detail, Toronto 2015 is financially prepared for success.





THE TORONTO STOCK EXCHANGE

# FINANCE

**THE PROVINCE OF ONTARIO HAS COMMITTED TO BEING THE GAMES' DEFICIT GUARANTOR.**

## SOLID AND PREDICTABLE FINANCING

All three levels of government – federal, provincial and municipal – are solidly behind the Toronto 2015 Pan American Games and have committed to the Games' \$1.4 billion (Cdn) budget. In addition, the Province of Ontario has committed to being the Games' deficit guarantor, reflecting the strong commitment of both the government collectively and the Premier personally.

Secure financial support from stable government sources provides a rock-solid foundation for Toronto's bid and the 2015 Pan American Games even in the context of a turbulent global economy. It ensures confidence in budgeting and allows for aspiration in planning. It means that Toronto 2015 can execute the Games with an optimal blend of reliability and ambition.

## FINANCIAL OVERVIEW

The economy of the Province of Ontario benefits from a labour force that is attracted and sustained by a high quality of life and equipped with the education, skills and initiative needed to compete in today's knowledge-based marketplace. Centrally located within North America and offering a hospitable business climate, Ontario is a prime location for investment from all over the world.

Traditionally, northern Ontario's economy has focused on natural resources while southern Ontario (the region surrounding Toronto), with its proximity to the enormous U.S. market, has been heavily industrialized. Today, however, more Ontarians are employed in service industries than on assembly lines. The fastest-growing economic sectors in the province are business services, finance, education, health care, tourism and culture.

Ontario has an economy that derives its stability in part from its sheer size. The province has the third highest number of manufacturing workers of any jurisdiction in North America, after California and Texas. At over \$580 billion (Cdn), Ontario's GDP is greater than Switzerland's or Sweden's. Fifty-six percent of Ontario's workforce has a post-secondary education – the highest rate in the industrialized world – making the human resources in this market adaptable, high-performing and attractive to new businesses.

Toronto's strength comes from its economic diversity and its position as the centre of Canada's strong financial sector – five of the country's six largest banks have their headquarters in downtown Toronto, which is the third largest financial centre in North America. The Toronto region's GDP of \$222 billion (Cdn) is 19% of the national total. The City of Toronto itself had a total budget of \$11 billion (Cdn) in 2008.

The regional economy is making a significant move toward increasingly knowledge-based enterprises. Some of the most powerful examples of this in Toronto include university based research, technology companies and the rise of the "creative class." The professional services sector is now the largest generator of jobs in the City of Toronto.

## FINANCIAL GUARANTEES

In the Province of Ontario's Letter of Intent submitted to PASO at its October 2008 General Assembly, the Province of Ontario stated its commitment to guaranteeing the availability of funds for the organizing and hosting of the 2015 Pan American Games.

## GAMES BUDGET

Toronto 2015 has developed a budget that is responsible and manageable and yet allows the Games to include appropriate levels of innovation, ambition and pageantry. The business plan and financial statements were prepared by a team of financial and multi-sport games experts from the government and private sectors, including people with direct Pan American Games experience.

### GAMES BUDGET

The budget for the Toronto 2015 Pan American Games meets all of the recommendations and required elements in the PASO guidelines and regulations.

Detailed business plans have been prepared that include terms of reference, key activities, detailed costing, realistic assumptions and practical deliverables for the following business units:

- CEO office and board
- COC/CPC Relations and obligations
- PASO Relations
- Financial services
- Office administration
- Legal and risk management
- Staff recruitment, training and administration
- Host broadcaster and IBC
- Telecommunications
- Information technology, scoreboards and systems
- Audio, electronics and office equipment
- Sport operations
- Medical and doping control
- Venue overlay and adaptation
- Security
- Accommodation
- Transportation
- Materials Management
- Accreditation
- Village Services

Estimates for the overall business plan were built using a “bottom-up” methodology, and comprise more than 120 work packages and 2,000 lines of detail. Where appropriate, contingencies have been provided. Cost estimates for essential services including security from all governments have been included to ensure all costs are provided. All value-in-kind (VIK) contributions have been estimated, including the rental of all existing facilities owned by partners to the Games. The following table and charts outline revenue and expenditures related to the hosting of the 2015 Pan and Parapan American Games in Toronto.

## TORONTO 2015 PAN AND PARAPAN AMERICAN GAMES BUDGET \*

TORONTO 2015 EXPENDITURES (2014\$)			
CATEGORY	CDN\$	US\$	%
Capital and Legacy	707,994,000	556,412,311	49.55%
Operating (Including, Security and other Essential Services)	720,575,000	566,299,893	50.45%
<b>TOTAL</b>	<b>\$1,428,569,000</b>	<b>\$1,122,712,377</b>	<b>100%</b>

TORONTO 2015 REVENUE (2014\$)			
CATEGORY	CDN\$	US\$	%
<b>PUBLIC SECTOR CONTRIBUTIONS</b>			
Government of Canada	500,000,000	392,950,000	35%
Province of Ontario	500,000,000	392,950,000	35%
Municipal Governments, Universities , Other	281,881,000	221,530,278	20%
<b>GAMES REVENUE</b>			
Sponsorship	102,180,000	80,303,262	10%
Ticketing	38,247,000	30,058,317	
Licensing	3,652,000	2,870,107	
Media	2,609,000	2,050,413	
<b>TOTAL</b>	<b>1,428,569,000</b>	<b>1,122,712,377</b>	<b>100%</b>

OPERATING EXPENSES (2014\$)			
CATEGORY	CDN\$	US\$	%
Administration & Other	68,500,000	53,834,150	9%
Technology	34,811,000	27,357,965	5%
Sports Services (Medical & Technical)	20,871,000	16,402,519	3%
Venues	75,604,000	59,417,184	10%
Games Services (Transportation, Cost of Sales, Private Security Services)	55,739,000	43,805,280	8%
Workforce	84,861,000	66,692,260	12%
Communications & Awareness	14,741,000	11,584,952	2%
VIP & Protocol	2,449,000	1,924,669	1%
Ceremonies/Cultural	32,971,000	25,911,909	5%
Broadcast & Media	31,980,000	25,133,082	4%
Village Operations (Including overlay)	51,173,000	40,216,860	7%
Parapan American Games	37,555,000	29,514,475	5%
Contingency	42,281,000	33,228,638	6%
Essential Services (Includes security, Federal essential services, fire and emergency medical operations)	167,039,000	131,275,950	23%
<b>TOTAL</b>	<b>720,575,000</b>	<b>566,299,893</b>	<b>100%</b>

CAPITAL AND LEGACY COSTS (2014\$)			
CATEGORY	CDN\$	US\$	%
New Facilities	513,685,254	403,705,241	72%
Retrofits	124,308,525	97,694,070	18%
Legacy	70,000,000	55,013,000	10%
<b>TOTAL</b>	<b>707,994,000</b>	<b>556,412,311</b>	<b>100%</b>

NON ORGANIZING COMMITTEE BUDGET (2009\$)		
CATEGORY	CDN\$	US\$
West Don Lands (site of Village)	1,000,000,000	785,900,000

\* Note Canadian dollars were converted to US dollars using the Bank of Canada's noon rate on March 16, 2009, at an exchange rate of 0.7859



## REVENUE

■ GOVERNMENT OF CANADA [PUBLIC SECTOR CONTRIBUTION]	: 35%
■ PROVINCE OF ONTARIO [PUBLIC SECTOR CONTRIBUTION]	: 35%
■ MUNICIPAL GOVERNMENTS, UNIVERSITIES, OTHER	: 20%
■ GAMES REVENUE	: 10%



## OPERATING EXPENSES

■ ADMINISTRATION & OTHER	: 9%
■ TECHNOLOGY	: 5%
■ SPORTS SERVICES	: 3%
■ VENUES	: 10%
■ GAMES SERVICES	: 8%
■ WORKFORCE	: 12%
■ COMMUNICATIONS & AWARENESS	: 2%
■ VIP & PROTOCOL	: 1%
■ CEREMONIES/CULTURAL	: 5%
■ BROADCAST & MEDIA	: 4%
■ VILLAGE OPERATIONS	: 7%
■ PARAPAN AMERICAN GAMES	: 5%
■ CONTINGENCY	: 6%
■ ESSENTIAL SERVICES	: 23%

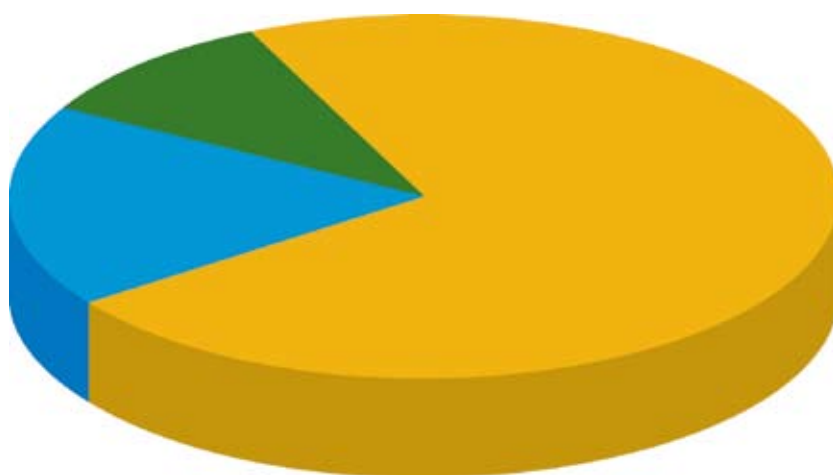

## CAPITAL & LEGACY COSTS

■ NEW FACILITIES	: 72%
■ RETROFITS	: 18%
■ LEGACY	: 10%

## **SECTION HIGHLIGHTS:**

The Pan American Games are one of the world's most valuable sport properties. That property needs to be appropriately protected to maintain its integrity and to enhance revenue. Canada's legal system will afford strong protection to the marks and properties of the Pan American Games, PASO and all participating NOC's and sponsors. In fact, the Government of Canada recently enhanced that legal protection in preparation for the Vancouver 2010 Olympic Winter Games.





CANADA • CA

CAN



# LEGAL AFFAIRS

## PROTECTION OF INTELLECTUAL PROPERTY

The laws of Canada and Ontario allow Toronto 2015 to protect the marks, symbols, emblems, trademarks and rights of all partners in the Pan and Parapan American Games including the Host City Organizing Committee, PASO, the IOC, Games sponsors, Games broadcasters and other Games partners. Canada's legal system also provides opportunities to resolve disputes amicably without relying on the court system by, for example, seeking arbitration. Toronto 2015 will work diligently to use these tools to protect the Games marks as well as the rights of both PASO and the Toronto 2015 Pan American Games.

## APPLYING THE *OLYMPIC AND PARALYMPIC MARKS ACT* TO TORONTO 2015

The Government of Canada enacted the *Olympic and Paralympic Marks Act* in 2007 to provide strong protection to the Vancouver 2010 Olympic and Paralympic Winter Games marks, as well as those of the Canadian Olympic Committee (COC) and Canadian Paralympic Committee (CPC). The act gives the Vancouver Organizing Committee considerable powers to prevent the use of Olympic marks by businesses or individuals seeking to profit from an unauthorized association with the 2010 Olympic Winter Games. It provides that either the COC or the CPC may make an application to the court for appropriate remedies, including injunctions and the recovery of damages or profits arising from infringement. Toronto 2015 will ask the Government of Canada to extend the same protection to the 2015 Pan American and Parapan American Games in Toronto.

## TRADE-MARKS ACT

The symbols, emblems, marks or other designations of PASO, the IOC and national committees are also covered by the Canadian government's *Trade-Marks Act*. This act provides trademark owners with exclusive rights to their registered marks and prohibits the use by others of marks that may confuse or erode the value of those marks. It protects against infringement and sets out civil penalties for violation. The act also expressly prohibits registration of a mark which is captured by the *Olympic and Paralympic Marks Act* and gives the COC and the CPC additional powers in trademark adoption and protection.

The *Trade-Marks Act* regulates situations involving the marks owned by PASO by applying the Convention for the Protection of Industrial Property (Paris Convention) to any mark that is well known in its field. Canada is a signatory member of the Union under the Paris Convention.

## AMBUSH MARKETING

Federal, provincial and local laws and by-laws will provide Toronto 2015 with focused legal tools to address specific ambush marketing tactics, to provide maximum protection to the industrial and intellectual property of the Games and PASO.



ALEXANDRA ORLANDO GOLD MEDALIST, PAN AMERICAN GAMES 2007  
PHOTO CREDIT: CANADIAN OLYMPIC COMMITTEE



## **SECTION HIGHLIGHTS:**

The Toronto market, sponsors and spectators are eager to support the Pan American Games. Toronto is Canada's most populous city and the 5th largest in North American with 8.1 million people in the region and 200 million within a day's drive or a three hour flight. The people in this market will see the 2015 Pan American Games as a once-in-a-lifetime opportunity. Toronto also has a unique ability to engage the sponsors of the Vancouver 2010 Winter Olympics just as those Games end and planning for Toronto 2015 begins.





# MARKETING

## TORONTO, ONTARIO: A MARKET READY FOR SUCCESS

Sell-out crowds, enthusiastic victory celebrations, large international audiences and engaged sponsors all help create the atmosphere of a successful Pan American Games. Beyond the atmosphere and feeling of the Games, however, these elements also help make exciting and high-quality broadcasts of the Games. They extend the reach of the Pan American brand and make vital contributions to the Games revenue and to the capacity of the organizers to deliver a great Games.

In the Province of Ontario and the City of Toronto, the Pan American Games will find a market ready to seize the opportunity to support the Games. Sponsorships, advertising space, tickets and even Pan American related merchandise will be in high demand as Ontarians embrace Toronto 2015 – their first international games in a lifetime.

**THE TORONTO REGION IS HOME TO OVER 37% OF CANADA'S MAJOR CORPORATE HEAD OFFICES. IT IS THE BUSINESS CAPITAL OF CANADA.**

Toronto is the heart of an enormous market that will provide the ticket buyers and marketing opportunities that will drive the 2015 Pan American Games. The Toronto region is home to 8.1 million people. Over 200 million people are within a three-hour flight or one-day drive of Toronto. Toronto also has a strong corporate base that is ready to sponsor the Games and has a history of supporting sport. Toronto is also Canada's main global city and therefore, home to branches of most multinational companies. This gives Toronto another potential base for sponsorship.

Toronto 2015's Games budget contemplates raising 10% of the total budget through sponsorship, ticketing, licensing, merchandising and broadcast. Revenue targets were developed by Canadian games and marketing experts with a view to size and opportunity of the Toronto market and the revenue raised by other events like the 1999 Winnipeg Pan American Games and the Vancouver 2010 Winter Olympic Games.

## AN AGGRESSIVE CAMPAIGN

A large and ready market is not, however, sufficient on its own to make the Pan American Games a success. Toronto 2015 will need to reach out to sponsors and ticket buyers, mounting an aggressive marketing campaign across the Western Hemisphere. This campaign will be supported by our television, corporate, radio print and government partners.

## ADVERTISING AND PUBLIC RELATIONS

Toronto 2015 will actively promote the Games and its various programs through a multi-faceted campaign that will proceed in waves at strategic times domestically and internationally to generate maximum exposure and return.

The campaign will be built around multiple advertising media – television, radio, newspapers, internet, wild posting (street-level advertising), social media, venue advertising, and public realm assets such as airports, trains, buses, benches and billboards.

Given the Toronto region's cosmopolitan character, a focal point of the Games advertising campaign will be cultural outreach. Toronto 2015 will create programs to engage and energize the region's multicultural communities in the lead up to and during the Games. The Canadian Olympic Committee (COC) has, for many years, managed a vibrant athlete speakers' bureau. Athletes are engaged as conference speakers, for interactive sport demonstrations and for marketing programs. Toronto 2015, in partnership with the COC, will actively promote the engagement of these "athlete ambassadors" who will fan out across the region to promote the Games.



**TORONTO FC, 2007**  
PHOTO CREDIT: TOURISM TORONTO - TORONTOWIDE.COM

The vibrant Toronto arts community will drive the Toronto 2015 Pan American Games Cultural Festival. The festival (detailed in Section 12) will bring to life the cultural mosaic of both the PASO nations and Toronto while also helping to build awareness and enthusiasm for the Games.

Toronto 2015 will create a local participation program called Friends of the Games that will reach out to small and medium-sized businesses, and to local business improvement associations to provide them with an avenue to get involved in and support the Games. The Friends program will not only attract financial resources but will increase the visibility and awareness of the Games throughout the region by connecting not only with the businesses that participate, but with their customers and employees as well. An important part of all Toronto 2015 promotion will be the inclusion of the values of Pan American sport: fair play, inclusion and accessibility.

## SPONSORSHIP

Sponsorship and sports marketing are well developed in Canada, particularly in the Toronto region. The COC has managed a successful Olympic marketing program for many years, partnering with Olympic Games organizing committees for Calgary (1988) and Vancouver (2010) to deliver multi-sport sponsorship programs. Toronto 2015 recognizes the importance of capturing the expertise and history of this program and will develop a joint marketing agreement with the COC.

Toronto 2015 has a unique opportunity to build upon the excitement of the 2010 Winter Olympic Games by offering Vancouver 2010 sponsors the opportunity to leverage their Olympic investments and provide continuity to their marketing efforts for the duration of another quadrennial. Sponsors of the Vancouver 2010 Olympic and Paralympic Games will be looking for a games connection to continue the momentum of their Vancouver sponsorships. The Toronto 2015 Pan American Games will be able to provide that sponsorship continuity. Just as the Vancouver 2010 Games conclude, Toronto 2015 will be stepping into the market, ready to build on the connections and programs that Olympic sponsors have built in support of amateur sport. This is a unique circumstance, one that Toronto 2015 will leverage for the benefit of the 2015 Pan American Games.

Toronto 2015 sponsorship revenue projections were created through the application of a multi-level process based on standardized sponsorship product categories such as soft drinks, financial services and telecommunications. The forecasts for cash sponsorship values grew from an assessment of previous comparable events held in Canada together with the relevant characteristics of Toronto and its surrounding market area.

## THE CURRENT “NATIONAL PARTNERS” AND “SUPPORTERS” OF THE 2010 VANCOUVER GAMES ARE:

### National Partners:

- Telecommunications – Bell Canada
- Financial Services – RBC (Royal Bank of Canada)
- Uniform and Retailer – HBC (Hudson’s Bay Company)
- Hardware – RONA
- Automotive – GM (General Motors)
- Petroleum Products – Petro Canada

### Supporters:

- Airline – Air Canada
- Planes and Trains – Bombardier
- Rail Freight – CP Rail
- Hospitality – Jetset Sports
- Office Document Solutions – Ricoh
- Coins – Royal Canadian Mint
- Minerals and Mining – Teck Cominco

## TICKETING

Ticketing estimates take into consideration a number of factors. Sport attendance projections were created based on previous comparable events held in Canada together with the characteristics of the Toronto area market. The current sport schedule maximizes attendance by balancing daily scheduling and ensuring that high-profile events do not conflict. The Toronto 2015 ticket pricing matrix takes into account the relative popularity of each sport, the capacity of each venue and the type of competition (preliminary rounds versus medal rounds). The goal of the price structure is to ensure that tickets generally skew to the “affordable family entertainment” level to enhance attendance and market reach. A transportation allowance was also factored in to provide spectators with access to public transit to and from the venues as part of the value of their tickets.

## LICENSING AND MERCHANDISING

A licensing program not only generates valuable revenue for the Games, but also plays an important role in building awareness of the Games locally, nationally and internationally. Toronto 2015 will generate a full licensing and merchandising program for the financial and promotional benefit of the Games by engaging partners with national and international reach.

The program will likely operate on a royalty model to ensure that Toronto 2015 does not have to operate its own retail outlets. The Toronto 2015 logo will be designed to be both appealing to the market and not unduly costly to replicate on the various product lines. Popular lines of

licensed products and anticipated shares of total sales have already been identified based on past experience and include: apparel (60%), pins (5%), novelty (10%), accessories (10%), headware (10%) and toys (5%). Sales estimates were based on wholesale prices and took into consideration the area market and anticipated Games attendance levels.

## BROADCAST

Canada is home to a sophisticated television programming environment with three national broadcast television networks. Currently, one broadcast network (CTV) and two cable sports networks (TSN and Rogers Sportsnet), along with a number of other digital channels,

are working together as partners in Canada's Olympic Broadcast Consortium for the Vancouver 2010 and London 2012 Olympic Games. Additionally, CBC – Canada's national broadcaster – has significant Olympic experience as it has served as Canada's Olympic broadcaster for a number of Games, including Beijing 2008.

Toronto 2015 will work with PASO to identify and capitalize on broadcast opportunities to ensure appropriate delivery of the Games across the country and internationally. For additional information see the section on Media Facilities and Services, Section 13.

## MARKS PROTECTION/AMBUSH MARKETING

Toronto 2015, in partnership with the COC, will protect the trademarks of PASO and the Games. For additional information, see the section on Legal Affairs, Section 16.



TORONTO'S DUNDAS SQUARE  
PHOTO CREDIT: TOURISM TORONTO

## **SECTION HIGHLIGHTS:**

The Toronto 2015 legacy will start long before the Games with innovative international programs that include regional coaching seminars and scholarships for athletes to train in Canada with Canadian athletes. Domestically, the Games will create much-needed amateur sport infrastructure and programs that involve diverse communities and youth. Toronto 2015 is also focused on leaving a powerful legacy in building the Games themselves, enhancing the Pan American brand and contributing to PASO's continuing growth.





# LEGACY

## BENEFITS THAT ENDURE

Great multi-sport games leave behind great legacies – legacies of facilities and programs and of personal and community development. The best games legacies have impacts that are both immediate and enduring.

Hosting the Pan American Games in Toronto will benefit sport at all levels. Across the Toronto region, new facilities will be built and existing ones improved. There will be an opportunity for greater sport participation at the community level as well as new opportunities for high-performance sport development at the provincial, national and international levels.

Toronto 2015 has developed a legacy plan with a dual focus – domestic and international – which spans the years leading up to the 2015 Games as well as the years following the Games.

The domestic legacy will be built upon the four pillars of the Canadian Sport Policy, the foundation for sport in Canada. These pillars are: participation, excellence, capacity and interaction. The domestic legacy will complement existing programming and help provide an unprecedented opportunity for sport in the Province of Ontario through better sport infrastructure and sport development.

The international legacy will be founded upon the PASO statutes, helping to improve sport in the Pan American nations. The international legacy will emphasize capacity building, training and development for athletes, coaches, officials and sport administrators.

## DOMESTIC LEGACY

### Pan American Village

The Pan American Village will create a new community on Toronto's waterfront, a neighbourhood that is economically, socially and environmentally sustainable. It will address a number of public policy objectives, including the reduction of urban sprawl, the creation of affordable housing and sports facilities, enhanced access to public transit and limiting the environmental impact of new development. It will provide its future residents with high quality sport facilities and amenities.

### Sport Infrastructure

The Games will create much needed new and updated sport facilities in Canada's most populous region. These facilities will be key community legacies that will launch athlete development through grassroots sport and increased physical activity within the general population.

While Toronto already has a core of sport venues built to support the city's participation in North America's premier sports leagues, the Games will enable the development of high performance sport facilities that fill the gap in training and competition venues for amateur and high performance athletes in Southern Ontario.

There are five major legacy facilities in the Toronto 2015 plan:

1. **The Canadian Sport Institute Ontario (CSIO)**, a partnership between the City of Toronto and the University of Toronto, co-located with the Pan American Games Aquatics Centre, will be the most powerful and multi-faceted element of the Toronto 2015 sport venue legacy. This multi-sport centre will provide interdisciplinary training, sport science, state-of-the-art equipment, sport medicine and advanced coaching to athletes striving to improve their performance and competitive results. The Centre will house a 14,000 m<sup>2</sup> (150,000 ft<sup>2</sup>) field house and accommodate all the testing and training facilities that athletes

need to achieve their greatest potential. The CSIO will become the preeminent national training centre for summer sport in Canada. University students and Toronto residents will also have access to the facility, providing participants of all skill levels with opportunities to develop their abilities.

2. **The Pan American Aquatics Centre**, co-located with the CSIO, features a dive tank and twin 10-lane, 50m pools. The Centre will become the premier aquatics facility in Canada and create a new capacity for hosting national and international competitive events with space for up to 10,000 spectator seats.
3. **Two additional 50m training pools**, one located on each side of the Toronto region, are also part of the venue legacy. Both high performance athletes and community members will have access to these facilities that will support both broader participation in aquatic sport and higher levels of competitive achievement.
4. **The Pan American Athletics Stadium** will not only create the capacity for hosting world-class competitions, but it will also have an extensive community legacy because of a plan to put the venue at the disposal of grassroots, youth and national-calibre athletes, while also creating the opportunity for a variety of non-sport uses.
5. **The Velodrome** adjacent to the Athletics stadium will be the only indoor 250m cycling track in Canada and one of only two in North America. The geographic location of the Velodrome allows for partnerships with nearby road cycling training facilities, thus creating a focal point for Cycling athletes from across Canada and beyond.

### **Sport Development**

The sport development legacy will provide all levels of sport in Canada with resources to increase participation and develop greater numbers of athletes who excel on the international stage. This aspect of the Toronto 2015 legacy will involve sport organizations primarily at the national and provincial levels. It will assist these organizations through a variety of avenues:

1. **Equipment and Assets** The Games will require the purchase of an estimated \$4 million (Cdn) of sport equipment, timing systems and other assets. At the conclusion of the Games, these resources will be made available to national, provincial and community sport organizations.

### **2. Transfer of Knowledge and Information Program.**

This program will coordinate the flow of information that will help sport organizations in all aspects of sport development and assist in planning future sport hosting and sport development activities.

### **3. Volunteer Recruitment**

To produce an event of the magnitude of the Pan American Games, Toronto 2015 will develop a cohort of both general and sport-specific volunteers. When the Games are over, this will leave a human legacy of qualified individuals, youth leaders and technical delegates. These people will represent the next generation of volunteers in the sport community. Additionally, these volunteers will be able to share their enhanced skills with their own communities, creating a lasting impact in sport, event management and the not-for-profit sector.

### **4. Legacy Endowment**

Toronto 2015 is committed to ensuring that the investment in the 2015 Pan American Games produces an enduring legacy. A key aspect of the legacy plan will be to secure the long-term viability of all Games legacy venues. In order to achieve this high degree of sustainability, Toronto 2015 will establish a \$70 million (Cdn) legacy fund (“Operating Trust”) that has two primary goals: to encourage and support the long-term development of amateur sport, and to support the ongoing operation and maintenance of major Games legacy facilities.

The 2015 Operating Trust is based on successful models for the 1988 Calgary and 2010 Vancouver Winter Olympic Games and will provide new opportunities for training, coach support, sport science and testing for Canadian high performance athletes. In addition, the trust will support the operation and maintenance of the legacy venues including the CSIO, the Pan American Aquatics Centre, the Pan American Athletics Stadium and the Velodrome. Through the support of the 2015 Operating Trust, legacy venues will:

- Promote sport and physical activity for life
- Integrate sport, coaching, sport science and sport medicine
- Allow recreational and high performance athletes to train in the same environment
- Host both world class and community events
- Ensure that legacy venues are both functional and financially viable for the long term.

## **ADDITIONAL DOMESTIC LEGACIES**

In addition to the domestic sport legacy, the Games will have a lasting impact in many other positive ways:

### **Culture**

The Games will incorporate cultural awareness initiatives and celebrations. Many of these, such as art exhibits and commissioned sculptural pieces, will remain as part of Toronto’s cultural mosaic long after the Games. The cultural component of the Games will also raise the international profile of local and Canadian artists and performers on the international stage and of Pan American artists and performers in Canada. It will establish new international relationships and partnerships and potentially usher new artistic stars onto the international stage. For more information on the cultural plan for the Games and beyond, please refer to Section 12.

### Youth Development

The 2015 Pan American Games will give young people in Toronto a range of unique opportunities, including the opportunity to experience the developmental potential of sport. Toronto 2015 will work to engage youth in the planning and staging of the Games. This will create a lasting human legacy of skills and experience that will mark the 2015 Games as the most youth friendly ever.

Opportunities will include:

- **Training and employment:** Programs will give young people practical job skills and opportunities to put those skills to work in all aspects of Games organization and delivery.
- **Leadership:** Youth will be involved in key volunteer positions in the planning and staging of the Games, allowing young people of diverse backgrounds to develop leadership skills and a greater stake in the future of their city.
- **Hosting an International Youth Sport Summit:** The Summit will provide developmental opportunities, share experiences and broaden horizons.
- **Sponsorship of community sport:** In priority areas, Toronto 2015 will support grassroots community sport development to enhance participation.
- **Support for coaching and leadership development:** This program will encourage more young people to become involved in sport.
- **An incentive to participate:** Bringing new athletic facilities to Toronto and giving youth opportunities to see world-class athletes will create a new awareness of the various sporting disciplines and the benefits of participation.

### Social Inclusion

The Toronto 2015 Games will foster an environment of inclusion – of broad and sincere involvement of the diverse communities that constitute the mosaic of Canada. The processes and relationships established in building the Games and in engaging the various communities and constituencies involved in planning and delivering the Games will create models that will endure in the Toronto region and beyond. Toronto 2015 will work to establish a consultative process that allows the region's diverse communities to engage in the decision-making process in respectful and meaningful ways.



### Urban Renewal

The new infrastructure built for the Games, primarily the Pan American Village, the CSIO, the Pan American Aquatics Centre and the paired Athletics Stadium and Velodrome, will help revitalize the communities in which they are located. These facilities will increase post-Games social inclusion opportunities through increased participation and grassroots programming, redevelop currently under-utilized areas of the urban landscape, redevelop brownfields, enhance the transportation network and create economic opportunity.

### Event Management

The event management requirements of a large-scale and multi-faceted event such as the Pan American Games will provide additional experience and training opportunities to Toronto's already large contingent of skilled workers and volunteers. It will expand the region's capacity for event hosting and accelerate the already significant economic opportunities in the region's service sector.

## INTERNATIONAL LEGACY

The Toronto 2015 international legacy plan is founded upon the PASO statutes. It will further strengthen the effort to improve sport in the Pan American nations and will provide opportunities for enhanced collaboration and cooperation among nations.

### Capacity-building

The Pan American Games can leverage existing international development opportunities and build capacity through legacy activities like:

#### 1. Games Hosting Internships

Individuals from potential future host organizing committees throughout PASO will have the opportunity to work in staff positions across disciplines with the Toronto 2015 Host Organizing Committee during the preparations for the 2015 Games. These placements will allow the "intern" to return home with knowledge that can help his or her community bid for, win and host sport and non-sport events. The internships could begin as early as 2012, with the program concluding at the close of the Games in 2015.

#### 2. Transfer-Of-Knowledge

Toronto 2015 will be an active partner with both the Canadian and PASO sport communities to contribute to the on-going development of resources available to communities and countries that plan to bid for and host major sport events. Toronto 2015 will offer one-on-one assistance to future hosts for both Pan American and regional games, as well as provide seminars and written materials on bidding and hosting best practices. The Toronto 2015 bid team is currently working with the 2009 Caribbean Games Organizing Committee, as well as the 2010 Central American and Caribbean Games Organizing Committee, on various games hosting areas such as accreditation systems and organizational development.

#### 3. Volunteer Training and Management

The Toronto 2015 Pan American Games will engage approximately 19,000 volunteers. All volunteers will participate in an innovative and comprehensive training program that will have the goals of helping volunteers learn not just what they need to know for the Games specifically, but also transferable skills that will enhance each volunteer's ability to be successful in subsequent volunteer and professional positions. Part of this enhancement will be an English-as-a-Second-Language (ESL) program for Canadian volunteers whose first language is not English so that they can develop verbal, comprehension and written skills.

In addition, the Toronto 2015 Pan American Games will provide language training in Spanish for non-Spanish speaking volunteers in order to enhance their ability to provide effective service during the Games.

The volunteer management modules developed for the 2015 Pan American Games will become part of a web-based service available to sport organizations throughout the PASO community. Specifically, the resource will include modules on key volunteer management issues like recruitment, roles and responsibilities, orientation, training and customer service.

### Training and Development

Canada currently offers a number of training and development initiatives throughout the PASO nations; Toronto 2015 will build on these programs. Toronto 2015 will work in conjunction with PASO and the Olympic Solidarity program to implement the initiatives outlined below:

#### 1. PASO Athlete Scholarships and Pre-Games Training Opportunities

The PASO Athlete Scholarship Program will provide funding to support high performance athletes in a variety of sports from Pan American nations to live and train in Canada with Canadian athletes in the years leading up to the 2015 Games. The scholarships will include access to appropriate training facilities and a full-time coach, room and board, medical and sport science assistance, accident and illness insurance, a basic allowance and return economy airfare from their home countries to Toronto.

Toronto 2015 will make funds available for the PASO Athlete Scholarship Program from 2012 through to 2015. The program will provide scholarship funding for each National Olympic Committee within PASO for up to 18 "athlete months." This means that each NOC could send one athlete to Canada to train for 18 months, or 18 athletes for one month each, or any combination in between.

Toronto 2015 is also committed to providing pre-Games access to facilities for the six months prior to the 2015 Games so that PASO athletes can familiarize themselves with their competition venues.

#### 2. Coaching Seminars and Clinics

Toronto 2015 will organize and host three regional conferences per year to be held in Pan American nations from 2011 through to 2014, and will cover all on-site costs (accommodation, meals and workshop fees) for NOC's to help offset the cost of their coaches' participation. Toronto 2015 will fund Canadian high performance coaches and sport experts to travel to Pan American nations to conduct these sessions.

Toronto 2015 will partner with the Coaching Association of Canada (CAC) for the provision of this program. The CAC has assisted a number of countries around the world in establishing coaching development systems based on Canada's National Coaching Certification Program (NCCP). With the assistance of Toronto 2015, the CAC will also play host to the International Council for Coach Education (ICCE) continental coaching conference for the Americas in Toronto in 2014, the year before the Toronto Games.

### 3. Sport Administration and Marketing Workshops

The Toronto 2015 Organizing Committee is committed to hosting three regional workshops per year in Pan American Countries from 2011 through to 2014 for PASO National Olympic Committees which focus on the administration of sport organizations. Sport management professionals from Canada will facilitate sessions on topics like sport marketing, grant application writing, communications, media relations and event planning. These workshops will be offered on an annual basis in the four years leading up to the Games, and Toronto 2015 will cover all on-site costs (accommodation, meals and workshop fees) for participants.

### STRENGTHENING THE PASO BRAND

Canada is a proud member of the PASO family, and Toronto 2015, along with the Canadian Olympic Committee, is committed to building the profile and further strengthening the brand of the Pan American Games both within Canada and beyond. Toronto 2015 has committed to working with Guadalajara 2011 to broadcast the 2011 Games in Canada to raise awareness of the event in the quadrennial leading into the 2015 Games. The 2011 broadcast would feature up to 50 hours of coverage across Canada, and Toronto 2015 will increase that broadcast coverage to over 300 hours for the 2015 Games.



## **SECTION HIGHLIGHTS:**

Toronto 2015 will deliver on its vision of hosting an excellent Parapan American Games by fully integrating the planning and marketing of the Pan and Parapan American Games to ensure consistent excellence. Parapan American athletes and coaches will benefit from pre-Games programs offering training opportunities and equipment grants. The Toronto 2015 Parapan American Games will also ensure that athletes have the classification opportunities they need to compete internationally.





# PARAPAN AMERICAN GAMES

## THE TORONTO 2015 VISION

Canada has a strong tradition of Paralympic Sport – a tradition distinguished by being the home of International Paralympic Committee Founding President Bob Steadward – a tradition that will take a significant step forward with the Vancouver 2010 Paralympic Winter Games. The vision for the Toronto 2015 Parapan American Games is to build on Canada's tradition in Paralympic Sport and to work with PASO to build a great Games, expand the brand and quality of the Parapan American Games, and foster an environment of inclusiveness that reaches out to diverse communities both within Canada and throughout PASO.

### TRAVEL SUPPORT GRANT

Toronto 2015 will provide a travel support grant that will give NOC's real budget relief and enable investment in teams and athletes instead of airfare.

The Toronto 2015 Parapan American Games will deliver a high performance sporting event that matches and enables the excellence of the competing athletes. By creating equitable, accessible and healthy living, training and competition environments, Toronto 2015 will enhance every athlete's opportunity to achieve his or her competitive goals.

### DISABILITY AWARENESS

All staff and volunteers involved in the Toronto 2015 Parapan American Games will participate in mandatory disability and diversity awareness training to ensure that Parapan American athletes, officials and family receive barrier-free customer service.

The Toronto 2015 Parapan American Games will begin within 12 days following the Pan American Games and planning of the two Games will be concurrent. The Toronto 2015 Organizing committee will be integrated, with each functional area responsible for planning and delivering services for both the Pan American and Parapan American Games. This will ensure that the same high standards of service delivery and venue excellence apply to all teams and athletes who come to Toronto to compete in either the Pan American or Parapan American Games.

In order to achieve the ambitious vision of the Toronto 2015 Parapan American Games – thus providing elite competition as well as qualifying and classification opportunities at home in the Western Hemisphere – Toronto 2015 will take specific steps to reduce barriers to participation.

## FOSTERING INCLUSION - GROWING PARALYMPIC SPORT

### Development of the Paralympic Movement

Toronto 2015 recognizes that Paralympic Sport often requires highly-specialized and therefore expensive equipment. Toronto 2015 will create a Paralympic Sport Equipment Fund that offers grants of up to \$5,000 to PASO NOC's in order to help develop Paralympic Sport throughout the Americas and the Caribbean. These grants will be available in 2013.

### Paralympic Sport Coach Development

Toronto 2015 will allocate specific resources to support Canadian high performance coaches in travelling to Pan American nations to conduct coaching clinics and workshops. For more details on the Coach Development Workshops, please refer to Section 18.



PAT ANDERSON, WHEELCHAIR BASKETBALL, RIO PARAPAN AMERICAN GAMES 2007.  
PHOTO CREDIT: KEVIN BOGETTI-SMITH

### Paralympic Sport Innovation Conference

Toronto 2015 will host a conference designed to bring together leaders in the Paralympic Sport movement to discuss and interact with new technologies with an influence on Paralympic Sport. The conference will take place at least a year before the 2015 Parapan American Games.

### More Opportunities for Classification

In most cases, a Paralympic Sport athlete can only obtain the classification required to compete internationally by participating in an international competition staffed by certified classifiers. By providing classification in every sport on the Parapan American program, Toronto 2015 will make it easier for Paralympic Sport athletes throughout PASO to receive proper classification in advance of the 2016 Paralympic Games.

### SPORT PROGRAM

The Opening Ceremony for the Toronto 2015 Parapan American Games will be held at the University of Toronto’s Varsity Stadium on Friday, August 7th and the Closing Ceremony on Friday, August 14th.

The Toronto 2015 Parapan American Games sport program will build on the programs of previous hosts. Toronto 2015 will also work with the International Paralympic Committee (IPC) and PASO to provide the most extensive Parapan American Games program possible. The Toronto 2015 Parapan American Games proposed sport list includes:

- Athletics
- Aquatics (Swimming)
- Boccia
- Football (5 aside & 7 aside)
- Goalball
- Judo
- Power Lifting
- Table Tennis
- Volleyball – Sitting
- Wheelchair Basketball
- Wheelchair Tennis

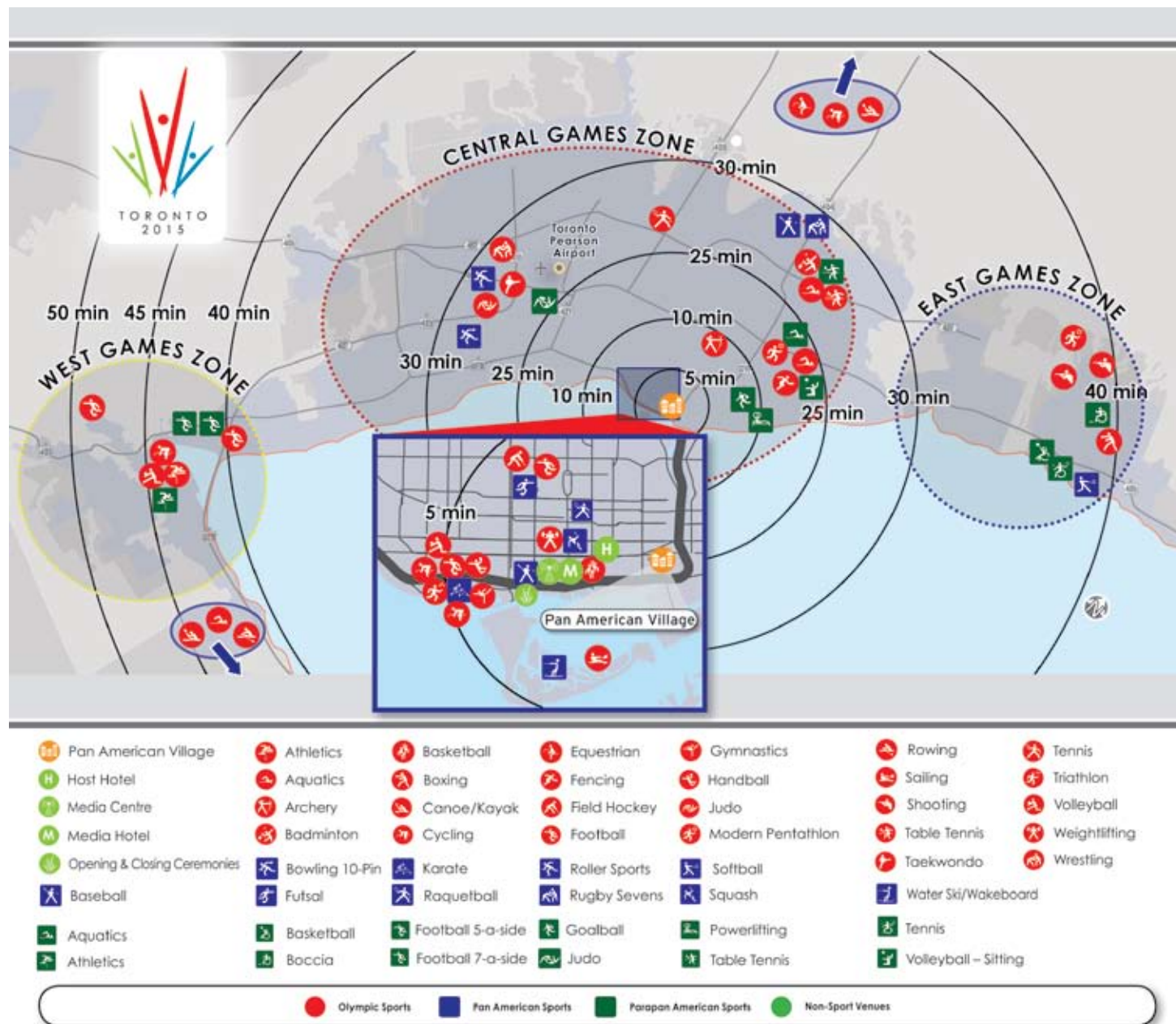

## AUGUST AVERAGE WEATHER CONDITIONS

- Daytime high: 25.3 degrees Celsius (77.5F)
- Average daily temperature: 21.3 degrees Celsius (70.3F)
- 4 days in August with rain greater than 5mm

## VENUES

All of the Toronto 2015 Pan and Parapan American Games venues – new and renovated – will meet or surpass the requirements of applicable Ontario and Toronto accessibility and building codes, as well as the National Building Code of Canada (NBCC), all of which have strong provisions for accessibility and are among the highest national standards for access in the world.

Toronto 2015 will consult with the IPC and each Paralympic Sport's International Federation to ensure that competitive venues and fields-of-play meet or exceed the technical specifications required.

In addition to the new and existing sport venues that will be part of the Toronto 2015 Parapan American Games, two additional existing facilities – each designed specifically for athletes with



↑ LARRY MATTHEWS, VOLLEYBALL SITTING, 2007 RIO PARAPANAMERICAN GAMES  
PHOTO CREDIT: KEVIN BOGETTI-SMITH

a disability – will be part of the Games. Facilities overlay will also be sensitive to meeting the needs of spectators with disabilities.

**The Abilities Centre**, already under development and scheduled for completion in 2011, will provide sport, physical rehabilitation and recreational activities, services and programs to people of all ages and abilities. The Centre will follow the principles of Universal Design and incorporate training tracks with perimeter support rails, pools with easy wheelchair access, and resource areas with features that accommodate sight and other sensory impairments. Equipment designed to meet the strength and fitness requirements of Pan American athletes with a disability will also be incorporated into the centre.

**Variety Village** has been an active home of Paralympic Sport for years, recently serving as the host of the 2008 Ontario Para Sport Summer Games and the 2009 Canadian Junior Weightlifting Championships. The Variety Village centre, with its extensive specialized strength training, practice and competition facilities, has supported several Canadian Paralympians during their development into international-calibre competitors.

## PARAPAN AMERICAN VILLAGE

The Parapan American Village will open 10 days before the first day of the Games and close 3 days after the Closing Ceremony, in accordance with PASO regulations.

### The operational dates of the Parapan American Village will be:

Tuesday, July 28, 2015 – Monday, August 17, 2015

The Parapan American Village will serve as the home for the approximately 2,000 athletes and team officials who will participate in the Games. All Parapan American Village facilities in use during the Games will be fully accessible and provide a barrier-free environment for Village residents and visitors to the International Zone.

In addition to regular Village Polyclinic services, Parapan athletes will also have access to medical specialists through the Polyclinic. Toronto 2015 will also provide PASO and all NOC's with an "enhanced" rate card system. The rate cards will ensure that members of the PASO family have a convenient system for obtaining the services and resources they will require in Toronto. The rates will be negotiated in advance to ensure the best prices possible.

## HEALTH INSURANCE PLAN FOR THE PARAPAN AMERICAN FAMILY

Toronto 2015 will provide a health insurance plan for all members of the PASO family to cover the costs of medical and dental care, including:

- Medical assistance in any of the reference hospitals (including emergency surgical procedures and intensive care)
- Medical assistance in the Games venues
- Treatment and tests in specialized clinics (when not offered at the polyclinic),
- Urgent and necessary dental services, and
- Medications



↑ JESSICA MATASSA, ATHLETICS, 2007 RIO PARAPAN AMERICAN GAMES  
PHOTO CREDIT: KEVIN BOGETTI-SMITH

## SECURITY

The same security planning team will work on the Pan American Games and the Parapan American Games. The security plan will be specific to the Parapan American Games and will reflect the level of threat and the number of active venues associated with the Games. Toronto 2015 will establish Parapan-specific fire and disaster response protocols for the Parapan American Village, all venues and other Games facilities. These protocols will include provisions for, as necessary, the rescue or evacuation of people with disabilities.

There will be ample secure storage in the Village to allow teams and individual athletes to store equipment.

## TRANSPORTATION

Toronto's Pearson International Airport provides significant resources to travellers who require assistance. The Airport Customer Assistance Program (ACAP) was specifically designed to help people with a disability. A number of assistive elements in the airport's design, such as specific easy-access drop-off points and Teletype phones (TTY) on all levels, make using the airport more convenient and comfortable for people with a range of abilities.

All members of the Parapan American family will have access to adapted transportation (such as kneeling buses) based on their accreditation. A dedicated transfer system will transport Parapan American athletes between the airport and the Parapan American Village.

Toronto 2015 recognizes the critical importance of transportation to the overall success of the Games and will provide safe, reliable, accessible and sustainable transportation for all user groups.

Parapan American athletes will have access to a dedicated transportation system for travel between the Village and the sport venues. Athletes competing as part of a team (such as wheelchair basketball) will travel as a single group in dedicated team buses. Every transportation mode and strategy will take into account the requirements of moving equipment so that athletes and equipment move in the same vehicle whenever possible or, at a minimum, with the equipment in a following vehicle.

## CUSTOMS AND IMMIGRATION

The same customs and immigration processes and procedures will apply to the Parapan American Games as apply to the Pan American Games. Please see Section 3 for complete details.

Service dogs that are certified as a guide, hearing or other, are not subject to any restrictions for importation where the person importing the dog is the user of the dog and accompanies the dog to Canada.

## MARKETING

From the outset of Toronto 2015's marketing program, the Parapan American Games will be presented as an integral part of both the domestic and international offering to potential sponsors, partners, advertisers and ticket buyers who may be interested in the Pan American Games, the Parapan American Games or both.

For more information on the marketing plan for the Games, please refer to Section 17.

## TRAVEL SUPPORT GRANT

Toronto 2015 will provide a travel support grant that will give NOC's real budget relief and enable investment in teams and athletes instead of airfare.

## LEGACY

The 2015 Parapan American Games will create a number of Paralympic Sport-specific legacies:

### Accessible Facilities

A number of new, fully-accessible training and competition venues are part of the Pan/Parapan American Games venue development plan. This will benefit not only the future development of athletes, but also create sites for hosting future Parasport events.

### Training and Development

One of the key barriers to the development of both classifiers and technical officials in Paralympic Sport is the relative infrequency of international competition in the Pan American region. The Parapan American Games offers a unique opportunity to encourage the development and classification of athletes with a disability and develop a large number of Paralympic Sport officials. Toronto 2015 will work with the Canadian Paralympic Committee and domestic National Sport Organizations to increase the number of international classifiers in advance of the 2015 Parapan American Games. This will result in a great number of classified athletes and qualified officials throughout the PASO nations.

### Grassroots Parasport Development

The 2015 Parapan American Games offer a significant platform and opportunity for promoting awareness of disabilities, of active lifestyles for people living with disabilities and, of course, of Paralympic Sport itself. Using an awareness campaign designed to activate hundreds of new participants in Paralympic Sport at the community level, Toronto 2015 will partner with the Canadian Paralympic Committee to test a pilot program for building awareness and participation with a goal of sharing the identified best practices with national and international sport organizations through various media, including the Paralympic Sport Innovation Conference.

### Volunteer Recruitment

The concurrent volunteer recruitment process for the Pan American and Parapan American Games will expose new volunteers to working with people with disabilities. This will create a new cohort of volunteers who have the experience and expertise to continue volunteering in that arena following the close of the Games.

## ORGANIZATION AND MANAGEMENT

The Toronto 2015 Parapan American Games will be an integral aspect of the overall 2015 Pan American Games experience. The same organizing committee will manage both the Parapan American and the Pan American Games to ensure that the quality of Games delivery and service is consistently excellent. The parasport movement, both within Canada and throughout the Western Hemisphere, will be well-represented in the contingent of advisors and experts upon whom the board of directors and the senior Games management will rely in drafting the plans for both the Pan and Parapan American Games.

PARAPAN AMERICAN GAMES SCHEDULE										
AUGUST										
			Fri	Sat	Sun	Mon	Tues	Wed	Thu	Fri
EVENT	VENUE NAME	PAGE	7	8	9	10	11	12	13	14
OPENING CEREMONIES	VARSITY STADIUM		●							
CLOSING CEREMONIES	VARSITY STADIUM									●
ATHLETICS	PAN AMERICAN ATHLETICS STADIUM	212		●	●	●	●	●	●	●
BOCCIA	DURHAM COLLEGE	214				●	●	●	●	
FOOTBALL 5-A-SIDE	SHERWOOD PARK	216		●	●	●	●	●	●	●
FOOTBALL 7-A-SIDE	SHERWOOD PARK	216		●	●	●	●	●	●	
GOAL BALL	VARIETY VILLAGE	218				●	●	●	●	●
JUDO	HERSHEY CENTRE	220					●	●	●	
POWERLIFTING	VARIETY VILLAGE	222	●	●	●					
SWIMMING	PAN AMERICAN AQUATICS CENTRE	224		●	●	●	●	●	●	
TABLE TENNIS	CENTENNIAL COMMUNITY CENTRE	226		●	●	●	●	●	●	
VOLLEYBALL - SITTING	CANADIAN SPORT INSTITUTE ONTARIO	228		●	●	●	●	●	●	●
WHEELCHAIR BASKETBALL	ABILITIES CENTRE	230		●	●	●	●	●	●	
WHEELCHAIR TENNIS	IROQUOIS SPORTS PARK	232		●	●	●	●	●	●	

● Competition ● Finals (may include competitions on these days) ● Ceremonies



**SPORT:**  
**ATHLETICS**

**VENUE: Pan American Athletics Stadium**

As an important new development, the Pan American Stadium will be a significant project as part of the Games' Venue Plan, and provide a significant legacy directly related to hosting the 2015 Games.

The new 15,000-seat stadium will include a leading-edge 400m running track with all the required areas for throwing and jumping disciplines. An adjacent warm-up training track, replicating the features of the Stadium will be added to the site to create a premier national training centre for Athletics, capable of hosting national and international events following the Games.

**> SPORT & VENUE SPECIFICATIONS**

**CURRENT STATUS**

- New build
- Construction Status: Completed by 2014
- Current/Future Owner: City of Hamilton

**VENUE HIGHLIGHTS**

- Meets all International Federation specifications
- Seating Capacity: 15,000
- Distance from village: 45 minutes / 68km
- Parking spaces: 8,400

**CURRENT AND POST GAMES USE**

- Post Games, the Pan American Stadium will remain as a national training centre supporting national sport development objectives, and capable of hosting major national and international events.
- The facility will also be a significant multi-purpose community asset that will serve the broad needs of the region.



**> COMPETITION SCHEDULE**

AUGUST								
Day	Fri	Sat	Sun	Mon	Tues	Wed	Thu	Fri
Date	7	8	9	10	11	12	13	14
Athletics		●	●	●	●	●	●	●

- Finals (may include competitions on these days)

> COMPETITION SITE PLAN

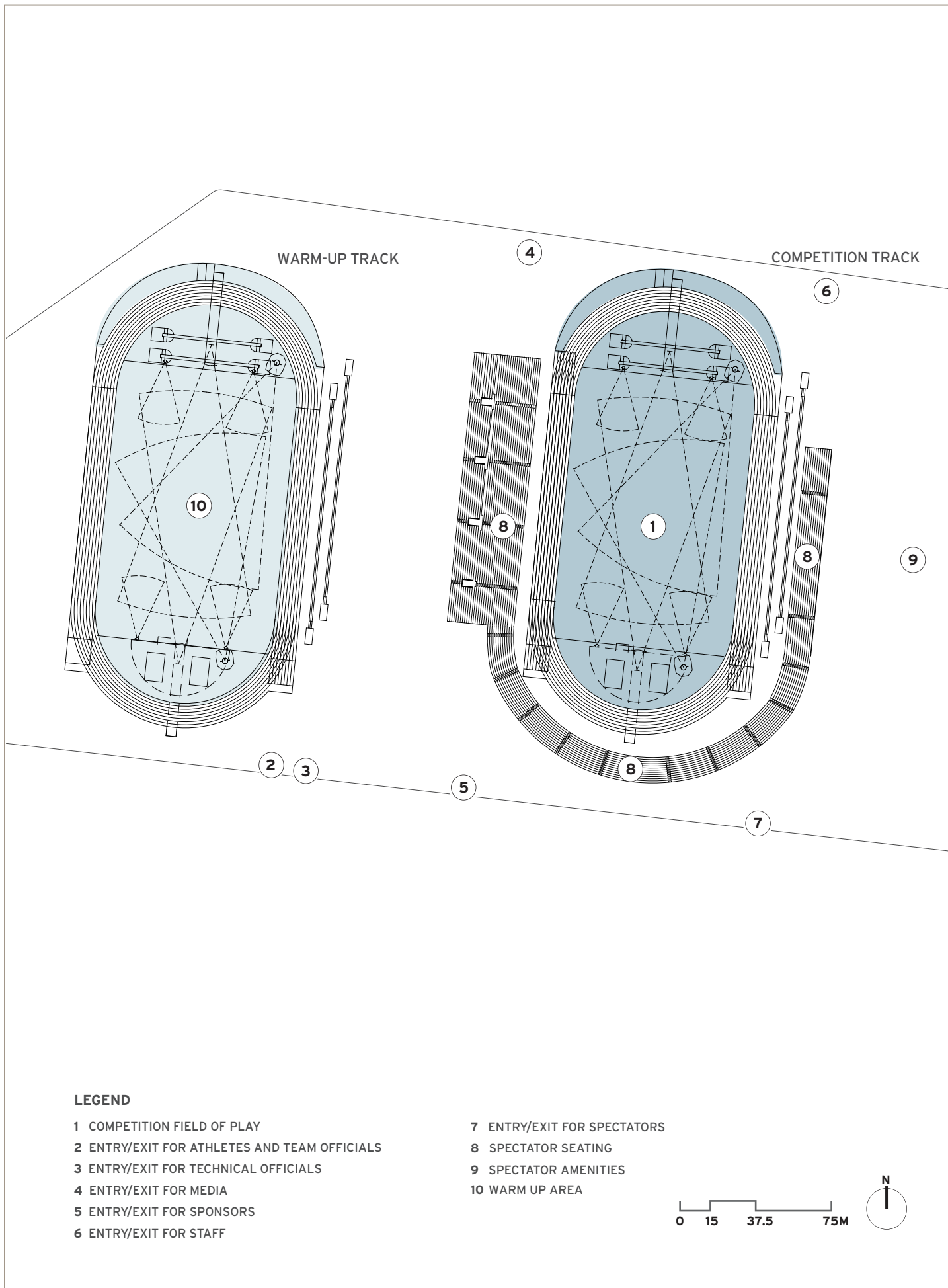

**LEGEND**

- |  |                             |
|--|-----------------------------|
| 1 COMPETITION FIELD OF PLAY                  | 7 ENTRY/EXIT FOR SPECTATORS |
| 2 ENTRY/EXIT FOR ATHLETES AND TEAM OFFICIALS | 8 SPECTATOR SEATING         |
| 3 ENTRY/EXIT FOR TECHNICAL OFFICIALS         | 9 SPECTATOR AMENITIES       |
| 4 ENTRY/EXIT FOR MEDIA                       | 10 WARM UP AREA             |
| 5 ENTRY/EXIT FOR SPONSORS                    |                             |
| 6 ENTRY/EXIT FOR STAFF                       |                             |

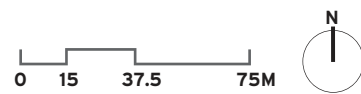



**SPORT:**  
**BOCCIA**

**VENUE:** Durham College

The Durham College Campus Recreation and Wellness Centre (CRWC) opened a 8,400 m<sup>2</sup> expansion in June 2007, including a 2,600 m<sup>2</sup> gymnasium capable of hosting major events.

With recent experience hosting the 2008 Provincial Boccia Championship, the venue has developed the proper expertise to deliver a successful event for the Games providing athletes and spectators with the required amenities.



> **SPORT & VENUE SPECIFICATIONS**

**CURRENT STATUS**

- Existing
- Renovated in 2007
- Current/Future Owner: Durham College

**VENUE HIGHLIGHTS**

- Meets all International Federation specifications
- Seating Capacity: 2,000
- Distance from village: 40 minutes / 52km
- Parking spaces: over 1,000

**CURRENT AND POST GAMES USE**

- Currently used for college athletics, recreation, as well as local community participation and offers state of the art accessibility features.
- Hosting Experience:
  - 2008 Boccia Provincial Championship
  - 2007 Special Olympics
  - 2007 - Healthy Athletes Expo for Special Olympics athletes



> **COMPETITION SCHEDULE**

AUGUST								
Day	Fri	Sat	Sun	Mon	Tues	Wed	Thu	Fri
Date	7	8	9	10	11	12	13	14
Boccia				●	●	●	●	

- Competition
- Finals (may include competitions on these days)

> COMPETITION SITE PLAN

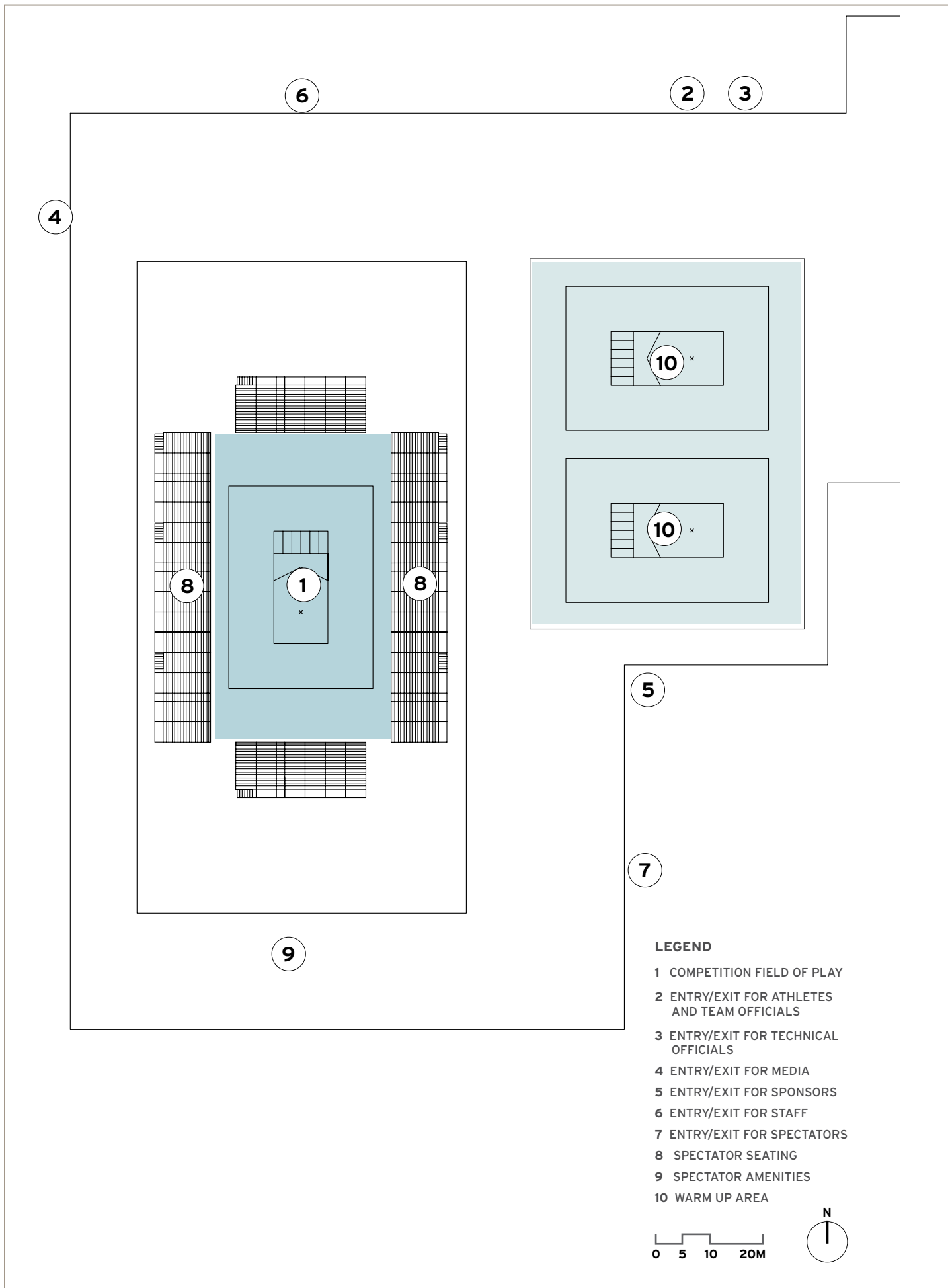



## SPORT: FOOTBALL



## 5-A-SIDE AND 7-A-SIDE

### VENUE: Sherwood Park

The Pan American Games will be the catalyst for the development of a new outdoor complex for football and other field sports.

At 10,000 seats, this new multi-field development will provide high level competition fields where participants and spectators will enjoy the 'beautiful game'. Training and warm up facilities will also be available on site for participating teams.

### > SPORT & VENUE SPECIFICATIONS

#### CURRENT STATUS

- New Build
- Construction status: Completed by 2014
- Current/Future owner: City of Burlington

#### VENUE HIGHLIGHTS

- Meets all International Federation specifications
- Seating Capacity: 10,000
- Distance from village: 40 minutes / 52 km
- Parking spaces: over 2,500

#### CURRENT AND POST GAMES USE

- This venue will become a field sport legacy project that will provide a significant venue that will be utilized by high performance sport athletes, sport development programs and community groups.



### > COMPETITION SCHEDULE

AUGUST								
Day	Fri	Sat	Sun	Mon	Tues	Wed	Thu	Fri
Date	7	8	9	10	11	12	13	14
Football 5-A-Side		●	●	●	●	●	●	●
Football 7-A-Side		●	●	●	●	●	●	●

- Competition
- Finals (may include competitions on these days)

> COMPETITION SITE PLAN

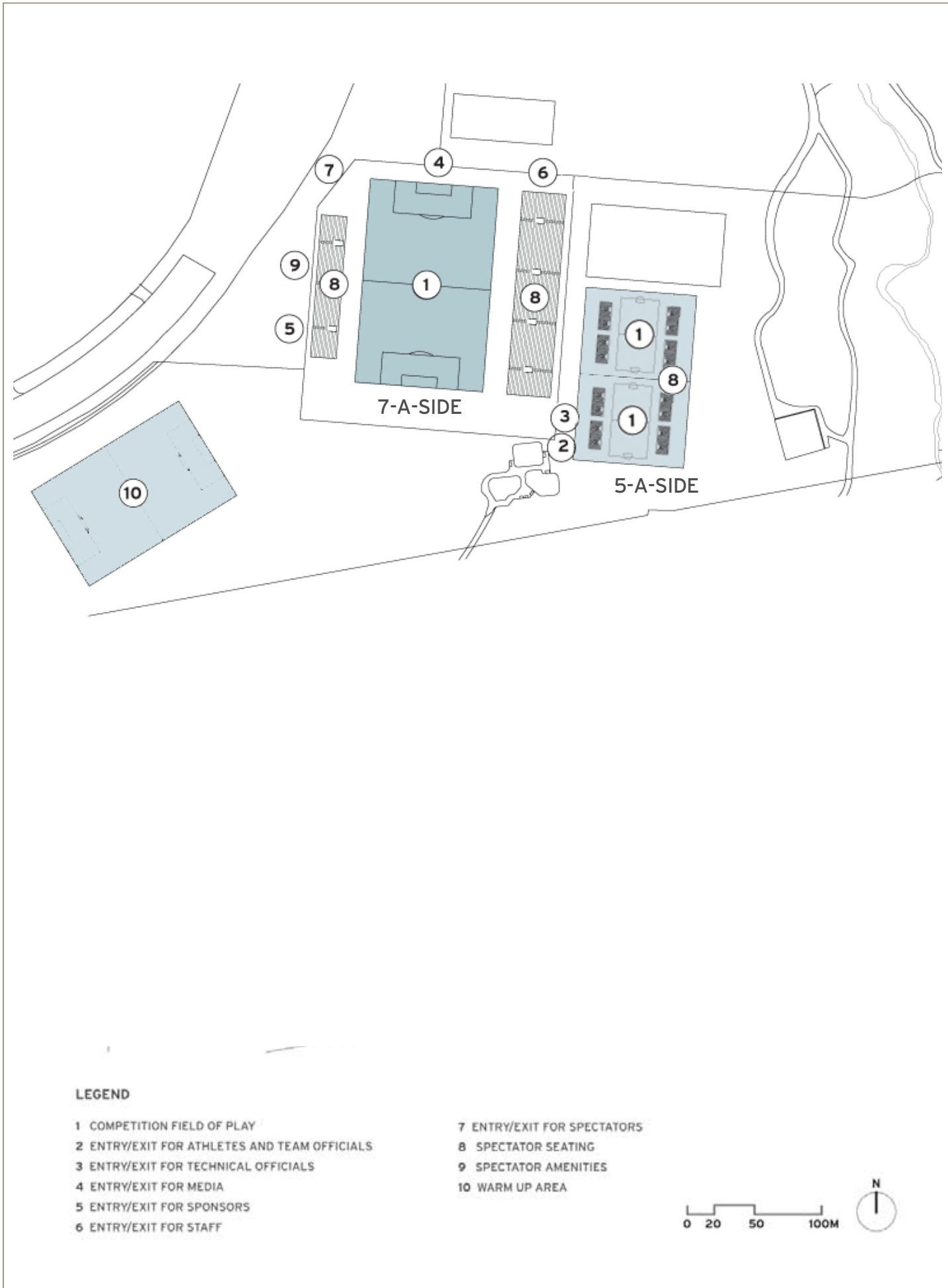

**LEGEND**

- |  |                             |
|--|-----------------------------|
| 1 COMPETITION FIELD OF PLAY                  | 7 ENTRY/EXIT FOR SPECTATORS |
| 2 ENTRY/EXIT FOR ATHLETES AND TEAM OFFICIALS | 8 SPECTATOR SEATING         |
| 3 ENTRY/EXIT FOR TECHNICAL OFFICIALS         | 9 SPECTATOR AMENITIES       |
| 4 ENTRY/EXIT FOR MEDIA                       | 10 WARM UP AREA             |
| 5 ENTRY/EXIT FOR SPONSORS                    |                             |
| 6 ENTRY/EXIT FOR STAFF                       |                             |

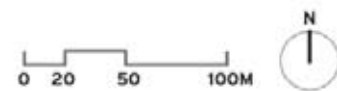



## SPORT: GOAL BALL

### VENUE: Variety Village

Variety Village is a specialized fitness and life skills facility designed to assist people of all abilities develop independence, self-confidence and a feeling of belonging. Variety Village also provides a high-performance training venue for some of Ontario's high performance athletes with disabilities who compete at the national and international level.

This multi-purpose facility will be home to the sports of Goalball and Powerlifting, offering a wide variety of specialized equipment to assist athletes in their preparation for the Games.



### > SPORT & VENUE SPECIFICATIONS

#### CURRENT STATUS

- Existing
- Current/Future Owner: Variety, the Children's Charity

#### VENUE HIGHLIGHTS

- Meets all International Federation specifications
- Seating Capacity: 1,000
- Distance from village: 10 minutes / 12km
- Parking spaces: over 1,000

#### CURRENT AND POST GAMES USE

- Variety Village is a leading charity for young people of all abilities and their families. In its present form it includes a 15,300 m<sup>2</sup> exercise and training complex offering services to over 6,000 members.
- Hosting Experience:
  - 2008 Ontario Paraspport Summer Games
  - 2009 Canadian Junior Weighlifting Championships

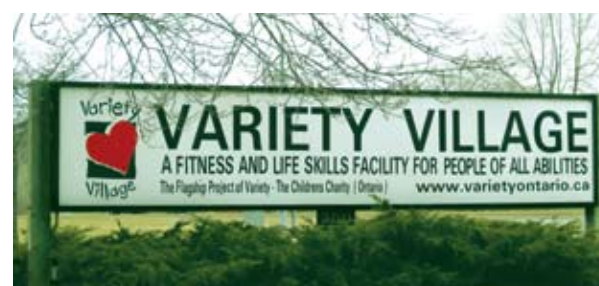

### > COMPETITION SCHEDULE

AUGUST								
Day	Fri	Sat	Sun	Mon	Tues	Wed	Thu	Fri
Date	7	8	9	10	11	12	13	14
Goal Ball				●	●	●	●	●

- Competition
- Finals (may include competitions on these days)

> COMPETITION SITE PLAN

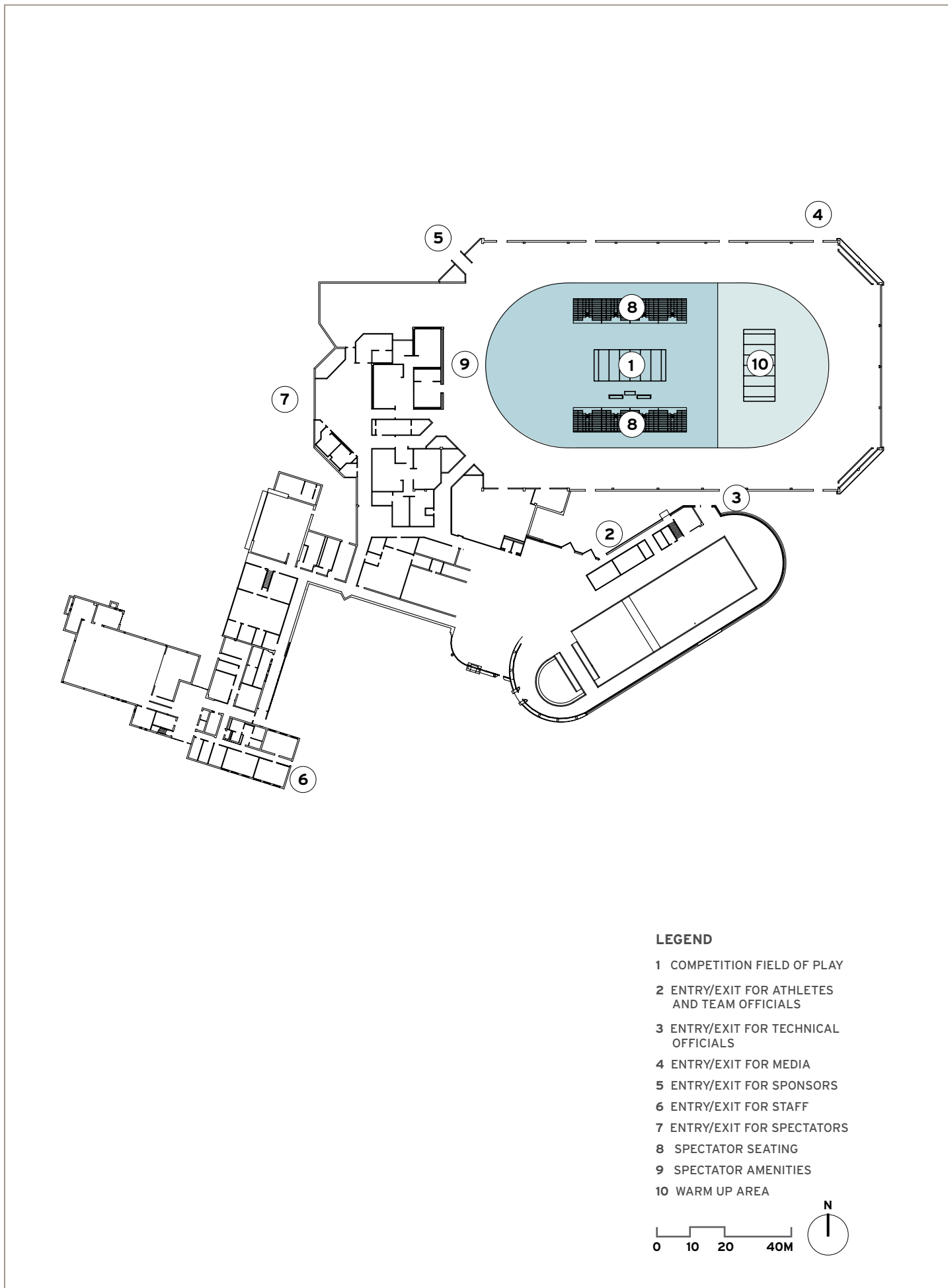



**SPORT:**  
**JUDO**

**VENUE:** Hershey Centre

The Hershey Centre is a multi-sport facility at the forefront of showcasing local, national and international talent in excellent facilities including arenas, spectator facilities, gymnasia and a FIFA regulation indoor turf field.



> **SPORT & VENUE SPECIFICATIONS**

**CURRENT STATUS**

- Existing
- Built in 1998
- Current/Future Owner: City of Mississauga

**VENUE HIGHLIGHTS**

- Meets all International Federation specifications
- Seating Capacity: 5,400
- Distance from village: 27 minutes / 32km
- Parking spaces: 1,920

**CURRENT AND POST GAMES USE**

- This multi-sport facility will continue to serve the needs of community users and high performance athletes.
- Hosting Experience:
  - 2009 Harlem Globetrotters
  - 2008 World Junior Championship of Hockey
  - 2007 - Present: Ontario Hockey League Mississauga St Michael's Majors
  - 1998-2007: OHL Mississauga Ice Dogs



> **COMPETITION SCHEDULE**

AUGUST								
Day	Fri	Sat	Sun	Mon	Tues	Wed	Thu	Fri
Date	7	8	9	10	11	12	13	14
Judo					•	•	•	

- Finals (may include competitions on these days)

> COMPETITION SITE PLAN

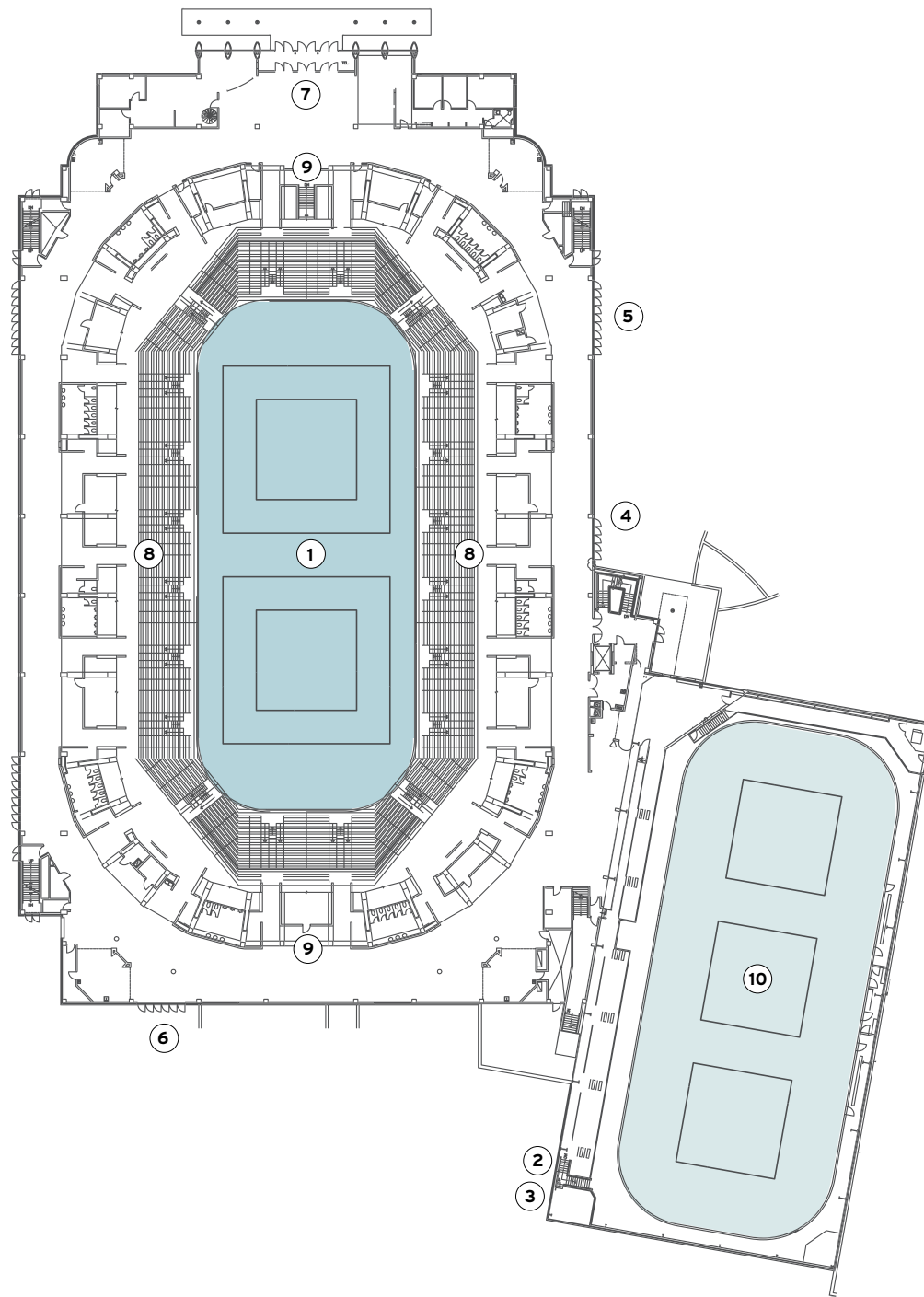

**LEGEND**

- |  |                             |
|--|-----------------------------|
| 1 COMPETITION FIELD OF PLAY                  | 7 ENTRY/EXIT FOR SPECTATORS |
| 2 ENTRY/EXIT FOR ATHLETES AND TEAM OFFICIALS | 8 SPECTATOR SEATING         |
| 3 ENTRY/EXIT FOR TECHNICAL OFFICIALS         | 9 SPECTATOR AMENITIES       |
| 4 ENTRY/EXIT FOR MEDIA                       | 10 WARM UP AREA             |
| 5 ENTRY/EXIT FOR SPONSORS                    |                             |
| 6 ENTRY/EXIT FOR STAFF                       |                             |

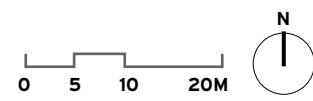



## SPORT: POWERLIFTING

### VENUE: Variety Village

Variety Village is a specialized fitness and life skills facility designed to assist people of all abilities develop independence, self-confidence and a feeling of belonging. Variety Village also provides a high-performance training venue for some of Ontario's high performance athletes with disabilities who compete at the national and international level.

This multi-purpose facility will be home to the sports of Goalball and Powerlifting, offering a wide variety of specialized equipment to assist athletes in their preparation for the Games.



### > SPORT & VENUE SPECIFICATIONS

#### CURRENT STATUS

- Existing
- Current/Future Owner: Variety, the Children's Charity

#### VENUE HIGHLIGHTS

- Meets all International Federation specifications
- Seating Capacity: 1,000
- Distance from village: 10 minutes / 12km
- Parking spaces: over 1,000

#### CURRENT AND POST GAMES USE

- Variety Village is a leading charity for young people of all abilities and their families. In its present form it includes a 15,300 m<sup>2</sup> exercise and training complex offering services to over 6,000 members.
- Hosting Experience:
  - 2008 Ontario Paraspport Summer Games
  - 2009 Canadian Junior Weighlifting Championships



### > COMPETITION SCHEDULE

AUGUST								
Day	Fri	Sat	Sun	Mon	Tues	Wed	Thu	Fri
Date	7	8	9	10	11	12	13	14
Powerlifting	•	•	•					

- Finals (may include competitions on these days)

> COMPETITION SITE PLAN

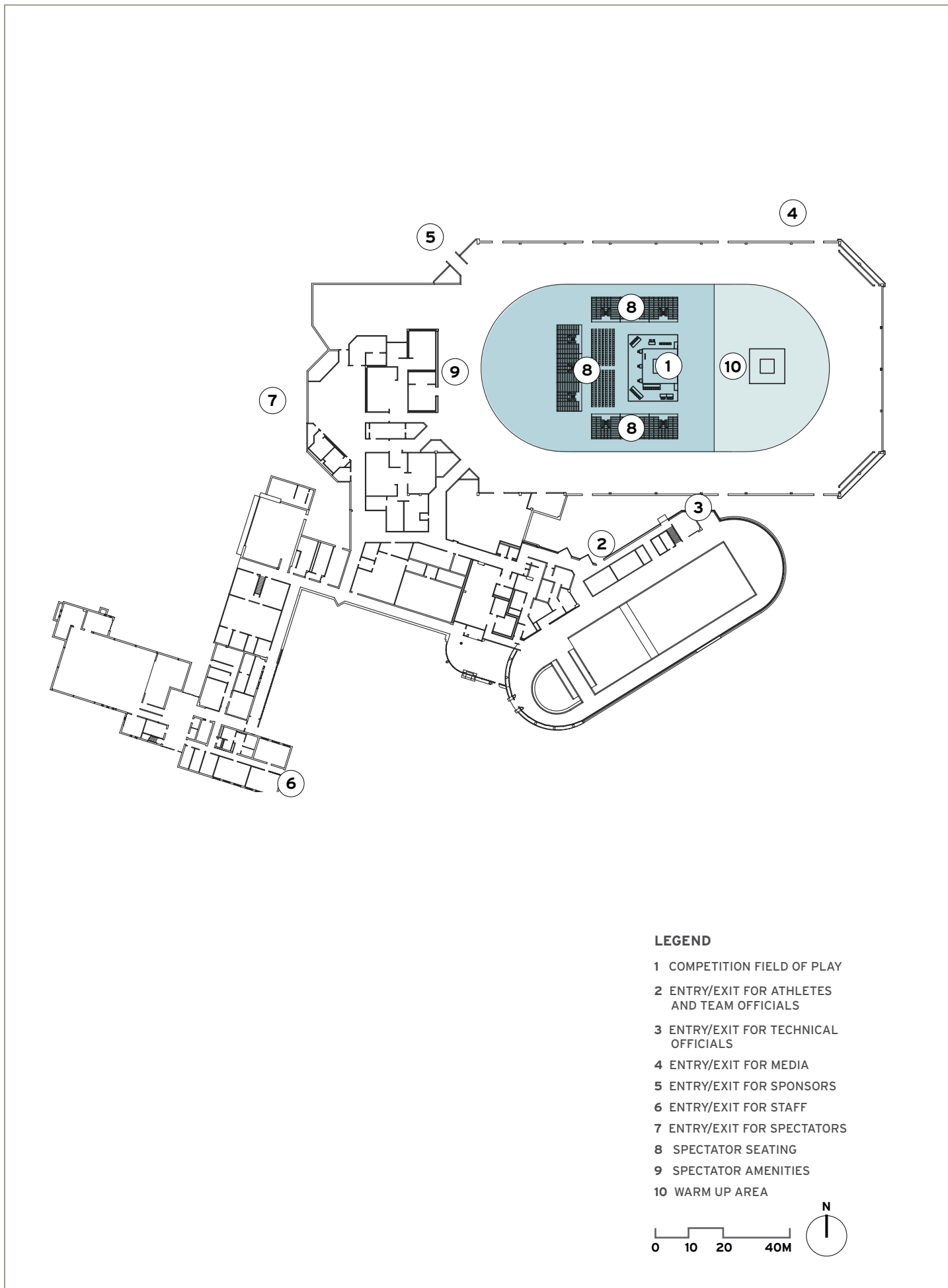

**LEGEND**

- 1 COMPETITION FIELD OF PLAY
- 2 ENTRY/EXIT FOR ATHLETES AND TEAM OFFICIALS
- 3 ENTRY/EXIT FOR TECHNICAL OFFICIALS
- 4 ENTRY/EXIT FOR MEDIA
- 5 ENTRY/EXIT FOR SPONSORS
- 6 ENTRY/EXIT FOR STAFF
- 7 ENTRY/EXIT FOR SPECTATORS
- 8 SPECTATOR SEATING
- 9 SPECTATOR AMENITIES
- 10 WARM UP AREA

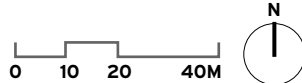



**SPORT:**  
**SWIMMING**

**VENUE:** Pan American Aquatics Centre

The Pan American Aquatics Centre will be one of the most significant new developments of the 2015 Games.

This state of the art facility will include the amenities required for both international competition and training, and include dedicated areas for all indoor aquatics sports with a dedicated dive tank and two 10 lane, 50m pools.

The CSIO is a collaborative project between the University, the City of Toronto and the 2015 Games, which combines the needs of a major event, Canada's largest university, and Canada's largest city.

> **SPORT & VENUE SPECIFICATIONS**

CURRENT STATUS
<ul style="list-style-type: none"> <li>• New Build</li> <li>• Construction Status: Completed by 2014</li> <li>• Current/Future owner: City of Toronto/University of Toronto</li> </ul>
VENUE HIGHLIGHTS
<ul style="list-style-type: none"> <li>• Meets all International Federation specifications</li> <li>• Seating Capacity: 10,000</li> <li>• Distance from village: 22 minutes/ 29km</li> <li>• Parking spaces: over 3,000</li> </ul>
CURRENT AND POST GAMES USE
<ul style="list-style-type: none"> <li>• The facility will link together community sport and recreation use, competitive use by university and sports clubs, a national training centre for Canada's top athletes and provide a venue to host the world for major national and international competitions.</li> </ul>



> **COMPETITION SCHEDULE**

AUGUST								
Day	Fri	Sat	Sun	Mon	Tues	Wed	Thu	Fri
Date	7	8	9	10	11	12	13	14
Swimming		●	●	●	●	●	●	

● Finals (may include competitions on these days)

> COMPETITION SITE PLAN

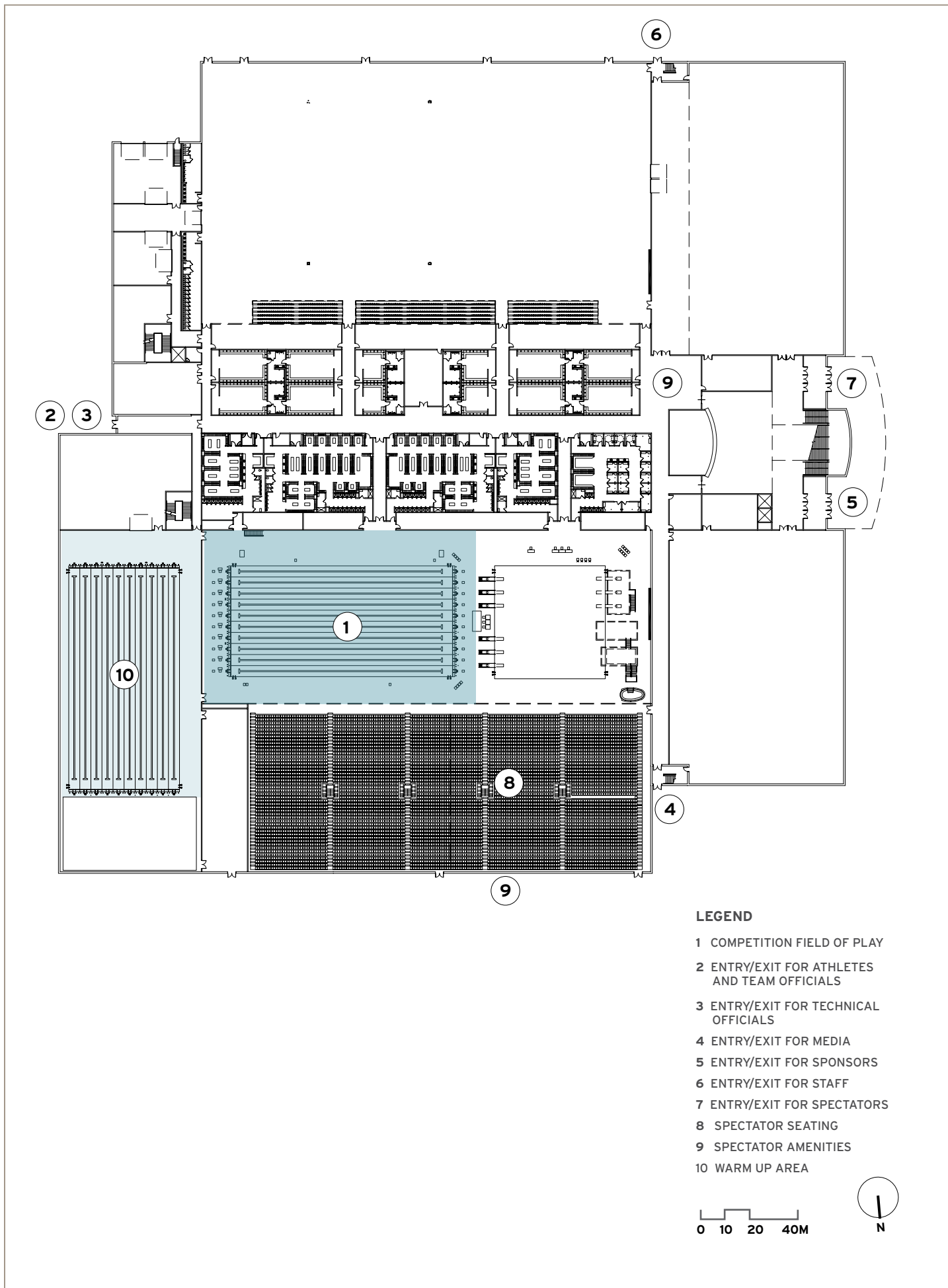

**LEGEND**

- 1 COMPETITION FIELD OF PLAY
- 2 ENTRY/EXIT FOR ATHLETES AND TEAM OFFICIALS
- 3 ENTRY/EXIT FOR TECHNICAL OFFICIALS
- 4 ENTRY/EXIT FOR MEDIA
- 5 ENTRY/EXIT FOR SPONSORS
- 6 ENTRY/EXIT FOR STAFF
- 7 ENTRY/EXIT FOR SPECTATORS
- 8 SPECTATOR SEATING
- 9 SPECTATOR AMENITIES
- 10 WARM UP AREA

0 10 20 40M

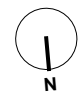



**SPORT:**  
**TABLE TENNIS**

**VENUE: Centennial Community Centre**

This facility offers a multi-sport environment for sport and recreation users looking to get active and participate in sport. In addition to the arena, the facility has a 25 metre pool, fitness centre and meeting rooms.

With the 2,500 seat main arena hosting the table tennis competition and the adjacent area housing the required warm-up and training area, this venue will provide a compact setting for the fast-paced action of this racquet sport.

> **SPORT & VENUE SPECIFICATIONS**

CURRENT STATUS
<ul style="list-style-type: none"> <li>Existing</li> <li>Built 1972, renovated 1999</li> <li>Current/Future Owner: City of Markham</li> </ul>
VENUE HIGHLIGHTS
<ul style="list-style-type: none"> <li>Meets all International Federation specifications</li> <li>Seating Capacity: 2,500</li> <li>Distance from village: 27minutes / 29Km</li> <li>Parking spaces: over 1000</li> </ul>
CURRENT AND POST GAMES USE
<ul style="list-style-type: none"> <li>The facility will continue to serve the residents and athletes in the area seeking enhanced sport and recreation opportunities.</li> </ul>



> **COMPETITION SCHEDULE**

AUGUST								
Day	Fri	Sat	Sun	Mon	Tues	Wed	Thu	Fri
Date	7	8	9	10	11	12	13	14
Table Tennis		●	●	●	●	●	●	

● Competition    ● Finals (may include competitions on these days)

> COMPETITION SITE PLAN

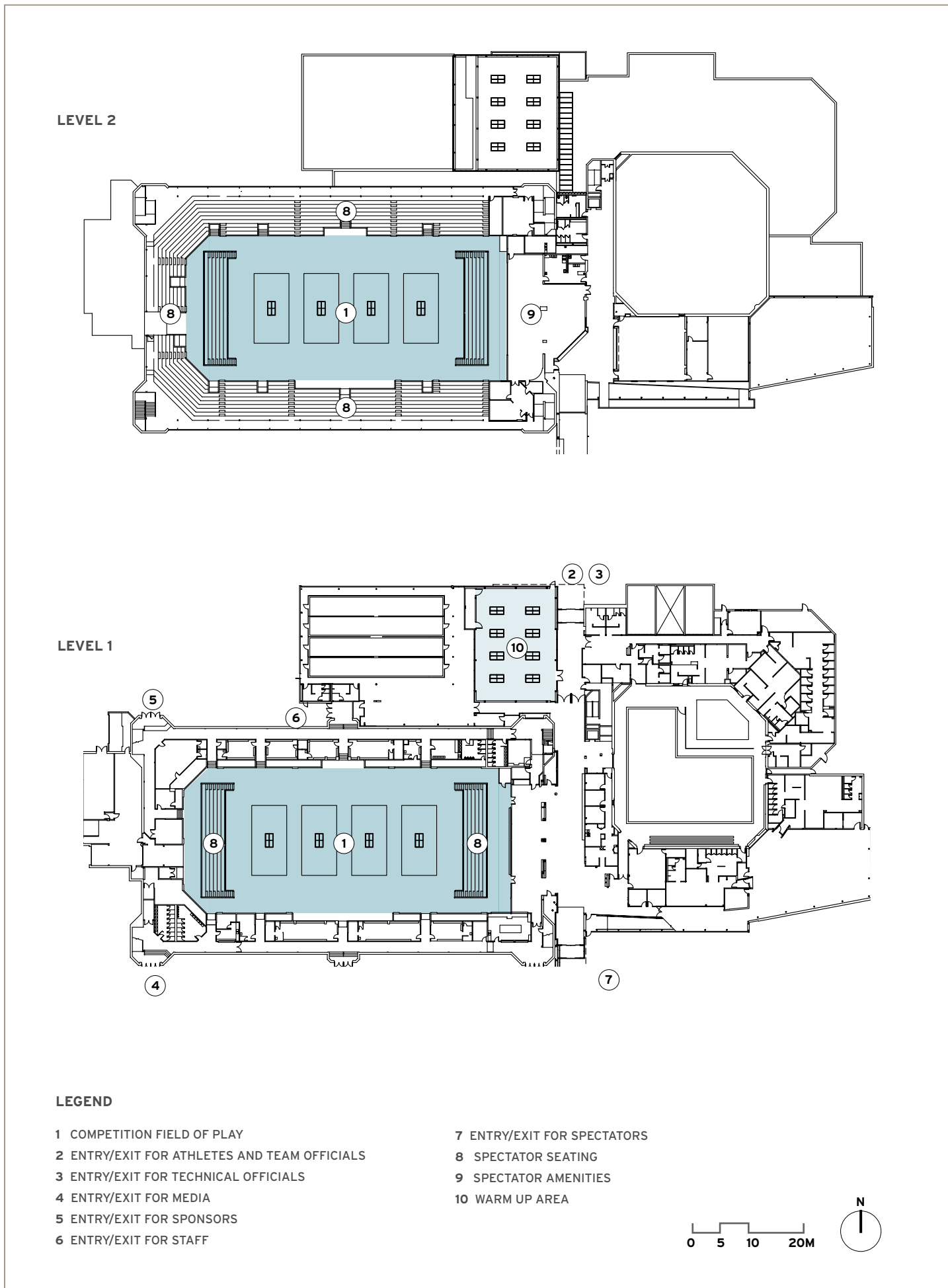



**SPORT:**  
**VOLLEYBALL**  
**SITTING**

**VENUE: Canadian Sport Institute Ontario**

The Canadian Sport Institute Ontario (CSIO) will be part of a 28,000 m2 facility that will include a significant multi-sport field house, the Pan American Aquatics Centre, and will house the latest technology to support Canada's participation in high performance summer sports.

Parapan Volleyball will be held in the fieldhouse component of the CSIO, providing athletes with a leading edge competitive venue and access to the flagship facility of the 2015 Games.

The CSIO is a collaborative project between the University, the City of Toronto and the 2015 Games, which combines the needs of a major event, Canada's largest university, and Canada's largest city.

**> SPORT & VENUE SPECIFICATIONS**

CURRENT STATUS
<ul style="list-style-type: none"> <li>• New build</li> <li>• Construction Status: Completed by 2014</li> <li>• Current/Future owner: City of Toronto/University of Toronto</li> </ul>
VENUE HIGHLIGHTS
<ul style="list-style-type: none"> <li>• Meets all International Federation specifications</li> <li>• Seating Capacity: 3,000</li> <li>• Distance from village: 22 minutes / 29km</li> <li>• Parking spaces: over 3,000</li> </ul>
CURRENT AND POST GAMES USE
<ul style="list-style-type: none"> <li>• The facility will link together community sport and recreation use, competitive use by university and sports clubs, a national training centre for Canada's top athletes and provide a venue to host the world for major national and international competitions.</li> </ul>



**> COMPETITION SCHEDULE**

AUGUST								
Day	Fri	Sat	Sun	Mon	Tues	Wed	Thu	Fri
Date	7	8	9	10	11	12	13	14
Volleyball Sitting		●	●	●	●	●	●	●

● Competition    ● Finals (may include competitions on these days)

> COMPETITION SITE PLAN

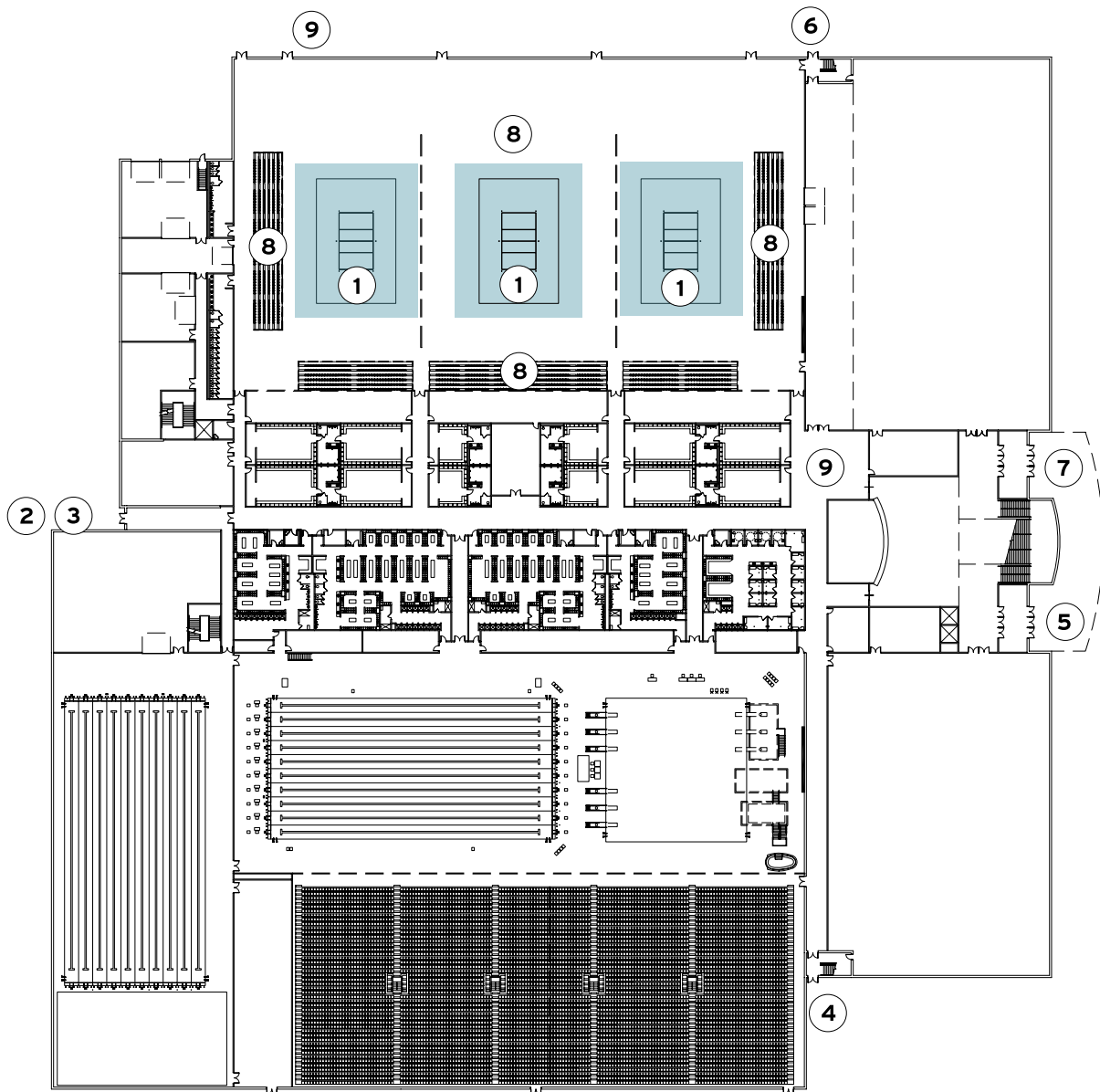

LEGEND

- |  |                             |
|--|-----------------------------|
| 1 COMPETITION FIELD OF PLAY                  | 7 ENTRY/EXIT FOR SPECTATORS |
| 2 ENTRY/EXIT FOR ATHLETES AND TEAM OFFICIALS | 8 SPECTATOR SEATING         |
| 3 ENTRY/EXIT FOR TECHNICAL OFFICIALS         | 9 SPECTATOR AMENITIES       |
| 4 ENTRY/EXIT FOR MEDIA                       |                             |
| 5 ENTRY/EXIT FOR SPONSORS                    |                             |
| 6 ENTRY/EXIT FOR STAFF                       |                             |

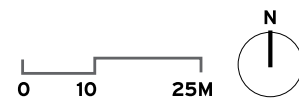



**SPORT:**  
**WHEELCHAIR  
BASKETBALL**

**VENUE: Abilities Centre**

The Abilities Centre is a new fully accessible facility that will be built adjacent to Iroquois Sports Park, a municipally owned and operated sport and recreation facility housing six arenas, two swimming pools, sports fields, and tennis courts.

The facility, specifically designed to provide a dynamic and comprehensive range of services to an unparalleled number of people with disabilities, will be home to the Wheelchair Basketball competition providing athletes with a world-class centre of excellence for adaptive and inclusive sport and recreation.

The site will also house the Parapan Tennis event creating a Parapan cluster of sports for athletes and spectators to enjoy.

**> SPORT & VENUE SPECIFICATIONS**

CURRENT STATUS
<ul style="list-style-type: none"> <li>• New Build</li> <li>• Construction Status: Completed by 2014</li> <li>• Current / Future Owner: Abilities Centre</li> </ul>
VENUE HIGHLIGHTS
<ul style="list-style-type: none"> <li>• Meets all International Federation specifications</li> <li>• Seating Capacity: 3,000</li> <li>• Distance from village: 40 minutes / 52km</li> <li>• Parking spaces: over 1,000</li> </ul>
CURRENT AND POST GAMES USE
<ul style="list-style-type: none"> <li>• The Abilities Centre will provide barrier-free athletic and performing arts facilities for people of all ages with a special emphasis on programming and accessibility for people with disabilities. The facility will contain a 12,000 m<sup>2</sup> multi-purpose gymnasium.</li> </ul>



**> COMPETITION SCHEDULE**

AUGUST								
Day	Fri	Sat	Sun	Mon	Tues	Wed	Thu	Fri
Date	7	8	9	10	11	12	13	14
Wheelchair Basketball		●	●	●	●	●	●	

● Competition    ● Finals (may include competitions on these days)

> COMPETITION SITE PLAN

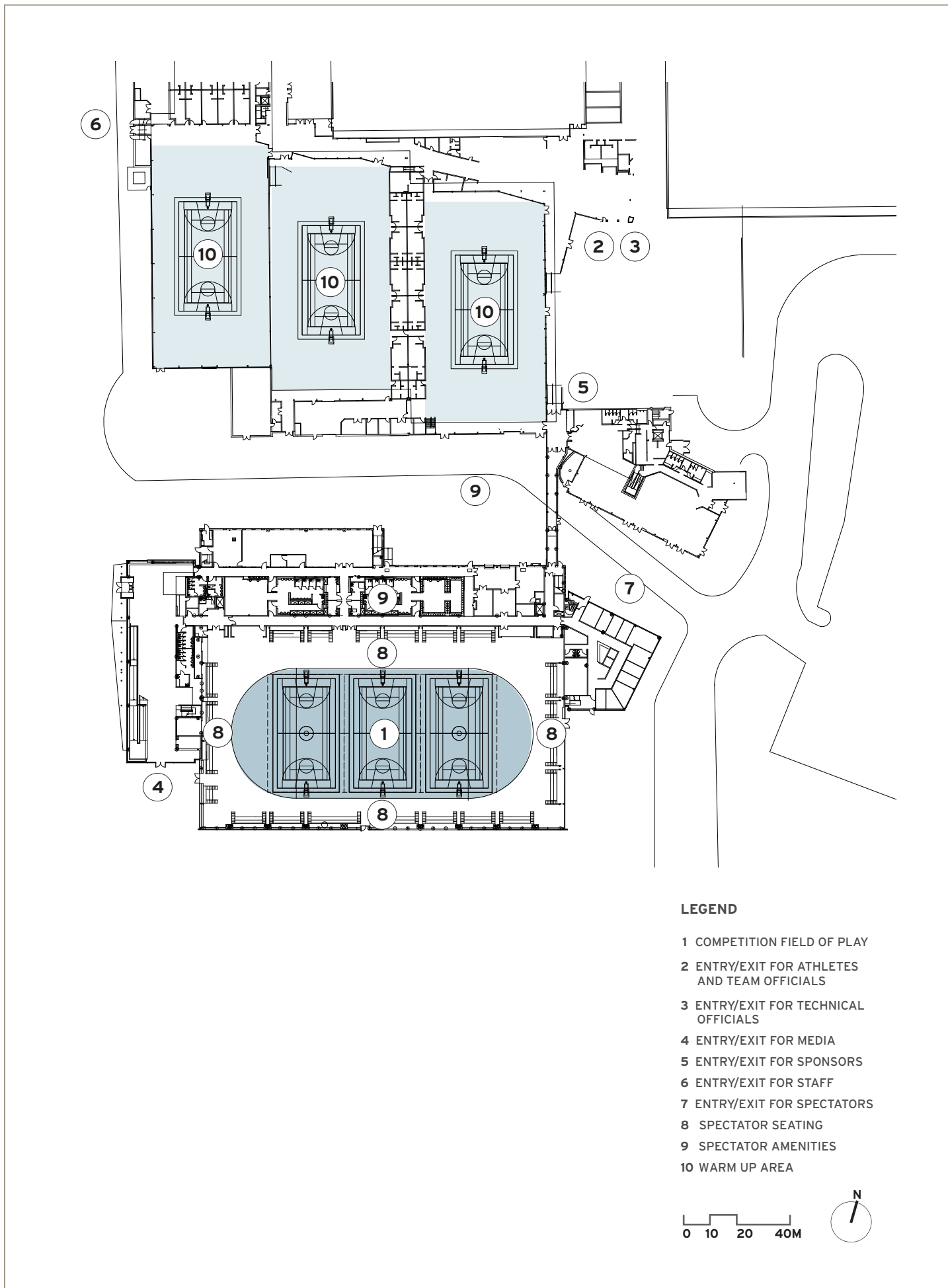

**LEGEND**

- 1 COMPETITION FIELD OF PLAY
- 2 ENTRY/EXIT FOR ATHLETES AND TEAM OFFICIALS
- 3 ENTRY/EXIT FOR TECHNICAL OFFICIALS
- 4 ENTRY/EXIT FOR MEDIA
- 5 ENTRY/EXIT FOR SPONSORS
- 6 ENTRY/EXIT FOR STAFF
- 7 ENTRY/EXIT FOR SPECTATORS
- 8 SPECTATOR SEATING
- 9 SPECTATOR AMENITIES
- 10 WARM UP AREA

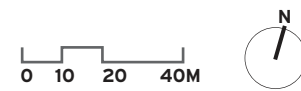



**SPORT:**  
**WHEELCHAIR TENNIS**

**VENUE:** Iroquois Sports Park

Built adjacent to the Abilities Centre, the Iroquois Sports Park is a large municipally owned and operated sport and recreation facility housing 6 arenas, 2 swimming pools, sports fields, and tennis courts.

The tennis competition will have the benefit of the amenities located in the Abilities Centre, which will be a world-class centre of excellence for adaptive and inclusive sport and recreation.

The site will also house the Parapan Wheelchair Basketball event creating a Parapan cluster of sports for athletes and spectators to enjoy.

> **SPORT & VENUE SPECIFICATIONS**

CURRENT STATUS
<ul style="list-style-type: none"> <li>Existing</li> <li>Built in 1997</li> <li>Current/Future Owner: Town of Whitby</li> </ul>
VENUE HIGHLIGHTS
<ul style="list-style-type: none"> <li>Meets all International Federation specifications</li> <li>Seating Capacity: 2,000</li> <li>Distance from village: 40 minutes / 52km</li> <li>Parking spaces: over 1,000</li> </ul>
CURRENT AND POST GAMES USE
<ul style="list-style-type: none"> <li>Iroquois Sports Park is a 25,000 m<sup>2</sup>, multi-purpose sport and recreation facility providing area residents with access to a compact distribution of venues to support their physical activity and sport participation objectives.</li> </ul>



> **COMPETITION SCHEDULE**

AUGUST								
Day	Fri	Sat	Sun	Mon	Tues	Wed	Thu	Fri
Date	7	8	9	10	11	12	13	14
Wheelchair Tennis		●	●	●	●	●	●	

● Competition    ● Finals (may include competitions on these days)

> COMPETITION SITE PLAN

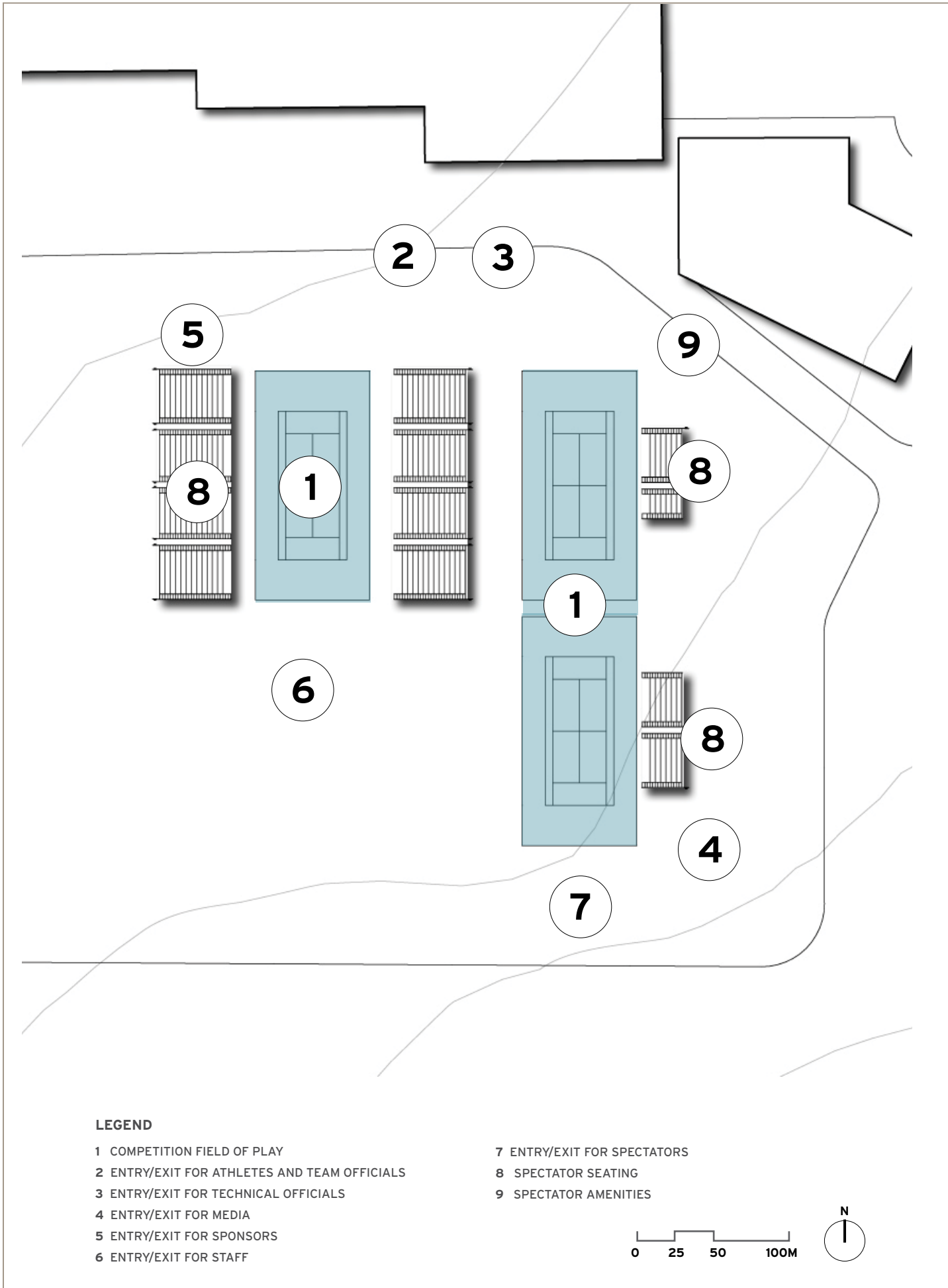



## OUR ENVIRONMENTAL COMMITMENT

Toronto is proud to be a green city. Your Toronto 2015 bid book was produced using environmentally sustainable means to minimize its ecological footprint.

### PAPER:

Pages of this book were printed on UTOPIA TWO:XTRA GREEN (U2:XG) 80 lb Dull Text. U2:XG is an FSC-certified paper manufactured with electricity in the form of renewable energy (wind, hydro, and biogas), and includes a minimum of 30% post-consumer recovered fiber.

### PRINTING:

Practices include: green chemistry principles, recycling of all residual materials, and capturing of volatile organic compounds (VOCs) from pressroom operations.

### ENVIRONMENTAL CALCULATOR:

Using 1,320 lb. of 80lb Utopia U2 XG text (30% PCW) of virgin fibers paper reduces your ecological footprint of :

Tree(s) : 3

Solid waste : 214 lb

Water : 2,019 gal

Suspended particles in the water : 1.4 lb

Air emissions : 597 lb

Natural gas : 1,632 ft<sup>3</sup>

